

# MODEL 1500 CONSERVATION CULTIVATOR OPERATOR & PARTS MANUAL

**M0150**

**Rev. 4/98**

This manual is applicable to:    Model: 1500  
   Serial Number: 800000 and on

Record the model number and serial number of your cultivator with date purchased:

Model Number \_\_\_\_\_ 1500 \_\_\_\_\_

Serial Number \_\_\_\_\_

Date Purchased \_\_\_\_\_

## SERIAL NUMBER

The serial number plate is located on the cultivator toolbar to be readily available. It is suggested that the serial number and purchase date be recorded above.

The serial number provides important information about your cultivator and may be required to obtain the correct replacement part. Always provide the serial number and model number to your KINZE® Dealer when ordering parts or anytime correspondence is made with KINZE Manufacturing, Inc.

05209826



**Rigid Frame Machine**

70691-13a



**Hydraulic Fold Machine**

*KINZE® is a registered trademark of KINZE Manufacturing, Inc.  
The John Blue® trademark is owned by the John Blue Company.*

Rev. 4/98



# PREDELIVERY/DELIVERY CHECK LIST

## TO THE DEALER

Predelivery service includes assembly, lubrication, adjustment and test. This service helps to ensure that the cultivator will be delivered to the customer ready for field use.

## PREDELIVERY CHECK LIST

After the cultivator has been completely assembled, use the following check list and inspect the cultivator. Check off each item as it is found satisfactory or after proper adjustment is made.

- Recheck to be sure row units and optional attachments are properly spaced and assembled.
- Be sure all grease fittings are in place and lubricated.
- Check cultivator and make sure all working parts are moving freely, bolts are tight and cotter pins are spread.
- Check all drive chains (If Applicable) for proper tension and alignment.
- Inflate tire to specified PSI air pressure. Tighten wheel bolts to specified torque. (If Applicable)
- Check to be sure all safety decals are correctly located and legible. Replace if damaged.
- Check to be sure the red reflectors and amber reflectors are correctly located and visible when the cultivator is in transport position.
- Check to be sure SMV sign is in place.
- Check to be sure safety/warning lights are installed correctly and working properly.
- (Folding Models Only) Raise wings half way up and drop back to level to be sure lift cylinders are charged.
- (Folding Models Only) Check to be sure wing stops are located and adjusted correctly. See "Operation Section".
- Paint all parts scratched in shipment or assembly.
- Be sure all safety lockup devices are on the cultivator and correctly located.

***This cultivator has been thoroughly checked and to the best of my knowledge is ready for delivery to the customer.***

---

(Signature Of Set-Up Person/Dealer Name/Date)

## OWNER REGISTER

Name \_\_\_\_\_

Date Sold \_\_\_\_\_

Street Address \_\_\_\_\_

Model \_\_\_\_\_

City, State/Province & ZIP \_\_\_\_\_

Serial Number \_\_\_\_\_

Dealer Name \_\_\_\_\_

Dealer Number \_\_\_\_\_

## DELIVERY CHECK LIST

At the time the cultivator is delivered, the following check list is a reminder of very important information which should be conveyed to the customer. Check off each item as it is fully explained to the customer.

- Advise the customer that the life expectancy of this or any other machine is dependent on regular lubrication as directed in the Operator & Parts Manual.
- Tell the customer about all safety precautions.
- Along with the customer, check to be sure the red reflectors, amber reflectors and SMV sign are clearly visible with the cultivator in transport position and attached to the tractor. Check to be sure flashing warning lights are in working condition. Tell the customer to check federal, state/provincial and local regulations before towing or transporting on a road or highway.
- Give the Operator & Parts Manual to the customer and explain all operating adjustments.
- Read warranty to customer.
- Complete Warranty And Delivery Report form.

***To the best of my knowledge this machine has been delivered ready for field use and customer has been fully informed as to proper care and operation.***

---

(Signature Of Delivery Person/Dealer Name/Date)

## AFTER DELIVERY CHECK LIST

The following is a list of items we suggest to check during the first season of use of the equipment.

- Check with the customer as to the performance of the cultivator.
- Review with the customer the importance of proper maintenance and adherence with all safety precautions.
- Check for parts that may need to be adjusted or replaced.
- Check to be sure all safety decals, SMV sign and reflectors are correctly located and legible. Replace if damaged or missing.
- Check to be sure safety/warning lights are working properly.

---

(Signature Of Follow-Up Person/Dealer Name/Date)

**RETURN THIS COMPLETED FORM TO KINZE® IMMEDIATELY, along with Warranty And Delivery Report.  
Retain photocopy of this form at dealership for After Delivery Check.**

Tear Along Perforation

# TABLE OF CONTENTS

---

<b>TO THE OWNER</b> .....	<b>1-1</b>
<b>WARRANTY</b> .....	<b>1-2</b>
<b>INTRODUCTION</b> .....	<b>2-1</b>
<b>SPECIFICATIONS</b> .....	<b>3-1</b>
<b>SAFETY PRECAUTIONS</b> .....	<b>4-1</b>
<b>SAFETY WARNING SIGNS</b> .....	<b>5-1</b>
<b>OPERATION</b>	
Checking Application Rates .....	6-14
Coil Anhydrous Shank Attachment .....	6-17
Coulter Blade Adjustment .....	6-7
Cut-Away Weeding Discs Attachment .....	6-11
Double Edge Shares .....	6-4
Down-Force Spring Adjustment .....	6-5
Dual Lift Assist Wheels Attachment .....	6-17
Field Test .....	6-8
Flow Control Valve Adjustment .....	6-17
Initial Preparation Of The Cultivator .....	6-1
Leveling The Cultivator .....	6-5
Liquid Fertilizer Application Attachment .....	6-13
Liquid Fertilizer Application Rates .....	6-15
Metric Conversion Table .....	6-8
Operating Depth Adjustment .....	6-6
Operating Speed .....	6-7
Parking Stand Adjustment .....	6-4
Rear Telescoping Hitch Attachment .....	6-16
Ridging Attachment .....	6-11
Rock Shaft Depth Control .....	6-4
Rotary Hoe/Rolling Disc Crop Shield With Mounting Support Attachment .....	6-12
Scraper Adjustment .....	6-7
Shank Trip .....	6-7
Tire Pressure .....	6-7
Tractor Preparation And Hookup .....	6-1
Tractor Requirements .....	6-1
Transporting The Cultivator .....	6-7
Troubleshooting .....	6-9
<b>LUBRICATION</b>	
Bushings .....	7-1
Grease Fittings .....	7-2
Liquid Fertilizer Drive Chain .....	7-2
Lubrication Symbols .....	7-1
Sealed Bearings .....	7-1
Wheel Bearings (Dual Lift Assist/Liquid Fertilizer Drive) .....	7-2
<b>MAINTENANCE</b>	
Bushings .....	8-1
Flow Control Valve Inspection .....	8-4
Liquid Fertilizer Chain Tension Adjustment .....	8-2
Liquid Fertilizer Piston Pump/Flow Divider .....	8-4
Mounting Bolts And Hardware .....	8-1
Piston Pump Storage .....	8-4
Piston Pump Troubleshooting .....	8-4
Preparation For Storage .....	8-3
Row Unit Coulter .....	8-2
Shank Point .....	8-2
Wheel Bearing Lubrication Or Replacement (Dual Lift Assist/Liquid Fertilizer Drive) .....	8-2
Wing Fold Cylinder .....	8-3
Wiring Diagram .....	8-3

# TABLE OF CONTENTS

---

## ASSEMBLY

Contents Listings .....	9-23
Machine Assembly .....	9-1
Attachment - Coil Anhydrous Shank With Knife Mount .....	9-21
Attachment - Cut-Away Weeding Discs .....	9-4
Attachment - Dual Lift Assist Wheel Package .....	9-19
Attachment - Liquid Fertilizer Application Equipment .....	9-7
Attachment - Rear Telescoping Hitch And 6" Hitch Extension .....	9-22
Attachment - Ridging Attachment .....	9-5
Attachment - Rotary Hoe/Rolling Disc Crop Shield With Mounting Support .....	9-5
<b>PARTS LIST INDEX .....</b>	<b>P1</b>
<b>PARTS SECTION NUMERICAL INDEX .....</b>	<b>a</b>

# TO THE OWNER

---

KINZE Manufacturing, Inc. would like to thank you for your patronage. We appreciate your confidence in KINZE® farm machinery. Your KINZE® cultivator has been carefully designed and sturdily built to provide dependable operation in return for your investment.

**This manual has been prepared to aid you in the operation and maintenance of the cultivator. It should be considered a permanent part of the machine and remain with the machine when you sell it.**

It is the responsibility of the user to read and understand the Operator & Parts Manual in regards to safety, operation, lubrication and maintenance before operation of this equipment. It is the user's responsibility to inspect and service the machine routinely as directed in the Operator & Parts Manual. We have attempted to cover all areas of safety, operation, lubrication and maintenance; however, there may be times when special care must be taken to fit your conditions.

Throughout this manual the symbol  and the words **NOTE**, **CAUTION**, **WARNING** and **DANGER** are used to call your attention to important safety information. The definition of each of these terms used follows:

**NOTE:** Indicates a special point of information.

**CAUTION:** Indicates that a failure to observe can cause damage to the machine or equipment.



**WARNING:** Indicates that a failure to observe can cause damage to the machine or equipment and/or personal injury.



**DANGER:** Indicates that a failure to observe can cause most serious damage to the machine or equipment and/or most serious personal injury.



**WARNING:** Some photos in this manual may show safety covers, shields or lockups removed for visual clarity. **NEVER OPERATE** the machine without all safety covers, shields and lockups in place.

**NOTE:** Some photos in this manual may have been taken of prototype machines. Production machines may vary in appearance.

**NOTE:** Some photos and illustrations in this manual show optional attachments installed. Contact your KINZE® Dealer for purchase of optional attachments.

# WARRANTY

---

The KINZE® Limited Warranty for your new machine is stated on the back of the retail purchaser's copy of the Warranty And Delivery Report form.

Warranty, within the warranty period, is provided as part of KINZE's support program for registered KINZE® products which have been operated and maintained as described in this manual. Evidence of equipment abuse or modification beyond original factory specifications will void the warranty. Normal maintenance, service and repair is not covered by KINZE® warranty.

To register your KINZE® product for warranty, a Warranty And Delivery Report form must be completed by the KINZE® Dealer and signed by the retail purchaser, with copies to the Dealer, to the retail purchaser and to KINZE Manufacturing, Inc. Registration must be completed and sent to KINZE Manufacturing, Inc. within 30 days of delivery of the KINZE® product to the retail purchaser. KINZE Manufacturing, Inc. reserves the right to refuse warranty on serial numbered products which have not been properly registered.

Additional copies of the Limited Warranty can be obtained through your KINZE® Dealer.

If service or replacement of failed parts which are covered by the Limited Warranty are required, it is the user's responsibility to deliver the machine along with the retail purchaser's copy of the Warranty And Delivery Report to the KINZE® Dealer for service. KINZE® warranty does not include cost of travel time, mileage, hauling or labor. Any prior arrangement made between the Dealer and the retail purchaser in which the Dealer agrees to absorb all or part of this expense should be considered a courtesy to the retail purchaser.

*KINZE® warranty does not include cost of travel time, mileage, hauling or labor.*

# INTRODUCTION

The Model 1500 Conservation Cultivator is available in various configurations and row spacings and permits installation of various attachments.

## GENERAL INFORMATION

The information used in this manual was current at the time of printing. However, due to KINZE's continual attempt to improve its product, production changes may cause your machine to appear slightly different in detail. KINZE Manufacturing, Inc. reserves the right to change specifications or design without notice and without incurring obligation to install the same on machines previously manufactured.

Right hand and left hand as used throughout this manual is determined by facing in the direction the machine will travel when in use unless otherwise stated.

63758-60a



**Rigid Frame Machine**

70691-4rev



**Hydraulic Fold Machine**  
(Shown folded for illustration purposes only.)



**WARNING: Wings must be unfolded before detaching machine from tractor.**

# INTRODUCTION

---

# SPECIFICATIONS

---

**TYPE** - Mounted - Rigid and Folding

**ROW SPACING** - 4 Row Narrow - 30" (76.2 cm) rows - 5 row units  
4 Row Wide - 36" (91.4 cm), 38" (96.5 cm) and 40" (101.6 cm) rows - 5 row units  
6 Row Narrow - 30" (76.2 cm) rows - 7 row units  
6 Row Wide - 36" (91.4 cm), 38" (96.5 cm) and 40" (101.6 cm) rows - 7 row units  
8 Row Narrow - 30" (76.2 cm) rows - 9 row units  
8 Row Wide - 36" (91.4 cm), 38" (96.5 cm) and 40" (101.6 cm) rows - 9 row units  
10 Row Narrow - 30" (76.2 cm) rows - 11 row units  
12 Row Narrow - 30" (76.2 cm) rows - 13 row units  
12 Row Wide - 36" (91.4 cm) rows - 13 row units  
12 Row Wide - 38" (96.5 cm) rows - 13 row units  
16 Row Narrow - 30" (76.2 cm) rows - 17 row units

**TOOLBAR - Rigid Frame Sizes**

4 Row Narrow 30" - 7" x 7" x 170" (17.8 cm x 17.8 cm x 431.8 cm)  
4 Row Wide 36"/38"/40" - 7" x 7" x 170" (17.8 cm x 17.8 cm x 431.8 cm)  
6 Row Narrow 30" - 7" x 7" x 190" (17.8 cm x 17.8 cm x 482.6 cm)  
6 Row Wide 36"/38"/40" - 7" x 7" x 250" (17.8 cm x 17.8 cm x 635.0 cm)  
8 Row Narrow 30" - 7" x 7" x 250" (17.8 cm x 17.8 cm x 635.0 cm)  
8 Row Wide 36"/38"/40" - 7" x 7" x 330" (17.8 cm x 17.8 cm x 838.2 cm)  
10 Row Narrow 30" - 7" x 7" x 330" (17.8 cm x 17.8 cm x 838.2 cm)

**TOOLBAR - Hydraulic Fold Sizes**

8 Row Narrow 30" - 7" x 7" x 250" (17.8 cm x 17.8 cm x 635.0 cm)  
8 Row Wide 36"/38" - 7" x 7" x 314" (17.8 cm x 17.8 cm x 797.6 cm)  
8 Row Wide 40" - 7" x 7" x 330" (17.8 cm x 17.8 cm x 838.2 cm)  
12 Row Narrow 30" - 7" x 7" x 370" (17.8 cm x 17.8 cm x 939.8 cm)  
\*12 Row Wide 36" - 7" x 7" x 442" (17.8 cm x 17.8 cm x 1122.7 cm)  
\*12 Row Wide 38" - 7" x 7" x 466" (17.8 cm x 17.8 cm x 1183.6 cm)  
\*16 Row Narrow 30" - 7" x 7" x 490" (17.8 cm x 17.8 cm x 1244.6 cm)  
\*Center section equipped with 3" x 7" (7.6 cm x 17.8 cm) forward toolbar.

**HITCH** - Category 2, 3N, 3 (4-12 Row Sizes)  
Category 3 Only (16 Row Size)

**SHANK** - Automatic spring-reset with bolt-on point. 17" (43.2 cm), 19" (48.3 cm), 21" (53.3 cm),  
25" (63.5 cm) or 27" (68.6 cm) double-edge shares (standard or hard surface)

**COULTER** - 18" (45.7 cm) solid with 4-position depth adjustment

**GAUGE WHEELS** - Two 4" x 12" (10.2 cm x 30.5 cm) chevron tread rubber tires with screw-type depth  
adjustment

**FERTILIZER TUBE** - 1/2" (13 mm) I.D. "T" welded to back and under-side of shank

**PARKING STANDS** - Two adjustable-height with 8" x 8" (20.3 cm x 20.3 cm) foot

**SMV SIGN, SAFETY/WARNING LIGHTS** - Standard equipment

# SPECIFICATIONS

## BASE MACHINE

<b>RIGID FRAME SIZES</b>	4 Row N	4 Row W	6 Row N	6 Row W	8 Row N	8 Row W	10 Row N
Transport Width	14' 2" (431.8 cm)	14' 2" (431.8 cm)	15' 10" (482.6 cm)	20' 10" (635.0 cm)	20' 10" (635.0 cm)	27' 6" (838.2 cm)	27' 6" (838.2 cm)
Operating Length - Center Of Hitch Pin To Tip Of Share Mount	4' 0" (121.9 cm)	4' 0" (121.9 cm)	4' 0" (121.9 cm)	4' 0" (121.9 cm)	4' 0" (121.9 cm)	4' 0" (121.9 cm)	4' 0" (121.9 cm)
Weight	2179 lbs. (987 kg)	2179 lbs. (987 kg)	3005 lbs. (1361 kg)	3189 lbs. (1445 kg)	3810 lbs. (1726 kg)	4055 lbs. (1837 kg)	4696 lbs. (2127 kg)
<b>HYDRAULIC FOLD SIZES</b>	8 Row N	8 Row 36/38	8 Row 40	12 Row N	12 Row 36	12 Row 38	16 Row N
Transport Width	13' 1" (398.8 cm)	15' 8" (477.5 cm)	16' 4" (497.8 cm)	18' 1" (551.2 cm)	21' 7" (657.9 cm)	22' 0" (670.6 cm)	23' 1" (703.6 cm)
Operating Length - Center Of Hitch Pin To Tip Of Share Mount	4' 0" (121.9 cm)	4' 0" (121.9 cm)	4' 0" (121.9 cm)	4' 0" (121.9 cm)	4' 4" (132.1 cm)	4' 4" (132.1 cm)	4' 4" (132.1 cm)
Weight	4399 lbs. (1993 kg)	4663 lbs. (2112 kg)	4706 lbs. (2132 kg)	5819 lbs. (2636 kg)	6321 lbs. (2863 kg)	6417 lbs. (2907 kg)	7797 lbs. (3532 kg)

## OPTIONAL ATTACHMENTS

<b>RIGID FRAME SIZES</b>	4 Row N	4 Row W	6 Row N	6 Row W	8 Row N	8 Row W	10 Row N
Cut-Away Weeding Discs	Not Recommended*	248 lbs. (113 kg)	Not Recommended*	372 lbs. (169 kg)	Not Recommended*	496 lbs. (225 kg)	Not Recommended*
Ridging Attachment	58 lbs. (26 kg)	109 lbs. (49 kg)	84 lbs. (38 kg)	156 lbs. (71 kg)	110 lbs. (50 kg)	209 lbs. (95 kg)	142 lbs. (64 kg)
Rotary Hoe Crop Shield With Mounting Support	368 lbs. (167 kg)	368 lbs. (167 kg)	552 lbs. (250 kg)	552 lbs. (250 kg)	736 lbs. (333 kg)	736 lbs. (333 kg)	920 lbs. (417 kg)
Rolling Disc Crop Shield With Mounting Support	300 lbs. (136 kg)	300 lbs. (136 kg)	450 lbs. (204 kg)	450 lbs. (204 kg)	600 lbs. (272 kg)	600 lbs. (272 kg)	750 lbs. (340 kg)
Liquid Fertilizer Application Package	470 lbs. (213 kg)	470 lbs. (213 kg)	470 lbs. (213 kg)	485 lbs. (220 kg)	485 lbs. (220 kg)	485 lbs. (220 kg)	500 lbs. (227 kg)
**Dual Lift Assist	975 lbs. (442 kg)						
***Coil Anhydrous Shank With Knife Mount	55 lbs. per shank assembly (25 kg)						
Rear Telescoping Hitch	Toolbar Mounted - 275 lbs. (125 kg) Dual Lift Assist Wheel Mounted - 340 lbs. (154 kg)						
<b>HYDRAULIC FOLD SIZES</b>	8 Row N	8 Row W	12 Row N	12 Row W	16 Row N		
Cut-Away Weeding Discs	Not Recommended*	496 lbs. (225 kg)	Not Recommended*	744 lbs. (337 kg)	Not Recommended*		
Ridging Attachment	110 lbs. (50 kg)	209 lbs. (95 kg)	168 lbs. (92 kg)	304 lbs. (138 kg)	220 lbs. (100 kg)		
Rotary Hoe Crop Shield With Mounting Support	736 lbs. (333 kg)	736 lbs. (333 kg)	1104 lbs. (500 kg)	1104 lbs. (500 kg)	1472 lbs. (667 kg)		
Rolling Disc Crop Shield With Mounting Support	600 lbs. (272 kg)	600 lbs. (272 kg)	900 lbs. (408 kg)	900 lbs. (408 kg)	1200 lbs. (544 kg)		
Liquid Fertilizer Application Package	485 lbs. (220 kg)	485 lbs. (220 kg)	500 lbs. (227 kg)	500 lbs. (227 kg)	510 lbs. (231 kg)		
** Dual Lift Assist	975 lbs. (442 kg)						
*** Coil Anhydrous Shank With Knife Mount	55 lbs. per shank assembly (25 kg)						
Rear Telescoping Hitch	Toolbar Mounted - 275 lbs. (125 kg) Dual Lift Assist Wheel Mounted - 340 lbs. (154 kg)						

\* Use not recommended for this row width

\*\* Dual lift assist wheel equipped machines require use of three point quick-hitch or guidance system three point hitch. Not compatible with toolbar mounted rear telescoping hitch. Total operating length 10' 8" (325 cm) when equipped with dual lift assist wheel option.

\*\*\* Hitch extension required when using coil anhydrous shank and toolbar mounted rear telescoping hitch.

# SAFETY PRECAUTIONS

Safe and careful operation of the tractor and cultivator at all times will contribute significantly to the prevention of accidents.

Since a large portion of accidents occur as a result of fatigue or carelessness, safety practices should be of utmost concern. Read and understand the instructions provided in this manual and on the warning signs. Review these instructions frequently! Listed below are other safety suggestions that should become common practice.

 Always make sure there are no persons near the cultivator before operating machine or tractor.

 Never allow the cultivator to be operated by anyone who is unfamiliar with the operation of all functions of the unit. All operators should read and thoroughly understand the instructions given in this manual prior to moving the unit.

 Never permit any persons other than the operator to ride on the tractor.

 Never ride on the cultivator or allow others to do so.

 Be aware of bystanders, particularly children! Always look around to make sure it is safe to start the engine of the towing vehicle or move the cultivator. This is particularly important with higher noise levels and quiet cabs, as you may not hear people shouting.

 Always wear protective clothing, substantial shoes and suitable hearing and eye sight protectors applicable for the situation.

 Wear protective gloves when handling disc blades, shares or any other parts with sharp edges.

 Serious injury or death can result from contact with electric lines. Use care to avoid contact with electric lines when moving or operating this machine.

 Do not allow anyone to get between the tractor and the cultivator while positioning for attachment or raising and lowering implement.

 Agricultural chemicals used with this unit can be dangerous. Improper selection or use can seriously injure persons, animals, plants, soil and other property. **BE SAFE:** Select the right chemical for the job. Handle it with care. Follow the instructions of the chemical manufacturer.

 Do not operate close to ditches, creeks or wash outs.

 Rim and tire servicing can be dangerous. Explosive separation of a tire and rim parts can cause serious injury or death.

 Always shut tractor engine off and shift to “park” before leaving tractor or working on cultivator.

 Never work under the cultivator while in raised position.

 Use a tractor equipped with a roll-over-protective-system and fasten your seat belt prior to starting engine.

 Always make sure flashing safety lights, SMV sign and reflectors are in place and visible prior to transporting the machine on public roads. In this regard, check federal, state/provincial and local regulations.

 Limit transport speed to 15 MPH (24 kmph). Transport only with farm tractor of sufficient size and horsepower. (See Machine Operation Section)

 Always drive at a safe speed relative to local conditions and ensure your speed is low enough for an emergency stop to be safe and secure. Keep speed to a minimum.

 Reduce speed prior to turns to avoid the risk of overturning.

# SAFETY PRECAUTIONS

---

 Reduce speed when turning and/or operating over rough terrain.

 Shift tractor into lower gear when transporting down steep hills or slopes.

 Always keep the tractor in gear to provide engine braking when going downhill. Do not coast.

 Allow for unit length when making turns.

 Avoid sudden uphill turns on steep slopes.

 Due to the height of the folding model's wings in transport, watch for obstructions such as wires, tree limbs, etc.

 Never transport folding models with lift assist wheels without quick hitch or guidance hitch. If this type of hitch is not in place a sudden stop could allow the toolbar to rotate forward causing personal injury or damage to the equipment.

 Be a safe and courteous driver. Always yield to oncoming traffic in all situations, including narrow bridges, intersections, etc.

 Always make sure there are no persons near the cultivator when cultivator wings are being lowered from transport position. (If Applicable)

 This machine has been designed and built with your safety in mind. Do not make any alterations or changes to this machine. Any alteration to the design or construction may create safety hazards.

 Before applying pressure to the hydraulic system, make sure all connections are tight and that hoses and fittings have not been damaged. Hydraulic fluid escaping under pressure can have sufficient force to penetrate skin causing injury or infection.

 The cultivator fertilizer package piston pump is designed to be **DRIVEN BY GROUND TIRES ONLY**. The use of hydraulic, electric or PTO drives may create serious safety hazards to you and the people near by. If you install such drives you must follow all appropriate safety standards and practices to protect you and others near this cultivator from injury.

 Lower the cultivator when not in use and cycle the hydraulic control lever to relieve pressure in hoses.

 If a wing lift cylinder has been removed for any reason, do not attach the rod end of the cylinder until the cylinder is cycled several times to remove any air that may be trapped in the system.

 Wings must be unfolded before detaching machine from tractor. (If Applicable)

 Store the cultivator in an area away from human activity. **DO NOT** permit children to play in or around the stored unit.

 Good maintenance is your responsibility. Poor maintenance is an invitation to trouble.

# SAFETY WARNING SIGNS

The “WARNING” signs illustrated on these pages are placed on the machine to warn of hazards. The warnings found on these signs are for your personal safety and those around you. **OBSERVE THESE WARNINGS!**

- Keep these signs clean so they can be readily observed. Wash with soap and water or cleaning solution as required.
- Replace “WARNING” signs should they become damaged, painted over or if they are missing.
- Check SMV sign periodically. Replace if it shows loss of any of its reflective property.
- When replacing decals, clean the machine surface thoroughly using soap and water or cleaning solution to remove all dirt and grease.

## Rigid Frame Machines

79630-15

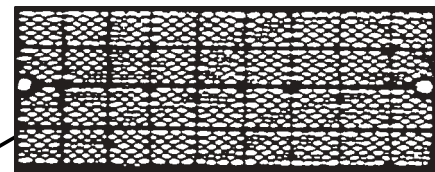
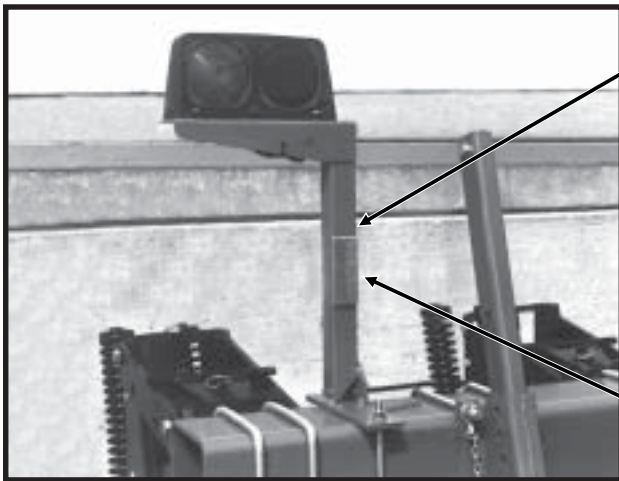

Part No. G7200-03 (Qty. 2)  
Red Reflector (Rear of Machine)

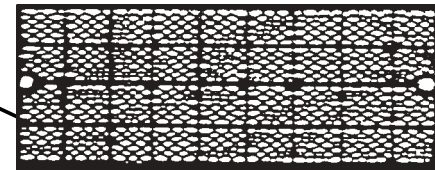

Part No. G7200-04 (Qty. 2)  
Amber Reflector (Front of Machine)

# SAFETY WARNING SIGNS

## Rigid Frame Machines

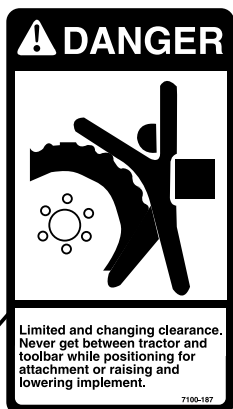

Part No. G7100-187 (Qty. 2)  
 Located on top side of toolbar on both sides of the machine.

05229818b

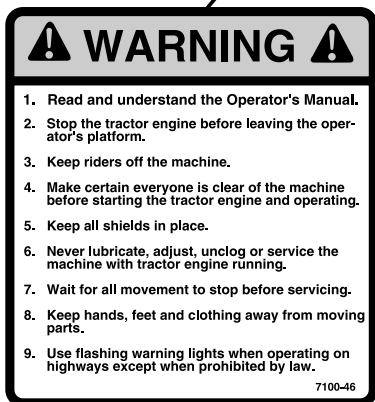
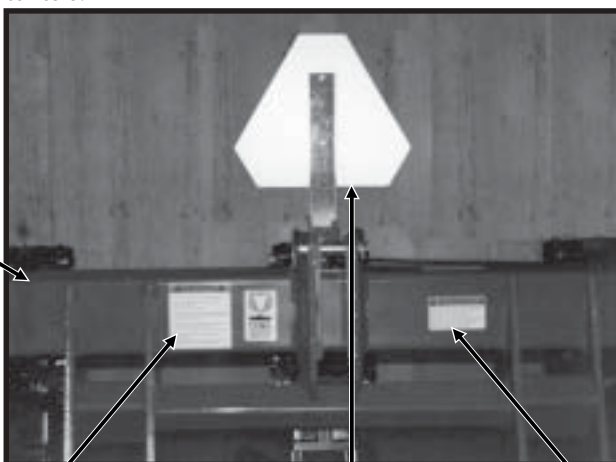

Part No. G7100-46 (Qty. 1)

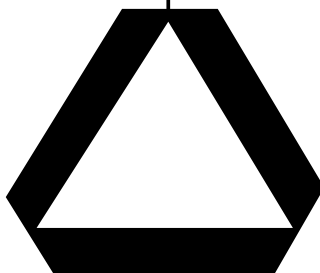

Part No. GD2199 (Qty. 1)



Part No. G7100-90 (Qty. 1)

# SAFETY WARNING SIGNS

## Hydraulic Fold Machines

79630-6

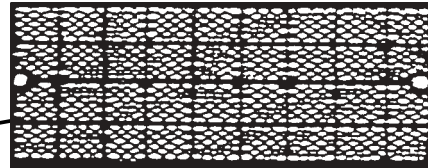

Part No. G7200-03 (Qty. 2)  
Red Reflector (Rear of Machine)

79630-3

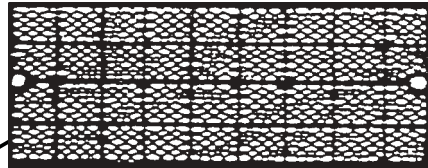
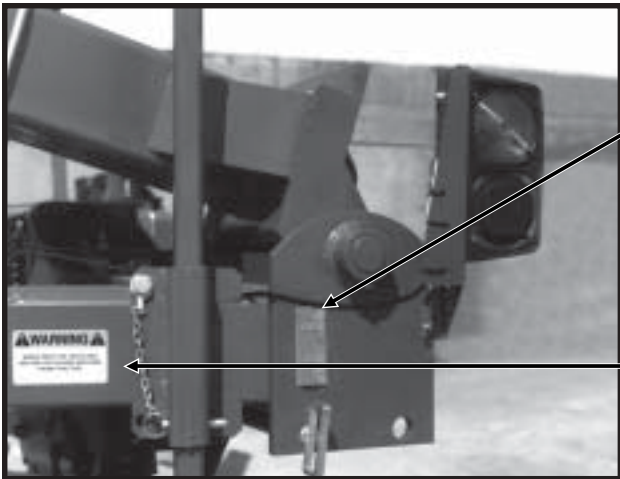

Part No. G7200-04 (Qty. 2)  
Amber Reflector (Front of Machine)



Part No. G7100-140 (Qty. 2)

# SAFETY WARNING SIGNS

## Hydraulic Fold Machines

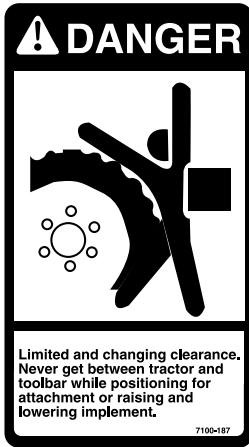

Part No. G7100-187 (Qty. 2)  
Located on both sides of machine.

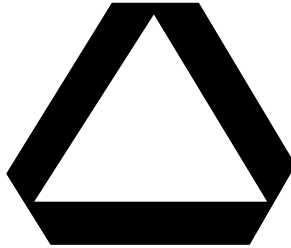

Part No. GD2199 (Qty. 1)



Part No. G7100-193 (Qty. 1)

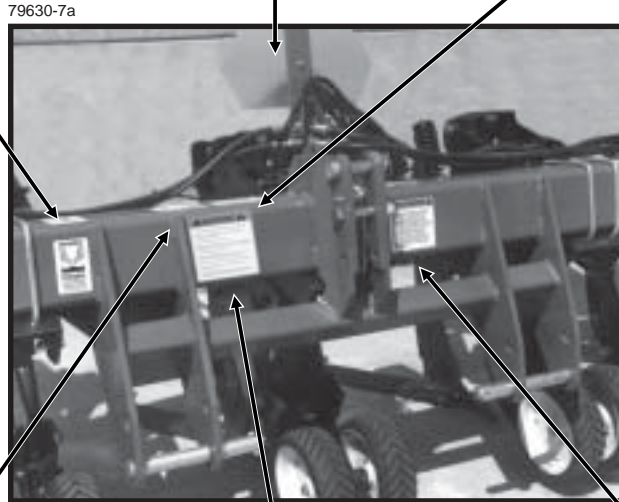

Part No. G7100-117 (Qty. 1)

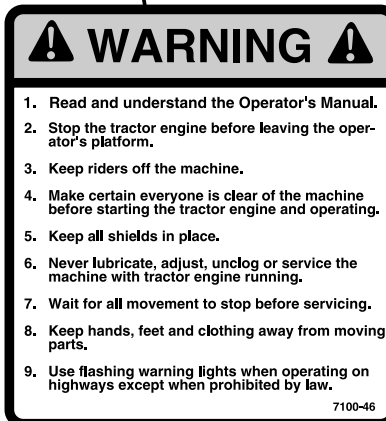

Part No. G7100-46 (Qty. 1)



Part No. G7100-90 (Qty. 1)

# OPERATION

The following information is general in nature and was written to aid the operator in preparation of the tractor and cultivator for use, and to provide general operating procedures. The operator's experience and familiarity with the machine when incorporated with the following information should combine for efficient cultivator operation and good working habits.

For your convenience, in many areas where frequent adjustment is required, the adjustment hardware has a common  $15/16$ " head for one wrench adjustment. These areas include the operating depth adjustment bolt, gauge wheel arm adjustment nut, coulter blade adjustment bolt, shank trip/reset spring adjustment bolts and optional crop shield set collar set screws.

## INITIAL PREPARATION OF THE CULTIVATOR

Lubricate the cultivator and row units per the lubrication information in this manual. Inspect mounting bolts and hardware and verify torque as recommended in the "Torque Values Chart" in the "Maintenance Section" of this manual. Make sure all tires (If Applicable) have been properly inflated. See "Tire Pressure". Check drive chain for proper tension, alignment and lubrication.

## TRACTOR REQUIREMENTS

Approximate required minimum tractor horsepower (H.P.) required for field work is listed below:

4 Row Machines - 75 H.P.    10 Row Machines - 145 H.P.  
6 Row Machines - 100 H.P.    12 Row Machines - 165 H.P.  
8 Row Machines - 125 H.P.    16 Row Machine - 180 H.P.

**NOTE: Tractor must have adequate 3 point hitch lift capacity to lift weight of machine, attachments and options. Additional horsepower may be required when using optional attachments or equipment.**



**CAUTION:** Tractor front end stability is necessary for safe efficient operation. It may be necessary to add front ballast to your tractor for satisfactory field operation, as well as adequate transport stability. Refer to your tractor operator's manual for front ballast recommendations.

All folding machines require minimum tractor hydraulic pressure of 2200-2300 PSI to fold the wings to the transport position when fully equipped with KINZE's heaviest attachments.

## TRACTOR PREPARATION AND HOOKUP

1. Set tractor rear wheel spacing to center between rows. For example: On a cultivator set for 36" (91 mm) rows, set the tractor wheel spacing at 72" (1829 mm). On wide front end tractors set front wheel spacing equal to rear wheel spacing. Check tractor operator's manual for correct front and rear tire pressure.

2. Move tractor drawbar to the side to prevent interference with center row unit.

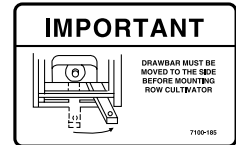

3. Both lower link arms must be the same distance off the ground so the cultivator **will lift level from side to side**. Set the sway blocks on the tractor to allow maximum side sway when cultivator is in operating position and minimum amount of side sway when in transport.

Refer to the tractor operator's manual for proper adjustment of lower links and upper link.

If a quick-attaching coupler is to be used, install onto the 3 point hitch of the tractor at this time.

The optional Dual Lift Assist Wheel Package is recommended on some sizes of folding cultivators depending on size of tractor being used with cultivator. **Dual lift assist wheel equipped machines require use of three point quick hitch or guidance system three point hitch.** When using lift assist wheels the top link pin in the cultivator hitch mast is not used.

(CLT1a)

**Top link pin NOT used**

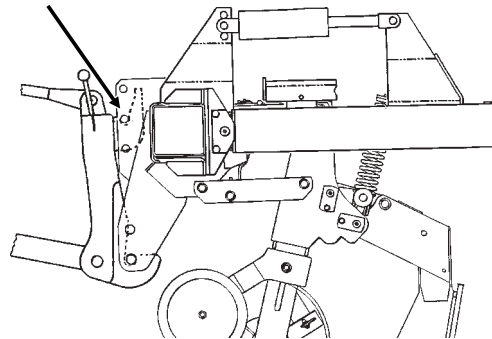

**WARNING:** Never transport machine with lift assist wheels without quick hitch. If this type of hitch is not in place, a sudden stop could allow the toolbar to rotate forward causing personal injury or damage to the equipment.

# OPERATION

4. Back tractor to cultivator and attach cultivator.



**DANGER: DO NOT ALLOW anyone to get between the tractor and cultivator while positioning for attachment or raising and lowering implement.**

05209826



The upper hitch bracket on the cultivator has three sets of holes and the lower hitch brackets have two sets of holes. Attach the tractor's lower 3 point hitch arms to the cultivator using the upper holes in the plates. The tractor lower links should be close to parallel with the ground when the cultivator is operating with the underside of the toolbar at 30" above the ground. The lower holes in the attaching plates can be used to gain additional lift height of the cultivator on tractors that have smaller rear tires such as utility type tractors.

Position lower link hitch pins as shown in the following illustrations for your type of tractor hitch. Line up holes and insert hitch pins and lock in place with hardware provided. It may be necessary to change the length of the tractor's upper link using the adjusting handle.

PFA065(CLT2)

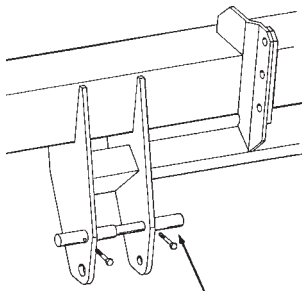

**Category 2 Bushing Position (4-12 Row)**

PFA066(CLT3)

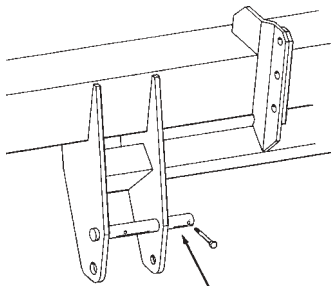

**Category 3 And 3N Bushing Position (4-12 Row)**

**NOTE: 16 row machine uses category 3 pins only.**

When using quick hitch (customer-supplied), match pin location to pin spacing in quick hitch coupler. Adjust tractor center link until the quick hitch coupler is vertical when in the operating position.

When using an automatic guidance system, refer to guidance system manual for sway block adjustment.

5. The cultivator is equipped with safety/warning lights which should be used whenever the cultivator is being transported. The connector is a 7 terminal breakaway conforming to ASAE standards. If your tractor is not equipped for safety/warning lights, consult your tractor manufacturer.

79630-14



6. Connect hydraulic hoses (If Applicable) to tractor ports in a sequence that is both familiar and comfortable to the operator.

Before attaching hoses, move tractor control levers back and forth to relieve any pressure in the tractor hydraulic system.

**IMPORTANT: Always wipe hose ends to remove any dirt before connecting couplers to tractor ports.**



**DANGER: Before applying pressure to the hydraulic system, make sure all connections are tight and that hoses and fittings have not been damaged. Hydraulic fluid escaping under pressure can have sufficient force to penetrate skin causing injury or infection.**

7. Raise cultivator slowly and watch for any interference. Check gauge wheel clearance between cultivator and rear tractor tire. Always maintain a minimum of 1" (25 mm) clearance. It may be necessary to use a quick hitch for added clearance.

**NOTE: If the tractor will not lift the cultivator high enough for transport or turning, the hitch pins may have to be placed in a lower set of holes and adjust tractors lower lift arms to the highest lift position.**

# OPERATION

When raising a machine equipped with dual lift assist wheels, the front of the cultivator should raise and then the back using the lift assist wheels to raise the rear of the cultivator. If the dual lift assist wheels are plumbed into the 3 point hitch lift circuit, adjust the flow control valve so the front of the cultivator raises before the rear of the cultivator. See "Flow Control Valve Adjustment". With cultivator lowered to operating position, adjust tractor linkage to level the toolbar. See "Leveling The Cultivator".

**With cultivator (equipped with dual lift assist wheels) raised for transport, maintain a minimum of 3" clearance between cultivator and quick hitch.**

(CLT1c)

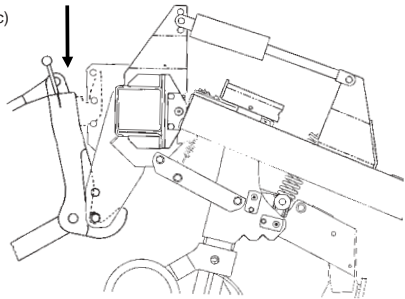

On cultivators equipped with the optional Dual Lift Assist Wheel Package, adjustment holes on the lift assist cylinder mounts allow for adjustment of lift height.

(CLT1)

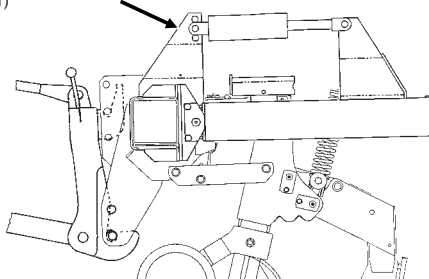

- (Folding Machines Only) Check to be sure wing stops are located and adjusted to maintain the wing fold specification as shown in the following illustration. If fold specification is not maintained, **damage could occur to the wing fold cylinder.**

**IMPORTANT:** In certain applications wing stops must be relocated to allow for installation of various options. Care must be taken to ensure that stops are adjusted up or down and located on the center toolbar so minimum fold allowance as shown is maintained.

(CLT4)

**(8 ROW 36/38 SHOWN)**  
**Minimum 30" - 8 Row**  
**Minimum 34" - 12 Row**  
**Minimum 54" - 16 Row**

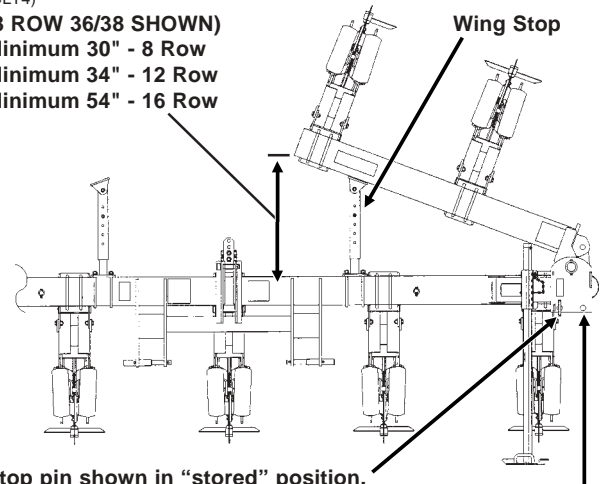

Stop pin shown in "stored" position.  
 Install stop pin in this hole during operation to lock wing rigid.

**IMPORTANT:** Raise wings half way up and drop back to level 2 or 3 times to charge oil into cylinders and bleed air so restrictor will work.

**NOTE:** Operation with the wings locked rigid is recommended. To align holes for installation of stop pins to lock the wings rigid, move the washers on the adjustment bolts in the wing hinge areas as shown below from one side of the adjustment bolt plate to the other. If float is desired on the wings, position stop pins in the "stored" position and move the washers on the adjustment bolts in the wing hinge areas to the inner side of the adjustment bolt plate to allow downward flex of the wings. The tractor must be equipped with a float valve and operated in the float position to allow the wings to float.

(CLT5)

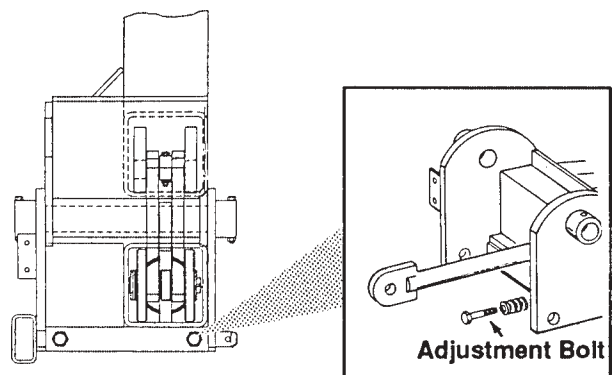

- Final adjustments (depth, spring pressure and leveling) will be required prior to field operation as applications vary.

**CAUTION:** As a general safety practice and to avoid damage to the tractor hydraulic system, always lower the cultivator when not in use.

# OPERATION

## ROCK SHAFT DEPTH CONTROL

Lower cultivator until the row unit parallel arms on the cultivator are approximately 2" (51mm) lower on the front side. Set depth stop on the tractor's rock shaft control lever. Additional field adjustment may be necessary.

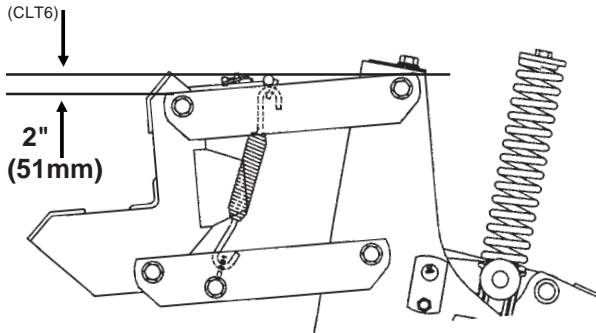

The tractor 3 point hitch draft control should be adjusted to the position setting.

Refer to the tractor operator's manual for more detailed information.

## PARKING STAND ADJUSTMENT

05229817

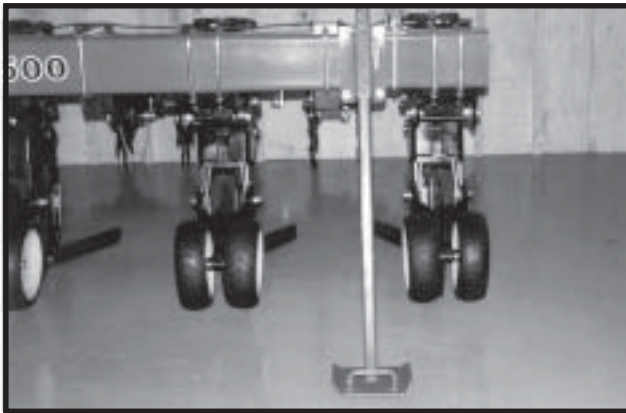

Two parking stands, located on the front side of the main frame, are standard on all Model 1500 Conservation Cultivators. The stands must be positioned so they are not directly behind the tractor tire or they will contact the tires when the cultivator is raised.

Raise to top position and pin during operation. Lower and pin for parking and storage.

Each parking stand has six positioning holes. By using these positioning holes, you can set the main frame height from 30" (76.2 cm) to 37" (94.0 cm).

## DOUBLE EDGE SHARES

63758-1

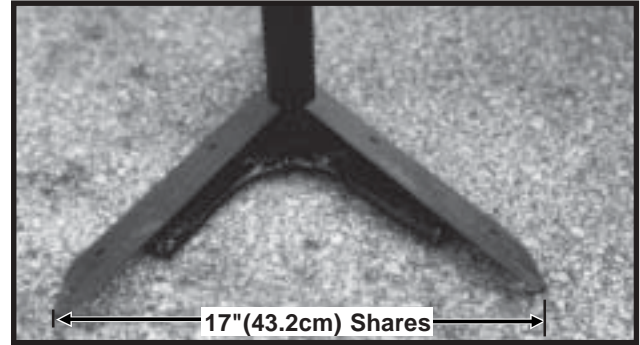

17", 19", 21", 25" and 27" (43.2 cm, 48.3 cm, 53.3 cm, 63.5 cm and 68.6 cm) regular or hard surface reversible double edge shares are available for use. On 30" (76 cm) row machines, 21" or 19" (53.3 cm or 48.3 cm) shares are recommended for first cultivation and 17" (43.2 cm) shares for second cultivation. On 36" - 40" (91 cm-102 cm) row machines, 27" (68.6 cm) shares are recommended for first cultivation and 25" or 21" (63.5 cm or 53.3 cm) shares for second cultivation.

# OPERATION

## LEVELING THE CULTIVATOR

L-0129(CLT6)

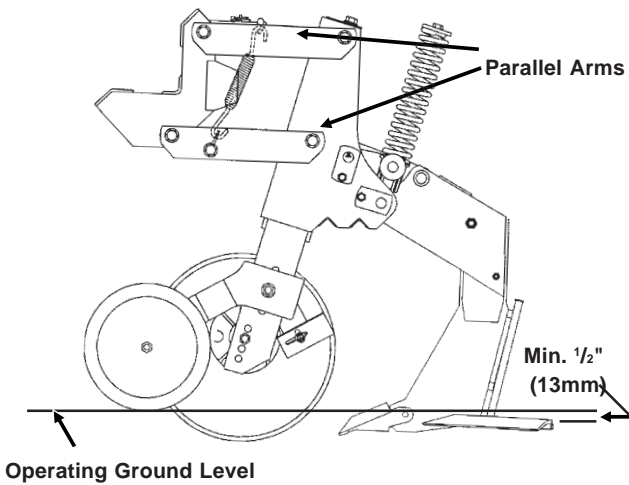

Rear top edge of share should run at a minimum of 1/2" (13 mm) below ground level. Deeper if necessary.

It is critical that the parallel arms of the individual row units be nearly level in operation. This will allow 10" (254 mm) total vertical row unit movement [5" (127 mm) up and 5" (127 mm) down] and maintain uniform ground penetration on irregular surfaces. The down pressure springs on each row unit will "borrow" weight from the others if that individual row unit encounters harder ground and prevent "riding out" or plugging of the row unit.

**To level side to side**, adjust so both lower lift arms on the tractor are the same distance off the ground.

**To level front to rear** or the tilt of the cultivator, change the length of the upper link on the tractor with the adjusting handle.



**WARNING:** Never work under the cultivator while in raised position without using safety stands to safely support the machine.

## DOWN-FORCE SPRING ADJUSTMENT

All row units should be adjusted equally except the row units following the tractor wheels. Those rows will usually require increased down pressure. Deeper operating settings may require more down pressure.

### Style A

The two coil down-force springs located between the parallel arm linkage on each row unit allow maximum weight transfer for superior penetration. Initial setting of the 5/8" adjusting bolt is 1 1/4" (32 mm) between the bottom of the upper parallel arm plate and the top of the spring plate.

L-0129(CLT7)

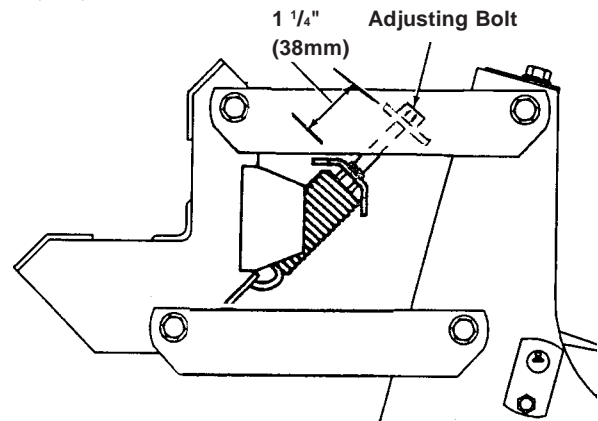

To increase down pressure, turn the 5/8" adjusting bolt clockwise.

**NOTE:** DO NOT tighten the adjusting bolt so tight that the spring mounting bolts contact the upper parallel arm plate. Damage to the springs will occur.

**IMPORTANT:** Over tightening down-force springs can cause up-lift on the cultivator toolbar. If this occurs, back off down-force spring adjustment bolt.

# OPERATION

## Style B

The four coil down-force springs located between the parallel arm linkage on each row unit allow maximum weight transfer for superior penetration.

(CLT8) TOP VIEW

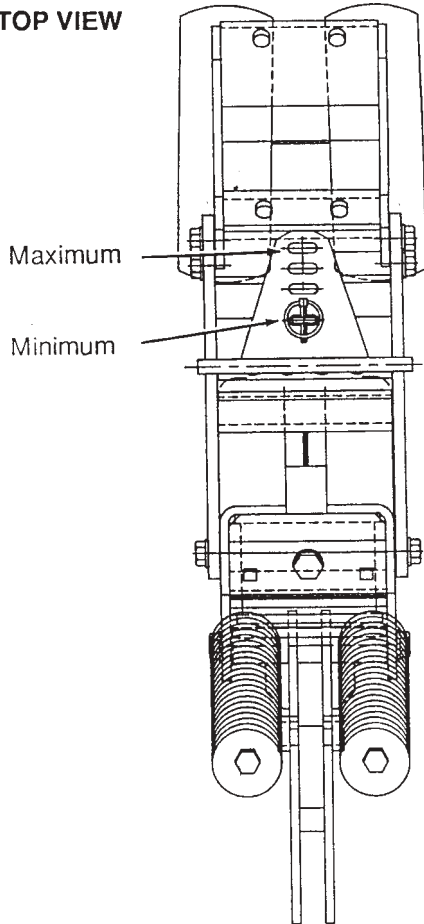

Initial setting is at minimum down pressure. To increase down pressure, as required for conditions, remove lynch pin and relocate the spring anchor tab in one of the forward locations. Reinstall lynch pin. See "Troubleshooting".

**NOTE:** Cultivator must be in the raised position when making down pressure adjustments.



**WARNING:** Never work under the cultivator while in raised position without using safety stands to safely support the machine.

## OPERATING DEPTH ADJUSTMENT

The screw-type depth adjustment bolt on each row unit allows depth adjustment settings from 0 to 6 as indicated on the scale setting.

L-0129(CLT6)

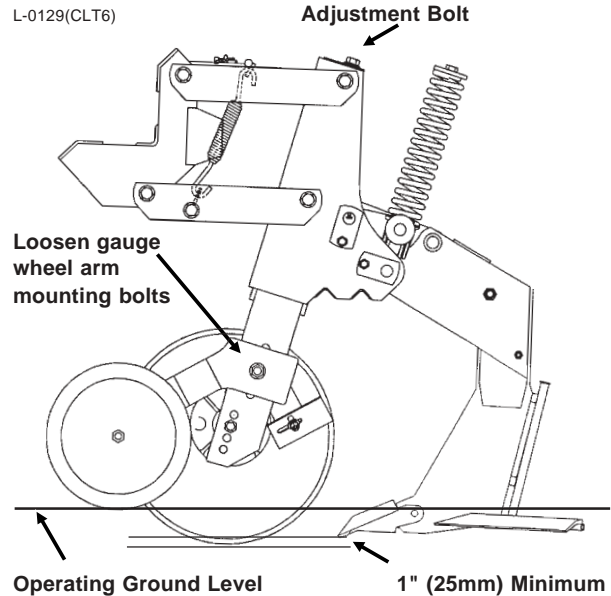

70691-29

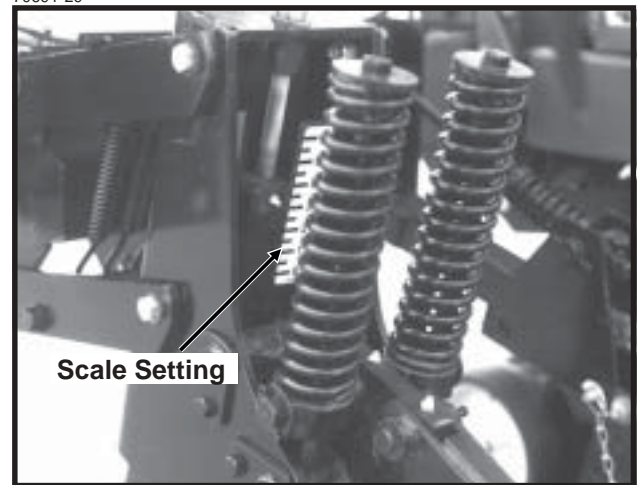

To adjust cutting depth, loosen gauge wheel arm mounting bolts and turn depth adjustment bolt clockwise (toward setting "6") to increase cutting depth or counterclockwise (toward setting "0") to decrease cutting depth. Adjust all rows equally. After coulters cutting depth adjustments are made, tighten gauge wheel arm mounting bolts to specified torque.

Hill side operation may require deeper coulters settings to help stabilize the machine. Deeper coulters settings may require additional down-force spring pressure. See "Down-Force Spring Adjustment".

# OPERATION

## COULTER BLADE ADJUSTMENT

The  $\frac{5}{8}$ " spindle which attaches the 18" (457 mm) diameter coulters on each row unit is adjustable in 1" (25 mm) increments (4 position) to compensate for blade wear. Initial position of the coulters should be the second hole from the top. Minimum coulters cutting depth should be 1" (25 mm) deeper than the shank point.

In extreme soft conditions, run the blade to maximum depth to prevent hair pinning or as deep as necessary for cutting material. Adjust coulters blade up as needed in extreme hard conditions to prevent the coulters blade from lifting the row unit up.

## SCRAPER ADJUSTMENT

The scraper on each coulters may be adjusted to compensate for wear that may occur. Set scraper blades with  $\frac{1}{32}$ " to  $\frac{1}{16}$ " (.8 mm to 1.6 mm) clearance to blade. Rotate blade after setting scrapers.

L-0129(CLT6)

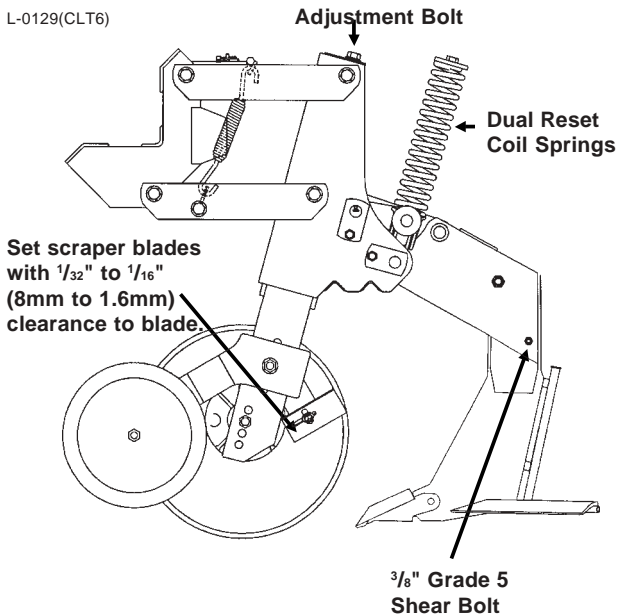

## SHANK TRIP

The dual automatic reset coil springs are factory set for normal operating conditions. If spring trips and will not reset, tighten both adjustment bolts the same amount. Maximum trip pressure is achieved by tightening the adjustment bolt to the end of the threads.

A  $\frac{3}{8}$ " Grade 5 shear bolt located between the shank mount and the shank adds additional protection for the shank assembly. When the pin is sheared the shank assembly will swing back to allow travel over protruding objects. Replace with like size and grade if bolt shears.

## TIRE PRESSURE

Tire pressure should be checked regularly and maintained as follows (if applicable):

7.60" x 15", 4 Ply ..... 40 PSI(276 kPa)

**IMPORTANT:** Tire pressure must be correctly maintained in all drive wheel tires to insure proper operation of the liquid fertilizer piston pump. All rate charts are based on rolling radius of 7.60" x 15" tires inflated to 40 PSI(276 kPa).



**DANGER:** Rim and tire servicing can be dangerous. Explosive separation of a tire and rim parts can cause serious injury or death.

## TRANSPORTING THE CULTIVATOR



**WARNING:** Always make sure flashing lights, reflectors and SMV emblem are in place and visible prior to transporting the machine on public roads. In this regard, check and comply with all federal, state and local regulations.



**WARNING:** Limit transport speed to 15 MPH (24 kmph). Transport only with farm tractor of sufficient size and horsepower.

## OPERATING SPEED

Recommended operating speed is 5 to 8 MPH (8 to 12 kmph).

See "Troubleshooting".

# OPERATION

## FIELD TEST

A field test of the cultivator should be made prior to initial operation and periodically thereafter to ensure proper operation.

- Check the cultivator for fore and aft and lateral level operation. See “Leveling The Cultivator”.
- Check all row units to be certain they are running level. When in operation, the row unit parallel arms should be parallel to the ground.
- Check for proper application rates. (If Applicable) See “Checking Application Rates”.

After the cultivator has been field tested, reinspect the machine.

- Bolts and nuts.
- Cotter pins and roll pins.
- Drive chain alignment and tension (If Applicable).
- Hoses and fittings (If Applicable).

## METRIC CONVERSION TABLE

Multiply	By	To Get
Inches (in.)	x 2.54	= centimeters (cm)
Inches (in.)	x 25.4	= millimeters (mm)
Feet (ft.)	x 30.48	= centimeters (cm)
Acres	x 0.405	= hectares (ha)
Miles per hour (mph)	x 1.609	= kilometers per hour (kmph)
Pounds (lbs.)	x 0.453	= kilograms (kg)
Bushels (bu.)	x 35.238	= liters (l)
Gallons (gal.)	x 3.785	= liters (l)
Pounds per square inch (psi)	x 6.894	= kilopascals (kPa) (100 kPa = 1 bar)
Inch pounds (in. lbs.)	x 0.113	= newtons-meters (N·m)
Foot pounds (ft. lbs.)	x 1.356	= newtons-meters (N·m)
Centimeters (cm)	x .394	= inches (in.)
Millimeters (mm)	x .0394	= inches (in.)
Centimeters (cm)	x .0328	= feet (ft.)
Hectares (ha)	x 2.469	= acres
Kilometers per hour (kmph)	x 0.621	= miles per hour (mph)
Kilograms (kg)	x 2.208	= pounds (lbs.)
Liters (l)	x 0.028	= bushels (bu.)
Liters (l)	x 0.264	= gallons (gal.)
Kilopascals (kPa) (100 kPa = 1 bar)	x 0.145	= pounds per square inch (psi)
Newtons-meters (N·m)	x 8.85	= inch pounds (in. lbs.)
Newtons-meters (N·m)	x 0.738	= foot pounds (ft. lbs.)

# OPERATION

## TROUBLESHOOTING

PROBLEM	POSSIBLE CAUSE	POSSIBLE SOLUTION
Cultivator does not lift clear of the ground.	Lift arms not adjusted to lift as high as possible.	Turn screw adjustment cranks to raise lift arms to maximum level.
Cultivator does not ride or operate level.	Lift arms uneven.	Check height adjustment arms on lift arms with tape measure. Be sure both are even. Check air pressure in rear tires and inflate properly and evenly to carry toolbar level. All adjustments on three-point should work freely, especially top linkage arm.
Residue plugging between coulter and shank.	Row unit riding out (gauge wheels off ground).  Coulter not cutting residue.	Worn points or shares.  Coulter set too deep.  Set coulter deeper. See "Coulter Depth Adjustment".  Set more or less down pressure.
Residue plugging/bunching on end of shares.	Machine tipped too far forward.	Lengthen upper link on tractor.
Shank point not penetrating.	Worn points or shares.  Cutting coulter too deep.  Insufficient down pressure/ballast.  Machine tilted too far forward.  Hitch pins in lower holes.  Draft control.	Replace worn components.  Set only deep enough to fully cut residue.  Read "Leveling The Cultivator" and "Down-Force Spring Adjustment".  Lengthen upper link on tractor.  Raise lower link hitch pins to upper holes.  Adjust to position setting.
Plugging between cut-away and coulter.	Discs too close to row unit.  Discs too deep.	Move closer to row. Position blades to angle rearward.  Set to shallower setting.
Slabbing	Cultivator set too deep.  Machine tilted forward.  Slow tractor speed.	See depth control adjustments.  Lengthen upper link on tractor.  Better ground action occurs at 6-7 MPH (10-11 kmph).

# OPERATION

## TROUBLESHOOTING (Continued)

PROBLEM	POSSIBLE CAUSE	POSSIBLE SOLUTION
Weeds undercut but not destroyed.	Cultivator set too deep.  Too slow tractor speed.	Read depth control adjustments.  Better ground action occurs at 6-7 MPH (10-11 kmph).
Shares lifting ridge and crop.	Cultivator tilted to rear.  Wrong size shares.	Pitch machine forward with upper link on tractor.  Switch to smaller size as per instruction in "Double Edge Shares".
Rotary hoe wheels plugging.	Support arm too long.  No till conditions.	Set to 13 1/2" (343 mm) for 30" (76 cm) rows, 18" (457 mm) for 36" - 40" (91-102 cm) rows. (See "Rotary Hoe Crop Shields" in Operation Section.)  Run hoe wheels backward.
Gauge wheels bury (loose soil) or pushing.	Too much down-force on row units.	Decrease down pressure setting.
Gauge wheels ride out.	Not enough down-force on row units.	Increase down pressure setting.
Spring trip not tripping.	Pivot points seized up.	Lubricate reset linkage.
Parallel linkage will not flex.	Bushings frozen.  Bushing worn out.	Bushings in parallel linkage should be lubricated weekly. See "Lubrication". If parallel linkage sticks, lubricate and raise and lower cultivator until linkage is free.  Remove and replace.
Liquid fertilizer - No fertilizer.	Pump.	Check liquid pump for leaking or broken hoses.  Check pump drive for sheared pins or broken chain.  NOTE: Always wash spilled fertilizer from cultivator before storing.
Liquid fertilizer - Lower than anticipated rate.	Restriction in feed line to pump.  Air leak in feed line to pump.	Check for collapsed or pinched hose or restriction in line.  Check all fittings and connections. A fertilizer leak becomes an air leak when the pump is operating.

# OPERATION

## CUT-AWAY WEEDING DISCS ATTACHMENT

Two disc assemblies are used per row. Each disc assembly can be positioned to angle forward or rearward. In high trash conditions the disc assemblies should be positioned to angle rearward.

To reposition disc assembly to change angle of arm, remove each complete disc assembly from the mounting clamp and install in the opposite position. **The bend line on the disc mounting bar must always be vertical.** Remove the  $\frac{5}{8}$ " disc/hub mounting bolt and move the disc/hub assembly to the outer side of the arm.

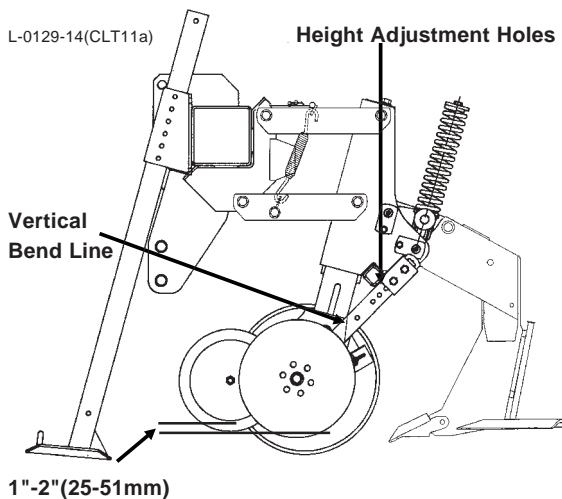

Disc assembly positioned to angle forward

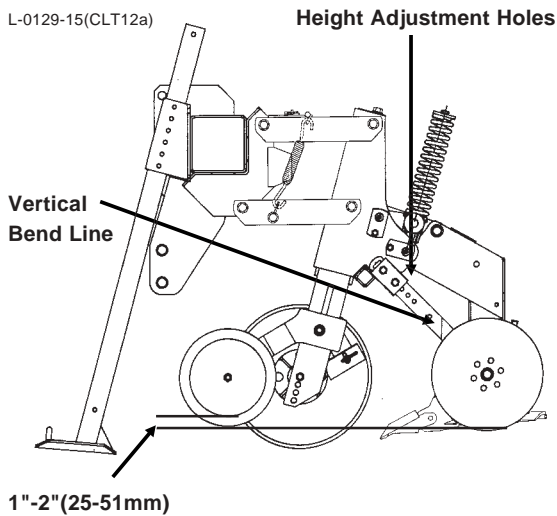

Disc assembly positioned to angle rearward

Six holes on each disc assembly arm allow for mounting height adjustment. Cut-away weeding discs should be positioned to move the desired amount of soil.

The disc mounting tubes can be slid in or out to allow different disc cutting widths. NEVER operate with the discs closer than 4" (102 mm) to the row.

When not in use, the disc assembly arm can be removed, inverted and stored in the upright position or locked up in the highest position.

Cut-away weeding discs are not recommended for row spacings less than 36" (91.4 cm).

## RIDGING ATTACHMENT

65909-10

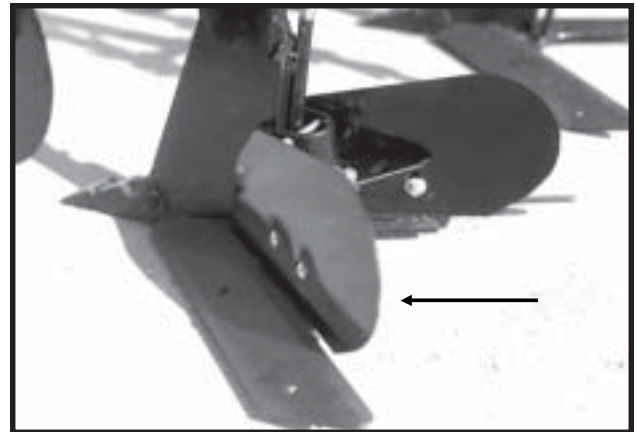

Short ridging blades are used for 30" (76.2 cm) row machines and long ridging blades for 36" - 40" (91.4 cm - 101.6 cm) row machines.

The bolt-on mounting bracket on each row unit allows for height adjustment which determines the amount of ground action. Locate the bracket as low as possible to build ridges. For less ground action and less ridging, raise the mounting bracket.

Slotted holes in each mounting bracket used for mounting the ridging blades also allow for additional adjustment. Locate the ridging blades even and level on the double edge shares to build ridges. For less ground action and less ridging, adjust the ridging blades higher in the slotted holes.

All rows should be adjusted the same.

Field adjustments should be made according to soil conditions and for desired results.

# OPERATION

## ROTARY HOE/ROLLING DISC CROP SHIELD WITH MOUNTING SUPPORT ATTACHMENT

The Rotary Hoe Crop Shield With Mounting Support consists of two 21 1/2" (546 mm) rotary hoe wheels per row which can be positioned with the fingers angling forward for less ground action or with the fingers angling rearward for additional tillage. In trashy conditions the wheels should be positioned with the fingers angling forward to prevent the trash from wrapping on the wheels.

63749-32

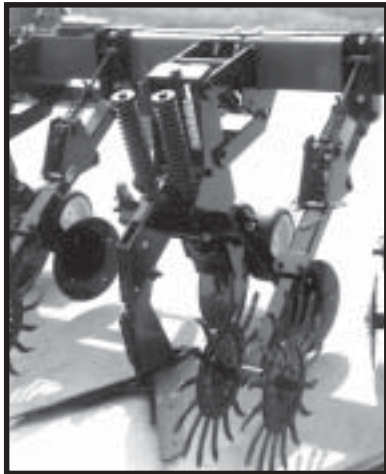

**Rotary Hoe Crop Shield Shown With Fingers Angling Forward**

The Rolling Disc Crop Shield With Mounting Support consists of two 19 5/8" (498 mm) diameter concave discs per row.

70584-3



**Rolling Disc Crop Shield Shown**

The length of the mounting support arm can be adjusted for various field conditions and share blade lengths. Set as required. Initial setting is 13 1/2" (343 mm) between center of 5/8" spindle and tube insertion point for 30" (76.2 cm) row machines and

18" (457 mm) for 36" through 40" (91.4 cm through 101.6 cm) row machines. Shields may have to be extended in very short crops and/or very loose soil.

A6193(CLT13)

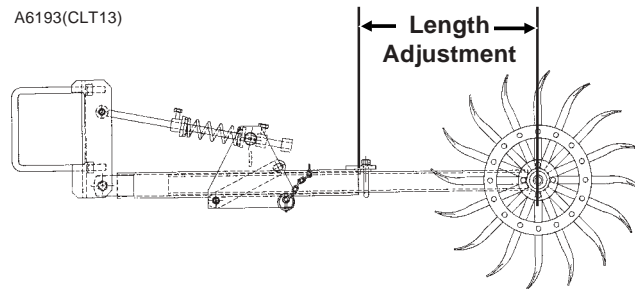

Moveable spacers on the 5/8" spindle which attach the wheels allow width adjustment.

CCU004(CLT14)

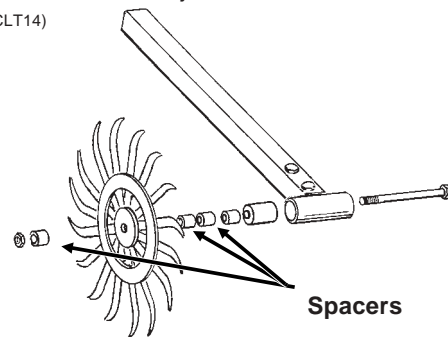

Crop shields should have sufficient down pressure and depth adjustment to keep the shields rotating. Too much down pressure and depth can cause the shields to throw dirt. To adjust depth, loosen the set screw on the **depth adjustment set collar** and slide the set collar rearward for added depth or forward for less depth. Tighten set screw. To adjust down pressure, loosen the set screw on the **down pressure adjustment set collar** and slide the set collar rearward for added down pressure or forward for less down pressure. Tighten set screw. Down pressure and depth should be the same on all rows.

A6193(CLT15)

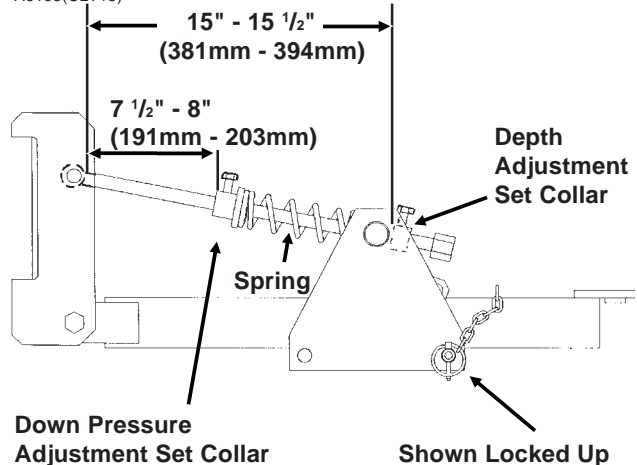

Crop shields can be locked up as shown above when not in use.

# OPERATION

## LIQUID FERTILIZER APPLICATION ATTACHMENT

65909-38

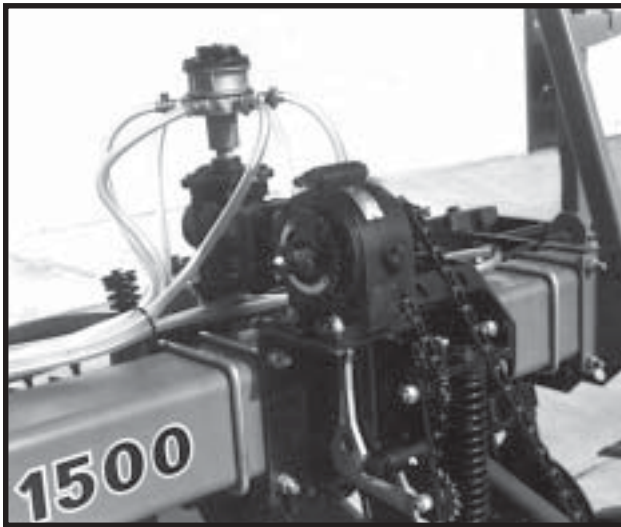

The Liquid Fertilizer Application Attachment includes one John Blue L-4405 piston pump and flow divider for precise application of liquid fertilizer solutions to all rows. The rate of application is determined by the piston pump setting.

The operator and instruction manuals shipped with the metering pump and flow divider should be kept and stored with this manual for future reference.

The delivery rate chart found on the next page provides an approximate application rate only. Actual delivery will vary with temperature and the product and row spacings being used.

"T" fertilizer tubes welded to the back and underside of the row unit shank place side-dress liquid fertilizer approximately 10" (254 mm) from the row (30" rows [76 cm]) and to the depth the cultivator is set.

Consistent drive is provided by a spring-loaded 7.60" x 15" ground drive tire. When the liquid fertilizer application attachment is not in use, the drive tire can be locked up in the storage position.

65909-55



65909-1



# OPERATION

---

## CHECKING APPLICATION RATES

Use the following procedure to check the amount of fertilizer being applied at a given setting.

1. Set up a system to catch all of the material that will be applied on the calibration run.
2. Travel the distance needed for  $\frac{1}{10}$  of an acre.
3. Multiply by 10 the amount of material collected to get the gallons (liters) per acre. (Multiply liters per acre by 2.469 to get liters per hectare.)

**NOTE: Be sure to exclude the weight of the collection container in the calculations.**

TRAVEL DISTANCE FOR $\frac{1}{10}$ OF AN ACRE				
Machine Size	30" (76.2 cm)	36" (91.4 cm)	38" (96.5 cm)	40" (101.6 cm)
4 Row	435.6 ft. (13,277 cm)	363.0 ft. (11,064 cm)	344.0 ft. (10,485 cm)	326.8 ft. (9961 cm)
6 Row	290.4 ft. (8851 cm)	242.0 ft. (7376 cm)	229.3 ft. (6989 cm)	217.8 ft. (6639 cm)
8 Row	217.8 ft. (6639 cm)	181.5 ft. (5532 cm)	172.0 ft. (5243 cm)	163.8 ft. (4993 cm)
10 Row	174.2 ft. (5310 cm)	145.2 ft. (4426 cm)	137.6 ft. (4194 cm)	130.7 ft. (3984 cm)
12 Row	145.2 ft. (4426 cm)	121.0 ft. (3688 cm)	114.7 ft. (3496 cm)	108.9 ft. (3319 cm)
16 Row	108.9 ft. (3319 cm)	90.8 ft. (2768 cm)	86.0 ft. (2621 cm)	81.7 ft. (2490 cm)

# OPERATION

## LIQUID FERTILIZER APPLICATION RATES

### GALLONS PER ACRE (Liters/Hectare)

Pump Setting	1	2	3	4	5	6	7	8	9	10
4 Row 30"	12 (112)	24 (224)	36 (336)	48 (449)	60 (561)	72 (673)	84 (785)	96 (897)	108 (1009)	120 (1121)
4 Row 36"	10 (93)	20 (187)	30 (280)	40 (374)	50 (467)	60 (561)	70 (654)	80 (748)	90 (841)	100 (935)
4 Row 38"	9 (84)	19 (178)	28 (262)	38 (355)	47 (439)	57 (533)	66 (617)	76 (710)	85 (794)	94 (878)
4 Row 40"	9 (84)	18 (168)	27 (252)	36 (336)	45 (421)	54 (505)	63 (589)	72 (673)	81 (757)	90 (841)
6 Row 30"	8 (75)	16 (150)	24 (224)	32 (299)	39 (364)	48 (449)	55 (514)	63 (589)	71 (664)	80 (748)
6 Row 36"	7 (65)	13 (121)	20 (187)	27 (252)	32 (299)	40 (374)	46 (430)	52 (486)	59 (551)	66 (617)
6 Row 38"	7 (65)	13 (121)	19 (178)	25 (234)	31 (290)	38 (355)	44 (411)	50 (467)	56 (523)	63 (589)
6 Row 40"	6 (56)	12 (112)	18 (168)	24 (224)	29 (271)	36 (336)	41 (383)	47 (439)	53 (495)	60 (561)
8 Row 30"	6 (56)	12 (112)	18 (168)	24 (224)	30 (280)	36 (336)	42 (392)	48 (449)	54 (505)	60 (561)
8 Row 36"	5 (47)	10 (93)	15 (140)	20 (187)	25 (234)	30 (280)	35 (327)	40 (374)	45 (421)	50 (467)
8 Row 38"	4 (37)	9 (84)	14 (131)	19 (178)	24 (224)	28 (262)	33 (308)	38 (355)	43 (402)	47 (439)
8 Row 40"	4 (37)	9 (84)	14 (131)	18 (168)	23 (215)	27 (252)	32 (299)	36 (336)	41 (383)	45 (421)
10 Row 30"	5 (45)	10 (90)	14 (134)	19 (180)	24 (224)	29 (269)	34 (314)	38 (359)	43 (404)	48 (448)
12 Row 30"	4 (37)	8 (75)	12 (112)	16 (150)	20 (187)	24 (224)	28 (262)	32 (299)	36 (336)	40 (374)
12 Row 36"	4 (37)	7 (65)	10 (93)	14 (131)	16 (150)	20 (187)	23 (215)	26 (243)	30 (280)	33 (308)
12 Row 38"	4 (37)	7 (65)	10 (93)	13 (121)	16 (150)	19 (178)	22 (206)	25 (234)	28 (262)	32 (299)
16 Row 30"	3 (28)	6 (56)	9 (84)	12 (112)	15 (140)	18 (168)	21 (196)	24 (224)	27 (252)	30 (280)

Above chart is for cultivators equipped with 7.60" x 15" drive wheel, based on 96" (2438 mm) forward travel per cultivator wheel revolution, 48 tooth drive sprocket and 18 tooth driven sprocket on metering pump. Chart is based on average wheel slippage and liquid viscosities.

Measure and weigh one gallon (one liter) of actual fertilizer solution to determine exact application rate. This chart was calculated based on a solution weighing ten pounds per gallon.

**IMPORTANT:** Fertilizer application rates can vary from the above chart. To prevent application miscalculations, make field checks to be sure you are applying fertilizer to all rows at the desired rate.

**NOTE:** Flow to all rows should be checked periodically. If one or more lines are plugged, the desired rate will be delivered to the remaining rows keeping total application rate at desired rate.

# OPERATION

## REAR TELESCOPING HITCH ATTACHMENT

70723-8

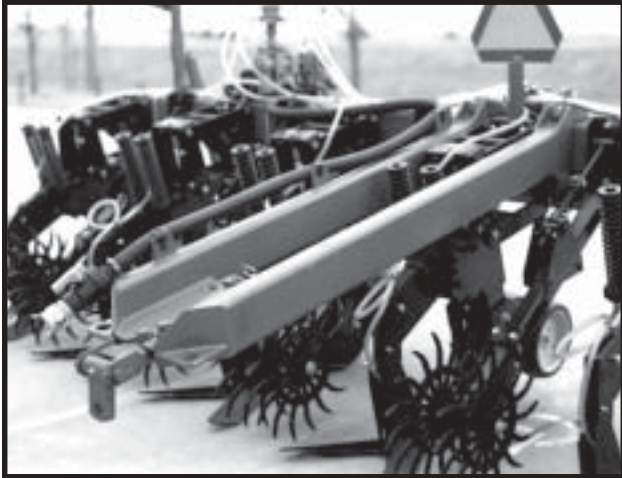

**Toolbar Mounted Rear Telescoping Hitch**

73593-25



**Dual Lift Assist Wheel Mounted Rear Telescoping Hitch**

6" hitch extensions are available for use with the toolbar mounted rear telescoping hitch. Hitch extensions are required when using the coil anhydrous shank with the toolbar mounted rear telescoping hitch to allow clearance for the cultivator shank trip mechanism to operate.

70723-2



The telescoping hitch allows easy wagon hookup with 8" of extension and 4" of side-to-side movement.

70723-28



**Locked Position For Field Operation**

70723-25

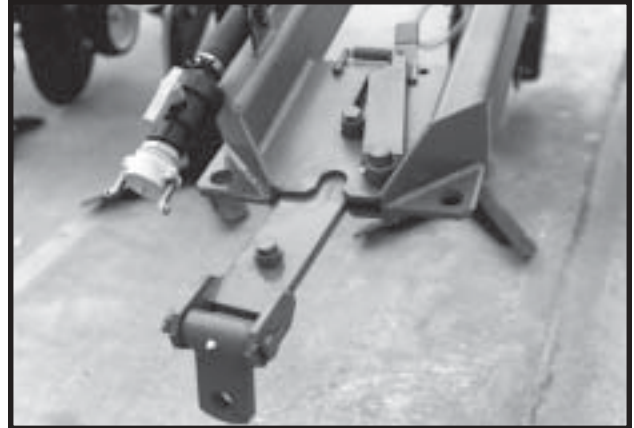

**Extended Position For Easier Hookup**

# OPERATION

## COIL ANHYDROUS SHANK WITH KNIFE MOUNT ATTACHMENT

70584-10



The Coil Anhydrous Shank With Knife Mount includes 1 1/4" square spring coil anhydrous shanks, mounts and mounting hardware to attach the shanks to the cultivator row unit and knife mounting brackets and hardware to install customer-supplied knives.

**NOTE:** "Beavertails" are recommended on customer-supplied knives.

## DUAL LIFT ASSIST WHEELS ATTACHMENT

70691-24



Dual lift assist wheels are recommended on some size folding cultivators depending on size of tractor being used with the cultivator.

Dual lift assist wheel equipped machines require use of a quick hitch (customer-supplied) and the top link pin is not used.

A single control valve operates the dual lift assist wheels.

When raising a cultivator equipped with dual lift assist wheels, the front of the cultivator should begin to raise first. The rear of the cultivator should then raise using the lift assist wheels. When lowering the cultivator, the lift assist wheels should begin to lower the rear of the cultivator before lowering the front of the cultivator.

Dual lift assist wheels hydraulics can also be plumbed into the 3 point lift circuit. A flow control valve determines the correct sequence of events to allow the dual lift assist wheel cylinders to operate at the correct time in conjunction with the 3 point hitch lift circuit. See "Flow Control Valve Adjustment".

See "Tractor Preparation And Hookup" for additional information.

Dual lift assist wheels are not compatible with the optional toolbar mounted rear telescoping hitch.

## FLOW CONTROL VALVE ADJUSTMENT

WB001(MT2)

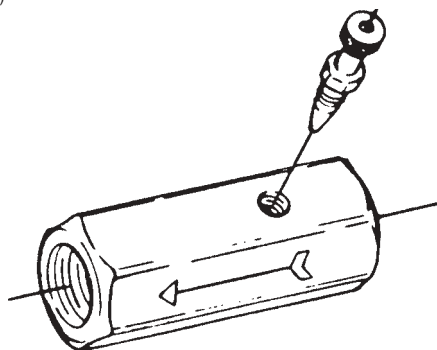

The flow control valve determines the amount of oil flow to the lift assist cylinders.

To adjust oil flow, loosen the jam nut and turn the control clockwise or "in" to restrict flow and counterclockwise or "out" to increase the flow.

# OPERATION

---

# LUBRICATION

The following pages show the locations of all lubrication points. Proper lubrication of all moving parts will help ensure efficient operation of your KINZE® cultivator and prolong the life of friction producing parts.



**DANGER:** Never work under or ride on the cultivator while it is in the raised position or while it is in operation.

## LUBRICATION SYMBOLS

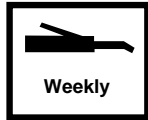
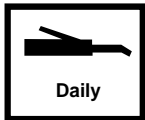

Lubricate at frequency indicated with an SAE multipurpose type grease.

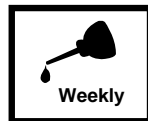

Lubricate at frequency indicated with a high quality SAE 10 weight oil or a quality spray lubricant.

## SEALED BEARINGS

L-0129(CLT6)

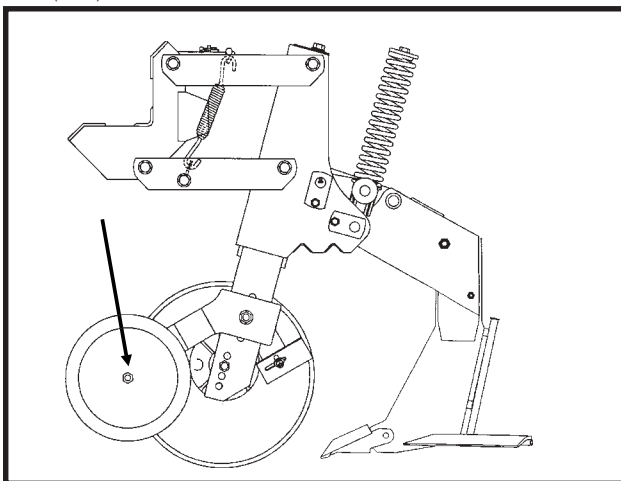

A number of sealed bearings are used on your KINZE® cultivator to provide trouble free operation. These are located in such areas as the depth gauge wheels, cut-away weeding disc hubs, rotary hoe crop shield wheels and idler sprockets. Sealed bearings are lubricated for life, and due to the seals, relubrication is not practical.

## BUSHINGS

Lubricate bushings at the frequency indicated.

Using a wrench, check each bolt for looseness. If bolt is loose, it should be removed and the bushing inspected for cracks and wear. Replace bushing if necessary. **Only hardened flat washers should be used. Replace damaged flat washers with proper part. Torque bolt to 130 ft. lbs. (176 N·m).**

L-0129(CLT6)

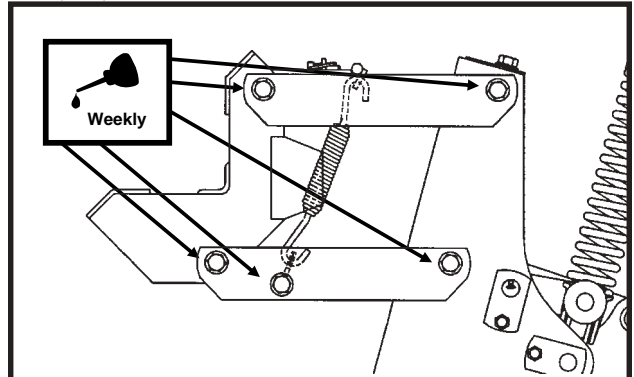

**Row Unit Parallel Arms (8 per row)**  
**Lower Spring Anchor Tab (2 per row) (If Applicable)**

65909-43

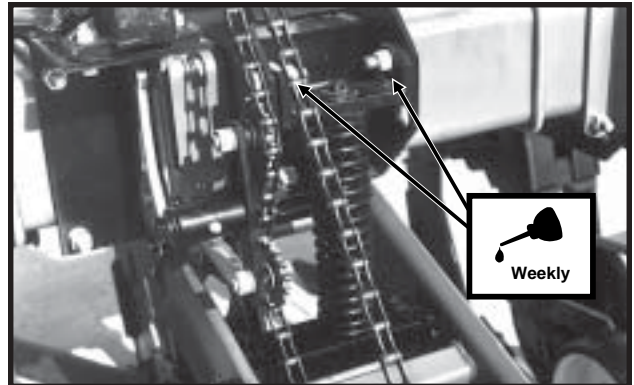

**Liquid Fertilizer Drive Wheel Down Pressure Spring Mount (2 per spring)**

A6193(CLT15)

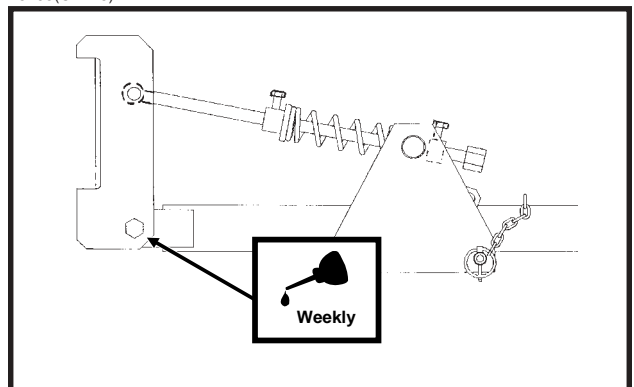

**Rotary Hoe/Rolling Disc Crop Shield (2 per row)**

# LUBRICATION

## LIQUID FERTILIZER DRIVE CHAIN

65909-43

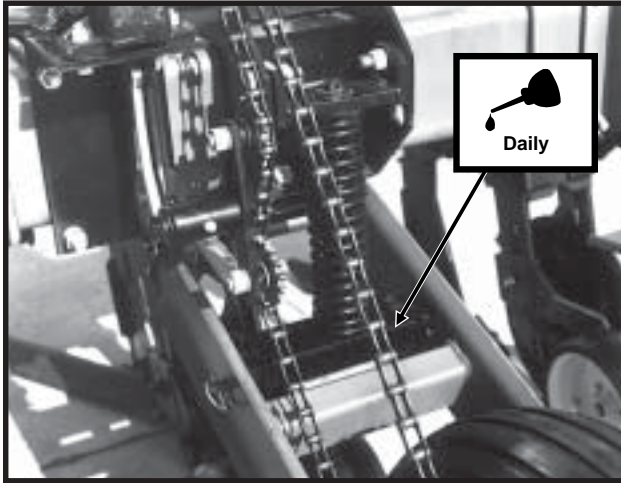

The liquid fertilizer drive chain should be lubricated daily with a high quality SAE 10 weight oil or a quality spray lubricant. Extreme operating conditions such as dirt, temperature or speed may require more frequent lubrication. If the chain becomes stiff, it should be removed, soaked and washed in solvent to loosen and remove dirt from the joints. Then soak the chain in oil so the lubricant can penetrate between the rollers and bushings.

## WHEEL BEARINGS (Dual Lift Assist/ Liquid Fertilizer Drive)

Wheel bearings should be repacked with clean, heavy duty wheel bearing grease approximately once a year or at the beginning of each season. Follow the procedure outlined for wheel bearing replacement with the exception that bearings and bearing cups are reused.

Lift wheel off the ground. Check for endplay in the bearings by moving the tire in and out. Rotate the tire to check for roughness in the bearings. If bearings sound rough, the hub should be removed and the bearings inspected and replaced if necessary. See "Wheel Bearing Lubrication Or Replacement".

## GREASE FITTINGS

Those parts equipped with grease fittings should be lubricated at the frequency indicated with an SAE multipurpose type grease. Be sure to clean the fitting thoroughly before using grease gun. The frequency of lubrication recommended is based on normal operating conditions. Severe or unusual conditions may require more frequent attention.



**DANGER:** Always lower to the ground before working under or around the machine.

63758-21

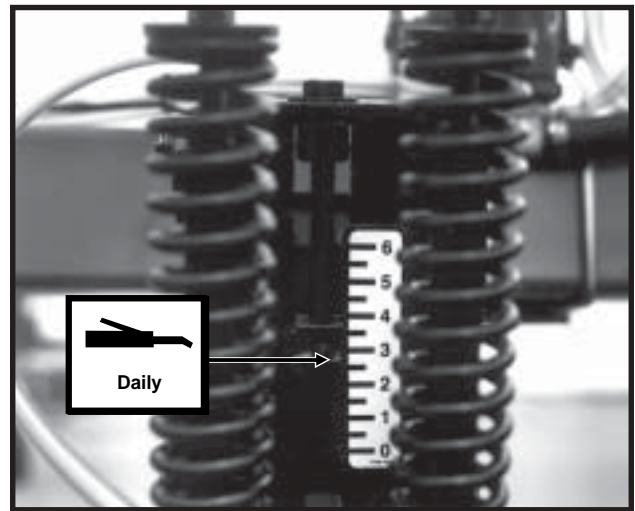

1. Coulter adjustment fork - 1 zerk per row unit.

65909-37

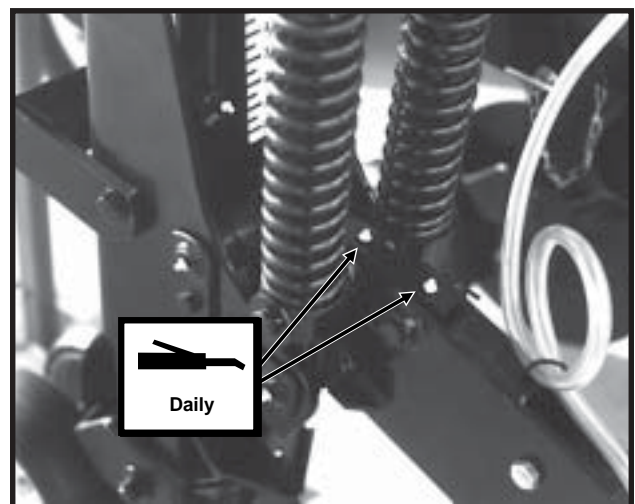

2. Spring reset linkage - 2 zerks per row unit.

# LUBRICATION

05209820

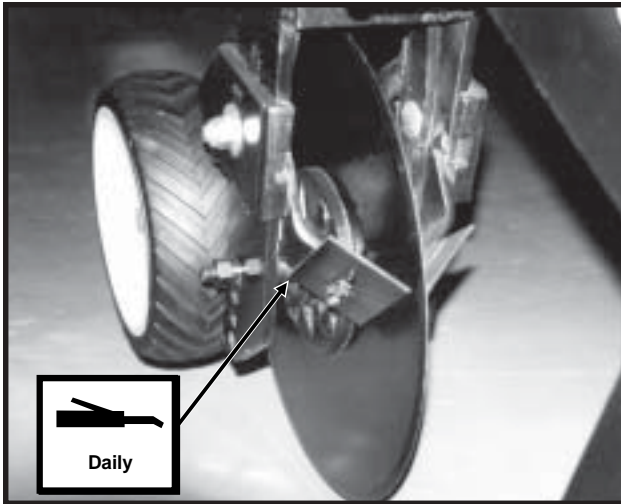

3. Row unit coulters hub - 1 zerk per row unit.  
**NOTE: Pump grease into hub until grease comes out around the seals.**

65909-42

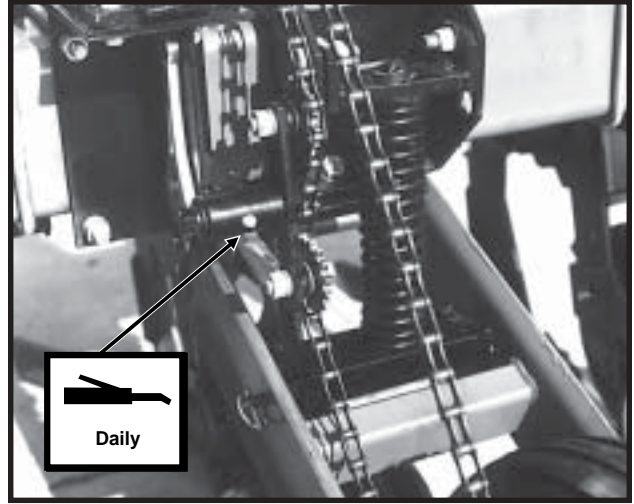

6. Liquid fertilizer idler bracket - 1 zerk.

70691-28

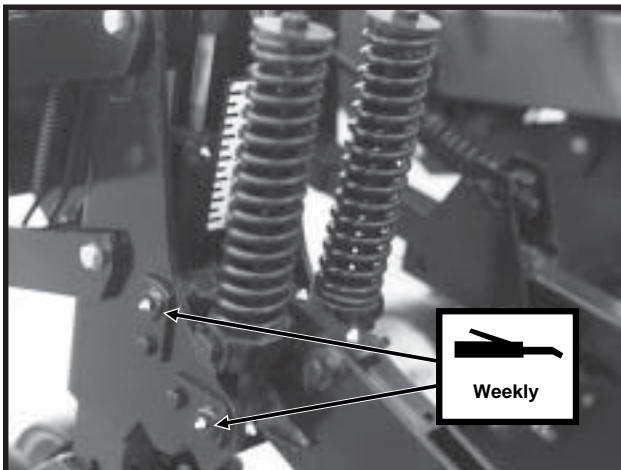

4. Spring reset mounting hammer straps and springs - 4 zerks per row unit.

70691-40

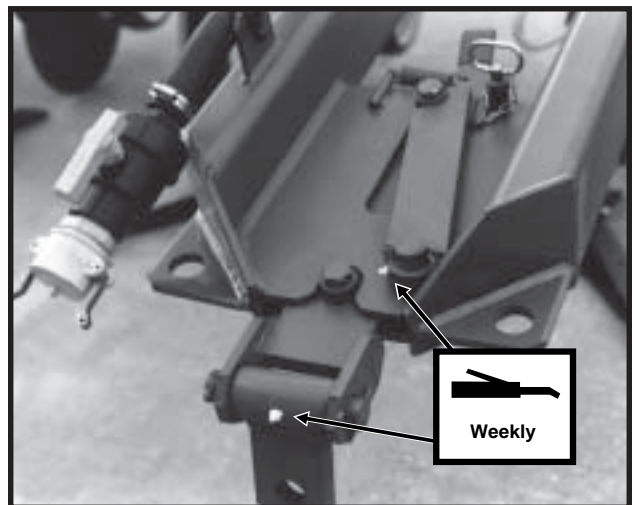

7. Rear telescoping hitch clevis - 1 zerk.  
8. Rear telescoping hitch hook - 1 zerk.

70691-35

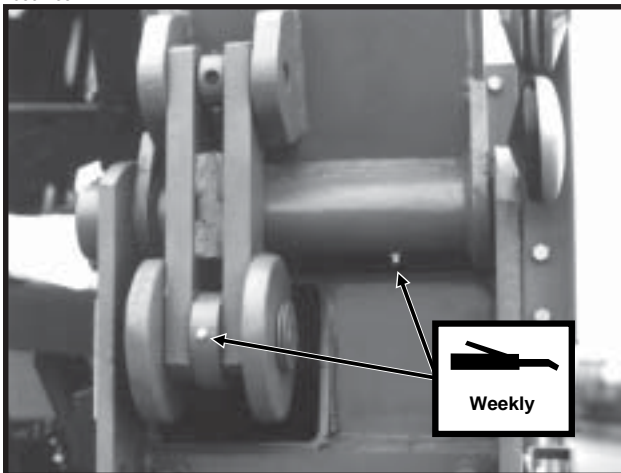

5. Wing hinge (Folding Machines) - 1 zerk per cylinder/1 zerk per hinge pin.

# LUBRICATION

---

70691-8

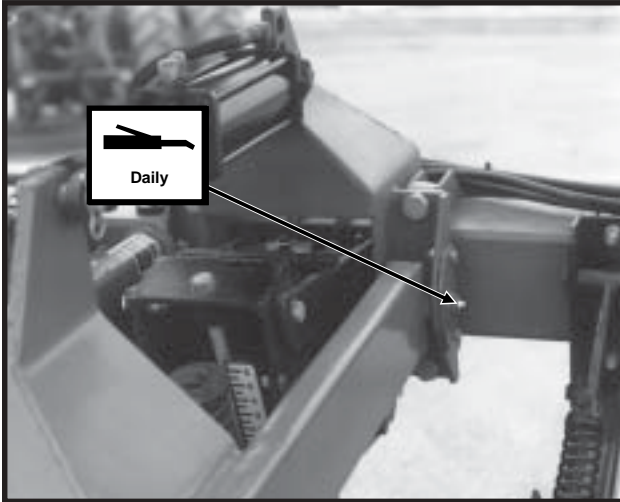

9. Dual lift assist wheel hammer strap - 2 zerks per wheel assembly.

70691-32

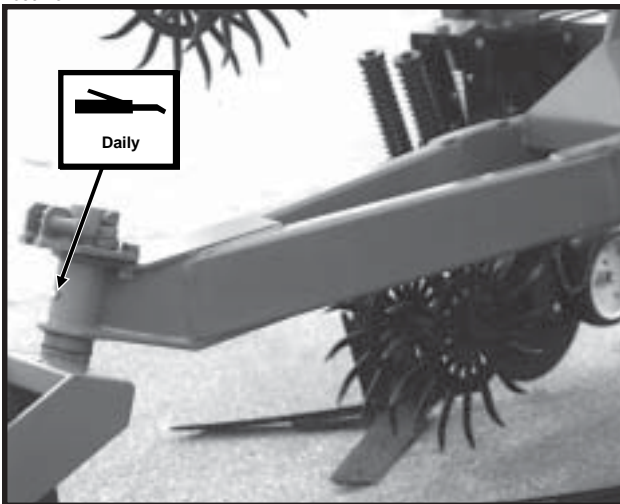

10. Dual lift assist caster wheel - 1 zerk per wheel assembly.

# MAINTENANCE

## MOUNTING BOLTS AND HARDWARE



Before operating the cultivator for the first time, check to be sure all nuts and bolts are tight. Check all nuts and bolts again after approximately the first 50 hours of operation and at the beginning of each cultivation season thereafter.

All bolts used on the KINZE® cultivator are Grade 5 (high strength) unless otherwise noted. Refer to the torque values chart when tightening bolts.

**NOTE: Over tightening bolts can cause as much damage as under tightening. Tightening a bolt beyond the recommended range can reduce its shock load capacity.**

TORQUE VALUES CHART - PLATED HARDWARE						
Bolt Diameter	Grade 2		Grade 5		Grade 8	
	Coarse	Fine	Coarse	Fine	Coarse	Fine
1/4"	50 In. Lbs.	56 In. Lbs.	76 In. Lbs.	87 In. Lbs.	9 Ft. Lbs.	10 Ft. Lbs.
5/16"	8 Ft. Lbs.	9 Ft. Lbs.	13 Ft. Lbs.	14 Ft. Lbs.	18 Ft. Lbs.	20 Ft. Lbs.
3/8"	15 Ft. Lbs.	17 Ft. Lbs.	23 Ft. Lbs.	26 Ft. Lbs.	33 Ft. Lbs.	37 Ft. Lbs.
7/16"	25 Ft. Lbs.	27 Ft. Lbs.	37 Ft. Lbs.	41 Ft. Lbs.	52 Ft. Lbs.	58 Ft. Lbs.
1/2"	35 Ft. Lbs.	40 Ft. Lbs.	57 Ft. Lbs.	64 Ft. Lbs.	80 Ft. Lbs.	90 Ft. Lbs.
9/16"	50 Ft. Lbs.	60 Ft. Lbs.	80 Ft. Lbs.	90 Ft. Lbs.	115 Ft. Lbs.	130 Ft. Lbs.
5/8"	70 Ft. Lbs.	80 Ft. Lbs.	110 Ft. Lbs.	125 Ft. Lbs.	160 Ft. Lbs.	180 Ft. Lbs.
3/4"	130 Ft. Lbs.	145 Ft. Lbs.	200 Ft. Lbs.	220 Ft. Lbs.	280 Ft. Lbs.	315 Ft. Lbs.
7/8"	125 Ft. Lbs.	140 Ft. Lbs.	320 Ft. Lbs.	350 Ft. Lbs.	450 Ft. Lbs.	500 Ft. Lbs.
1"	190 Ft. Lbs.	205 Ft. Lbs.	480 Ft. Lbs.	530 Ft. Lbs.	675 Ft. Lbs.	750 Ft. Lbs.
1 1/8"	265 Ft. Lbs.	300 Ft. Lbs.	600 Ft. Lbs.	670 Ft. Lbs.	960 Ft. Lbs.	1075 Ft. Lbs.
1 1/4"	375 Ft. Lbs.	415 Ft. Lbs.	840 Ft. Lbs.	930 Ft. Lbs.	1360 Ft. Lbs.	1500 Ft. Lbs.
1 3/8"	490 Ft. Lbs.	560 Ft. Lbs.	1100 Ft. Lbs.	1250 Ft. Lbs.	1780 Ft. Lbs.	2030 Ft. Lbs.
1 1/2"	650 Ft. Lbs.	730 Ft. Lbs.	1450 Ft. Lbs.	1650 Ft. Lbs.	2307 Ft. Lbs.	2670 Ft. Lbs.

**NOTE: Unplated hardware and bolts with lock nuts should be torqued approximately 1/3 higher than the above values. Bolts lubricated prior to installation should be torqued to 70% of value shown in chart.**

	<b>GRADE 2</b> No Marks		<b>GRADE 5</b> 3 Marks		<b>GRADE 8</b> 6 Marks
---	----------------------------	---	---------------------------	---	---------------------------

## BUSHINGS

Bushings are used in several locations on the KINZE® cultivator. Lubricate bushings as outlined in "Lubrication".

Using a wrench, check each bolt for looseness. If bolt is loose, it should be removed and the bushing inspected for cracks and wear. Replace bushing if necessary. **Only hardened flat washers should be used. Replace damaged flat washers with proper part. Torque bolt to 130 ft. lbs. (176 N-m).**

70691-27

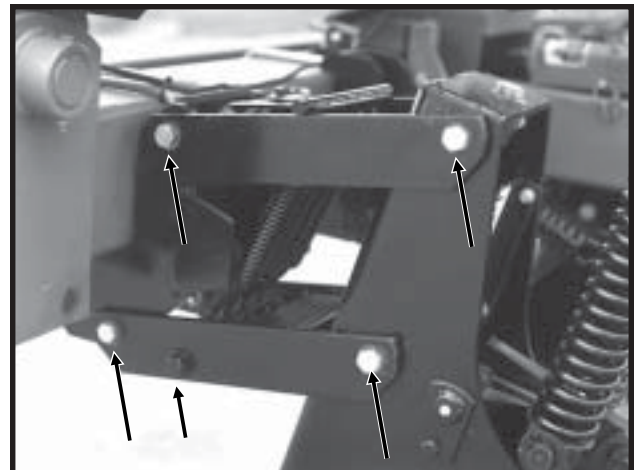

# MAINTENANCE

## ROW UNIT COULTER

05209820

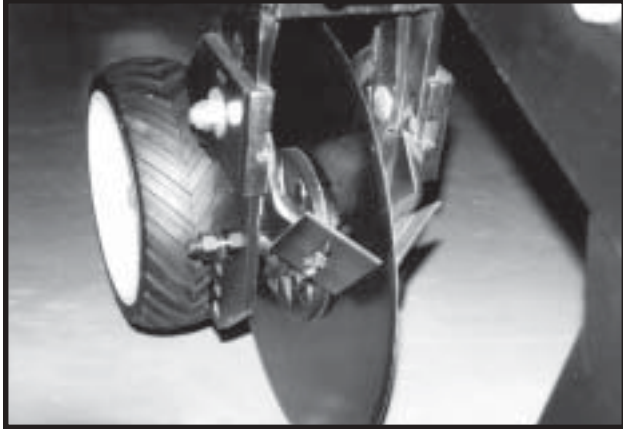

If properly maintained and lubricated the bearings in the row unit coulters hub may never need to be replaced. Lubricate at frequency indicated in the lubrication section of this manual. Check periodically to be sure nuts and hardware are tightened to proper torque specification.

The coulters blade can be adjusted to one of four settings. Initially the blade is set in the second hole from the top. **As the blade wears it can be adjusted to one of the lower settings.**

When the 18" (457 mm) diameter coulters blade is worn to a 15 1/2" (394 mm) diameter (maximum allowable wear), it should be replaced.

Timely lubrication at the frequency indicated in the lubrication section of this manual is necessary to purge moisture and dirt from the bearing and seal. This will also lubricate the seal. Add grease until it comes out around the seal.

## SHANK POINT

If the shank point is not penetrating properly, see "Troubleshooting" to determine the cause of the problem. If replacement is necessary, be sure the shank point is installed correctly as shown below. **DO NOT ALLOW SHANK POINT TO WEAR EXCESSIVELY, NECESSITATING REPLACEMENT OF SHANK.**

(CLT22/CLT47/CLT48)

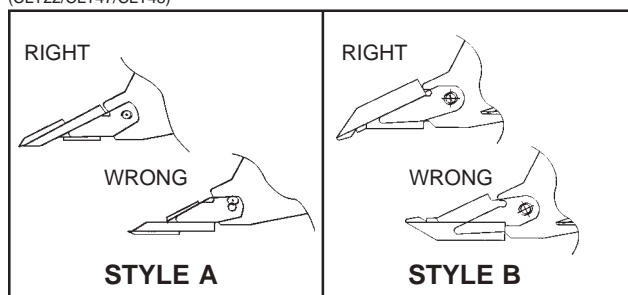

## LIQUID FERTILIZER CHAIN TENSION ADJUSTMENT

The liquid fertilizer drive chain is spring loaded and therefore self-adjusting. The only adjustment needed is to shorten the chain if wear stretches the chain and reduces spring tension. The pivot point of the idler should be checked periodically to ensure it will rotate freely.

## WHEEL BEARING LUBRICATION OR REPLACEMENT (Dual Lift Assist/Liquid Fertilizer Drive)

1. Raise tire clear of ground and remove wheel.
2. Remove double jam nuts and slide hub from spindle.
3. Remove bearings and cups and discard if bearings are being replaced. Clean hub and dry. Remove bearings only and not cups if repacking.
4. Press in new bearing cups with thickest edge facing in. (Bearing replacement procedure only.)
5. Pack bearings with heavy duty wheel bearing grease thoroughly forcing grease between roller cone and bearing cage. Also fill the space between the bearing cups in the hub with grease.
6. Place inner bearing in place.
7. Clean spindle and install hub.
8. Install outer bearing and jam nut. Tighten jam nut while rotating hub until there is some drag. This assures that all bearing surfaces are in contact. Back off jam nut 1/4 turn or until there is only slight drag when rotating the hub. Install second jam nut to lock against first.
9. Install wheel on hub and tighten evenly and securely.

PTD057(PLTR46)

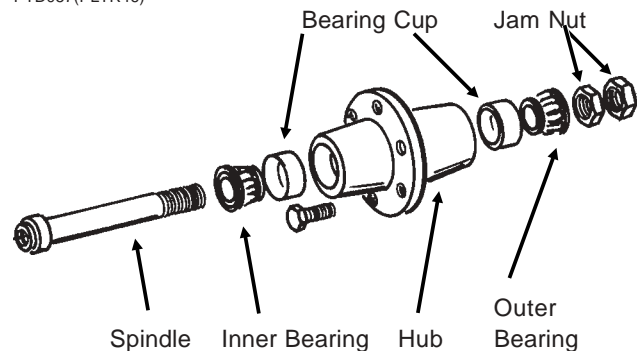

# MAINTENANCE

## WIRING DIAGRAM

(WGN66)

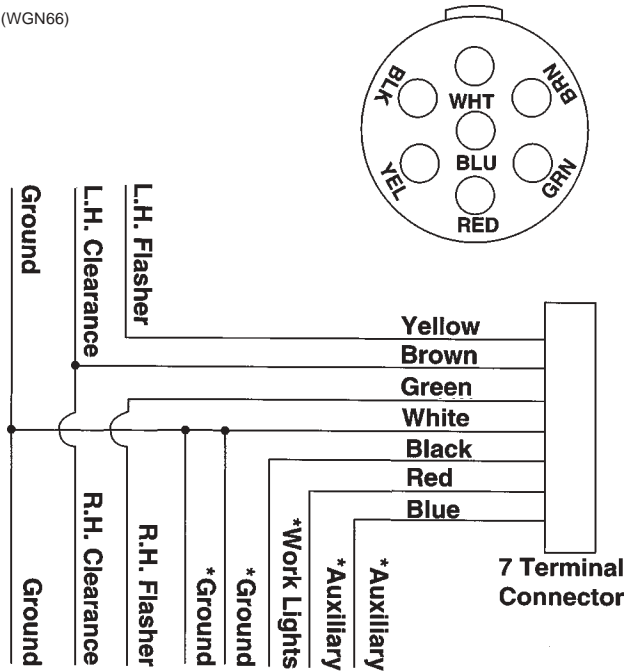

\*Optional lights and wires (to be supplied by customer) may be wired into existing plug terminals.

Light package supplied on the Model 1500 Conservation Cultivator meets ASAE standards. For the correct wiring harness to be wired into the lights on your tractor, check with the tractor manufacturer.

(CLT38)

### STYLE A Harness

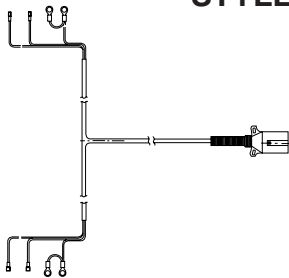

(ELC9)

### STYLE B Harness

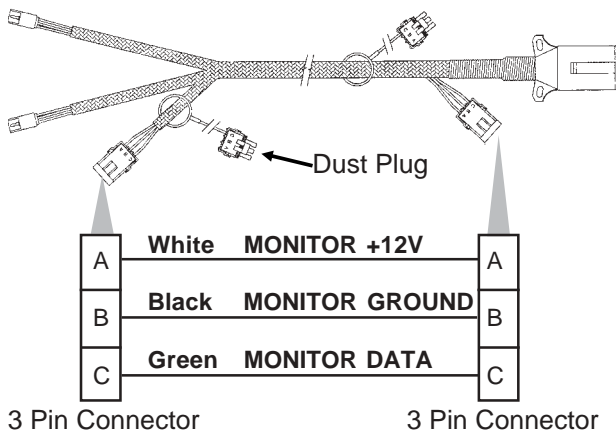

## WING FOLD CYLINDER



**DANGER:** Before applying pressure to the hydraulic system, make sure all connections are tight and hoses and fittings have not been damaged. Hydraulic fluid escaping under pressure can have sufficient force to penetrate skin causing injury or infection.

**IMPORTANT:** Always wipe hose ends to remove any dirt before connecting couplers to tractor ports.



**WARNING:** Any time a wing fold cylinder has been removed or service has been performed on the hydraulic system, be sure to charge the system by raising the wings half way up and dropping them back to level 2 or 3 times. This will charge oil into the cylinders and bleed air so restrictor will work to prevent sporadic operation of cylinders.

To remove wing fold cylinders, fold cultivator wings. Remove hoses and SAE adapters. Remove pin in barrel end of cylinder and pins in linkage with roller wheels. Remove cylinder.

## PREPARATION FOR STORAGE

Store the cultivator in a dry sheltered area if possible.

Remove all trash that may be wrapped on shares, wheels or shafts and remove dirt that can draw and hold moisture.

Clean all drive chains (If applicable) and coat with a rust preventative spray, or remove chains and submerge in oil.

Lubricate all parts as outlined in "Lubrication".

If possible, remove weight from all tires (If applicable) particularly if the unit is stored outdoors, in which case it is best to remove wheels and tires for storage in a cool dry area.

Inspect the cultivator for parts that are in need of replacement and order during the "off" season.

Store with gauge wheels off the ground.

Grease or paint shares and ridging/coulter blades to prevent rust.

See "Piston Pump Storage".

# MAINTENANCE

## LIQUID FERTILIZER PISTON PUMP/ FLOW DIVIDER

Flow to all rows should be checked periodically. If one or more lines are plugged, the desired rate will be delivered to the remaining rows keeping total application rate at desired rate.

The operator and instruction manuals shipped with the metering pump and flow divider should be kept and stored with this manual for future reference.

65909-38



## PISTON PUMP STORAGE

**KEEP AIR OUT OF PUMP!** This is the only way to prevent corrosion. Even for short periods of storage, the entrance of air into the pump, will cause **RAPID AND SEVERE CORROSION.**

### Overnight Storage

**SUSPENSION FERTILIZER** must be flushed from the pump for **ANY** storage period.

### Winter Storage

1. Flush pump thoroughly with 5 to 10 gallons of fresh water and circulate until all corrosive salts are dissolved in the pump.
2. With the pump set on 10, draw in a mixture of half diesel fuel and half 10 weight oil until the discharge is clean. Then plug inlet and outlet.

## PISTON PUMP TROUBLESHOOTING

PROBLEM	POSSIBLE CAUSE	POSSIBLE SOLUTION
Pump hard or impossible to prime.	Valves fouled or in wrong place.	Inspect and clean valves.
	Air leak in suction line.	Repair leak.
	Pump set too low.	Adjust pump setting.
	Packing washers worn out.	Replace.
Low metering.	Valves fouled or in wrong place.	Inspect and clean valves.
	Air leak in suction line.	Repair leak.
	Pump set too low.	Adjust pump setting.
	Broken valve spring.	Replace spring.
Over meters.	Broken discharge valve spring.	Replace spring.
	Trash under valves.	Inspect and clean valves.
	Improper rate setting.	Adjust pump setting.
Leaks through when stopped.	Broken discharge valve spring.	Replace spring.
	Trash under valves.	Inspect and clean valves.
Fertilizer solution leaking under stuffing box.	Packing washers worn out.	Replace.
Pump using excessive oil.	Oil seals or o-ring worn and leaking.	Replace.
Pump operates noisily.	Crankcase components worn excessively.	Inspect and replace if necessary.

## FLOW CONTROL VALVE INSPECTION

The optional dual lift assist wheels flow control valve should be adjusted as part of the assembly procedure or upon initial operation.

If the valve fails to function properly or requires frequent adjustment, the needle valve should be removed for inspection. Check for foreign material and contamination on both the valve and the seating area of the valve body. Replace any components found to be defective.

**NOTE: The flow control valve must be installed with the arrow pointed toward the cultivator.**

**NOTE: When oil is cold, hydraulics operate slowly. Make sure all adjustments are made with warm oil.**

WB001(MT2)

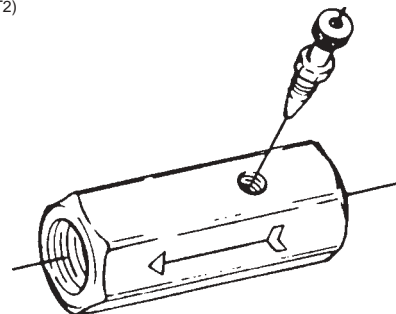

# ASSEMBLY

The Model 1500 Conservation Cultivator has been assembled as completely as possible before shipment. Set-up time should be minimal if the proper tools and equipment are used and these instructions are followed. Additional set-up time will be required to install optional equipment.

Rigid frame machines are shipped on shipping brackets as shown below. Hydraulic fold machines are shipped in the upright position with the wings locked rigid.

Before beginning assembly, read completely through these instructions. Using the contents listings at the end of this section, check to be sure you have all the parts required to complete assembly.

The information used in these instructions was current at the time of printing. Due to KINZE's continual attempt to improve its product, production changes may cause your machine to appear slightly different in detail. KINZE Manufacturing, Inc. reserves the right to change specifications or design without notice and without incurring obligation to install the same on machines previously manufactured.



**WARNING:** Never work under the cultivator while in raised position without using safety stands to safely support the machine.

(CLT21)

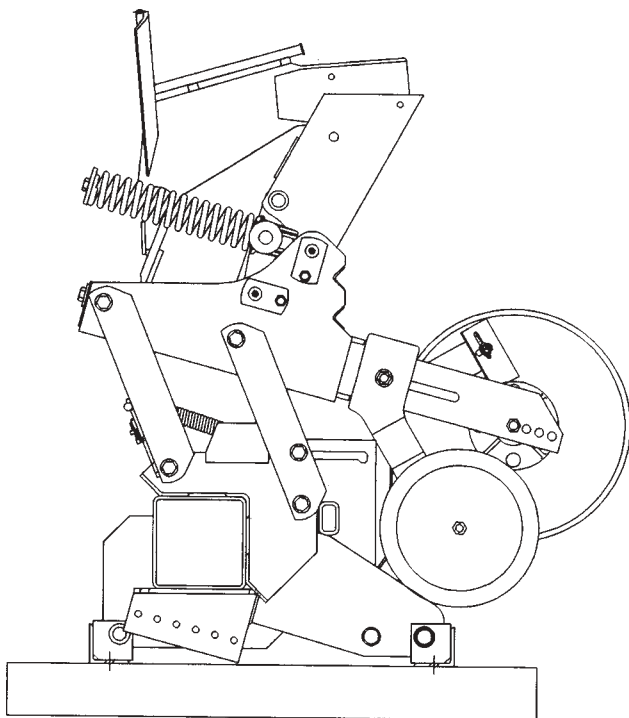

**STEP 1** (Rigid Frame Machines Only) Reposition shank assembly on each row unit from the shipping position to the operating position. (If Applicable)

(CLT6)

**3/8"-16 x 2 1/2" Cap Screw And Lock Nut**

**5/8"-16 x 2 1/2" Cap Screw And Lock Nut**

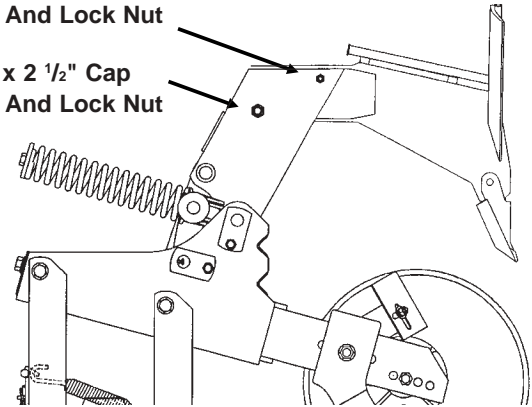

**STEP 2** (Rigid Frame Machines Only) Using a hoist or fork truck, carefully tip the cultivator toolbar upright. Check to be sure there is sufficient room before beginning this operation.

**STEP 3** While supporting the toolbar remove row unit bands.

**NOTE:** On hydraulic fold machines it will be necessary to attach the cultivator to a tractor, raise the cultivator and install safety stands. See "Operation Section".



**WARNING:** Never work under the cultivator while in raised position without using safety stands to safely support the machine.



**WARNING:** Row units are banded under tension. Use caution when removing the bands.



**DANGER:** Row units that are stuck in the up position may drop suddenly after bands are cut. Make sure all row units have dropped before working around or under the machine.

# ASSEMBLY

**STEP 4** Install desired share packages using hardware from hardware bag. End rows use only one share. **NOTE:** Share sizes are determined by the width of the share at the widest point. **FOR EXAMPLE:** 17" (432 mm) shares shown.

63758-68

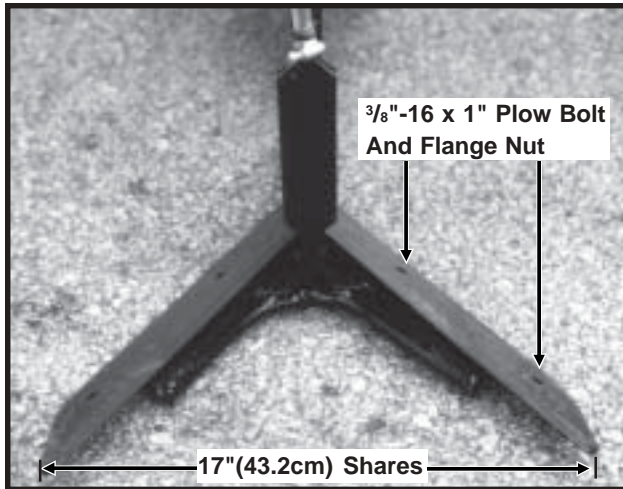

**STEP 5** Loosen the  $\frac{5}{8}$ " gauge wheel arm attachment hardware and adjust the depth gauge wheels on each row unit from the setting used for shipment to the middle range as shown. Torque to 110 ft. lbs. (149.2 N·m).

(CLT23)

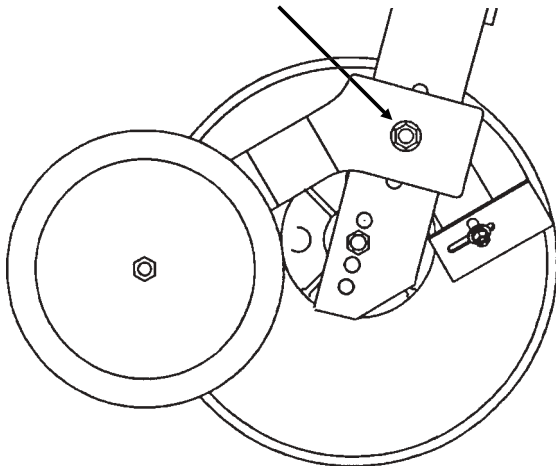

**STEP 6** Loosen and remove  $\frac{5}{8}$ " spindle bolt which attaches the 18" (457 mm) diameter coulters on each row unit and lower coulters blade to the second hole from the top as shown above. Torque to 110 ft. lbs. (149.2 N·m).

**STEP 7** (Rigid Frame Machines Only) Remove parking stand tube on each end of the machine, turn 180° and re-install.

05229817

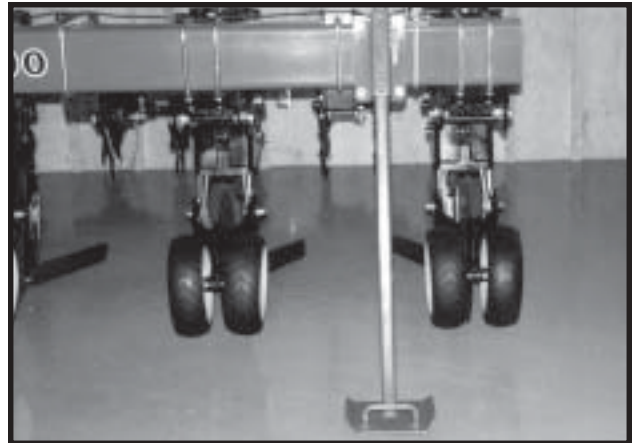

**STEP 8** (Rigid Frame Machines Only) After the toolbar has been safely supported by the parking stands, remove the center shipping bracket.

**STEP 9** All 4 row 30"/36"/38"/40", 6 row 36"/38"/40", 8 row 36"/38"/40" rigid and 8 row 36"/38" hydraulic fold cultivators are factory assembled at the 38" row spacing. If respacing is necessary, attach the cultivator to a tractor and raise the cultivator until the row units are off of the ground. **Install support stands under the cultivator toolbar to safely support the cultivator while the row units are being respaced.** Beginning at the center of the toolbar measure and mark the new spacing location for each row unit. Working out from the center of the toolbar, loosen the row unit mounting hardware and slide each row unit to the correct location and tighten hardware. It may be necessary in certain applications to move the jack stands inward to allow the row unit to be relocated. After row units are respaced, remove support stands and lower the cultivator to the ground.

**STEP 10** Refer to "Optional Attachments" for installation of cut-away weeding discs, the ridging attachment, rotary hoe/rolling disc crop shields, dual lift assist wheel package, liquid fertilizer application package, rear telescoping hitch, 6" extension for rear telescoping hitch and/or coil anhydrous shanks.

# ASSEMBLY

---

**STEP 11** Refer to the installation instruction IS224 supplied in the Auxiliary Lighting and SMV Package and IS267 supplied in the Reflector Kit (Rigid Frame Machines Only) for installation of those items.

**NOTE: A Hardware Kit is shipped with all hydraulic fold cultivators equipped with the forward toolbar. This kit is used only when the machine is equipped with rotary hoe or rolling disc crop shields. See “Assembly - Optional Attachments”.**

**STEP 12** Paint all parts scratched in shipment or assembly.

**STEP 13** Inspect assembled machine and complete predelivery/delivery check list.

# ASSEMBLY - Attachments

## Cut-Away Weeding Discs

The Cut-Away Weeding Disc Package includes one left hand and one right hand disc assembly, one clamp and two disc assembly mounts for each row unit except the end row units. The end row unit on each side of the machine will require one disc assembly mount, one disc assembly, one clamp and one 2" square tube.

Each disc assembly can be positioned to angle forward or rearward. In high trash conditions the disc assemblies should be positioned to angle rearward. Before beginning installation determine desired position.

CCU003(CLT24)

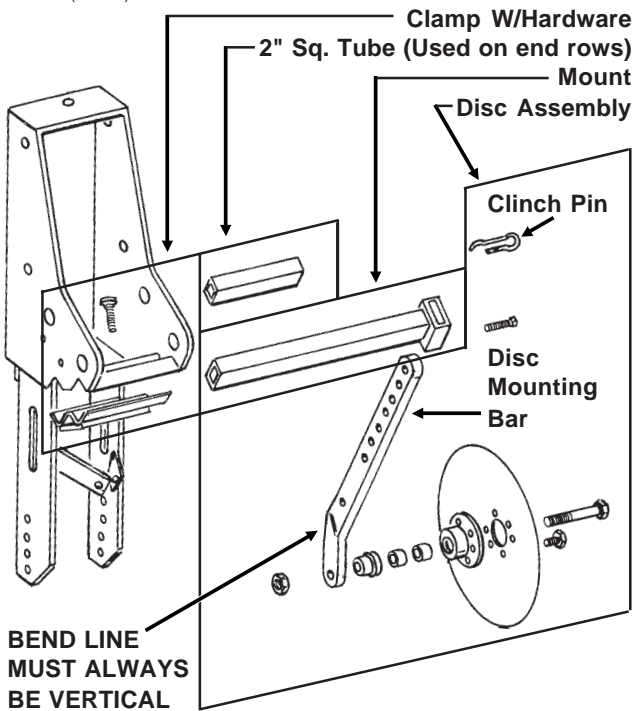

**STEP 1** Beginning on the end row unit on the left side of the cultivator, install 2" square tube and one mount using clamp. DO NOT tighten mounting hardware at this time. Remove clinch pin and slide disc assembly into mount and position in the lowest adjustment hole and secure using set screw on mount. Reinstall clinch pin in top hole.

**NOTE:** The bend line on the disc mounting bar must always be vertical and the hub/disc must be on the outer side of the mounting bar. It may be necessary to reposition the hub/disc to the opposite side of the mounting bar.

L-0129-14(CLT25)

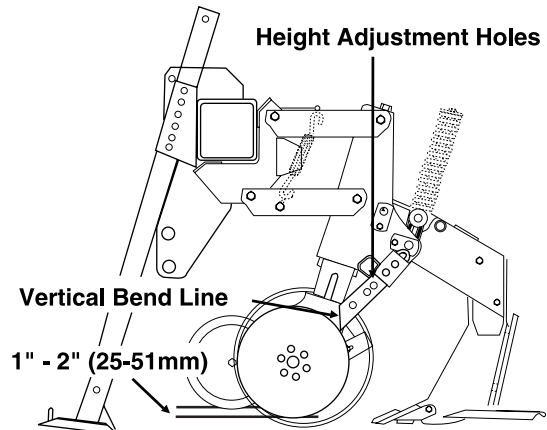

**Disc assembly positioned to angle forward**

L-0129-15(CLT26)

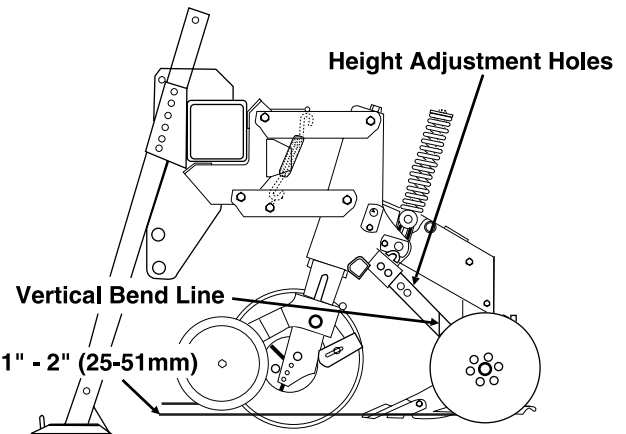

**Disc assembly positioned to angle rearward**

**STEP 2** On the end row unit on the right side of the cultivator, install 2" square tube and one mount using clamp. DO NOT tighten mounting hardware at this time. Remove clinch pin and slide disc assembly into mount and position in the lowest adjustment hole and secure using set screw on mount. Reinstall clinch pin in top hole.

**STEP 3** Install cut-away weeding discs on the rest of the row units. DO NOT tighten mounting hardware at this time.

**STEP 4** Adjust mounting tubes in or out so all rows are the same and the discs on adjacent rows are no closer than 8". Torque mounting clamp hardware to 110 ft. lbs. (149.2 N·m).

**NOTE:** Additional field adjustments may be necessary to obtain desired cutting depth and width.

# ASSEMBLY - Attachments

## Ridging Attachment

The Ridging Attachment includes a blade mount assembly with hardware for each row unit and blade bundles with blades for installation on each mount assembly as required to complete the installation. Short ridging blades are used for 30" (76.2 cm) row machines and long ridging blades for 36" - 40" (91.4 cm - 101.6 cm) row machines.

The end row unit on the left side of the machine will require one blade installed on the right side of the blade mounting assembly and the end row unit on the right side of the machine will require one blade installed on the left side of the blade mounting assembly. The rest of the row units require one blade on each side of the blade mounting assembly.

- STEP 1** Install mounting bracket onto shank on each row unit in the lowest position possible as shown. Torque  $\frac{5}{8}$ " cap screw to 110 ft. lbs. (149.2 N·m).

65909-5

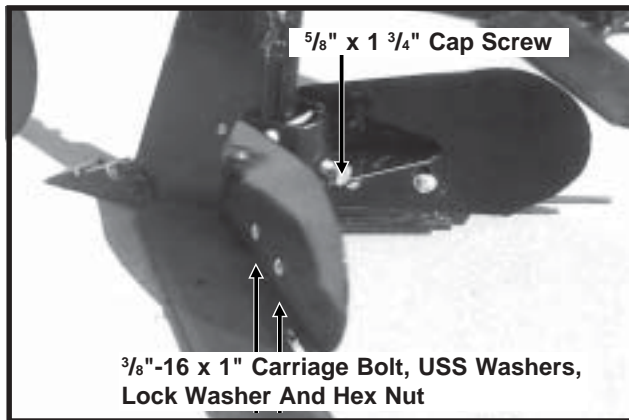

- STEP 2** Install blade(s) on to mounting bracket on each row unit even and level on the double edge share as shown above. Wide row machines require the installation of a spreader bar to maintain wing spread. Torque  $\frac{3}{8}$ " hardware to 23 ft. lbs. (31.2 N·m).

06299799

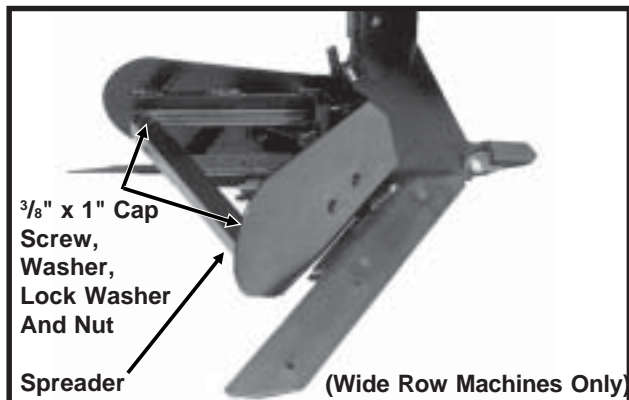

**NOTE:** Additional field adjustments may be necessary. Ridging attachment height may be varied to tailor shape and height of ridge.

## Rotary Hoe/Rolling Disc Crop Shield With Mounting Support

Crop shields are designed to be installed centered between the row units.

63749-32

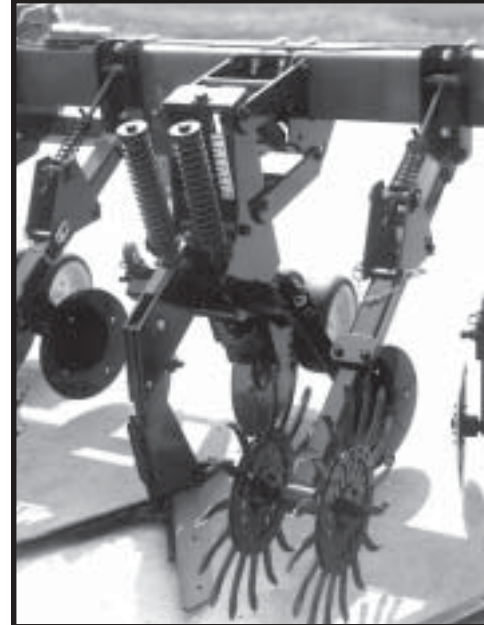

Shown With Rotary Hoe Crop Shields Installed

- STEP 1** Install crop shields onto arm assemblies using spacers as shown below.

(CLT14)

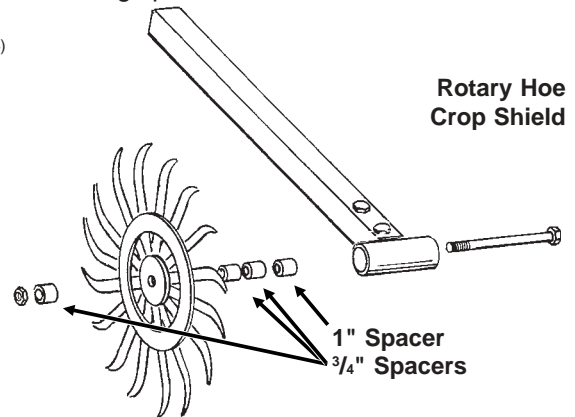

(CLT28)

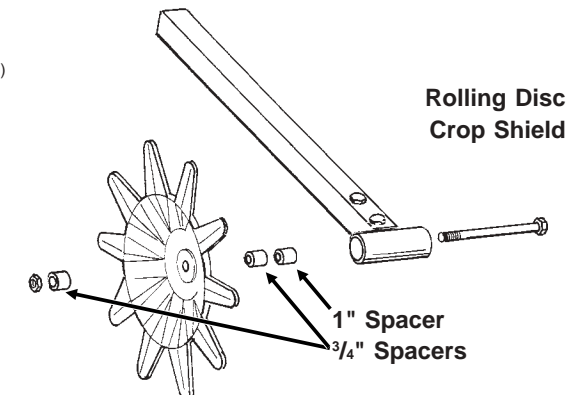

# ASSEMBLY - Attachments

**STEP 2** Install wheel/arm assembly onto mount assembly using  $\frac{1}{2}$ "-16 x  $2\frac{3}{4}$ " hardware in mount assembly.

**STEP 3** Measure and mark the center point between each row unit on the cultivator toolbar.

On some hydraulic folding machines a gusset on the toolbar will not allow installation of the mount assembly until the lower tab on the crop shield mount is cut off.

(CLT20/CLT15)

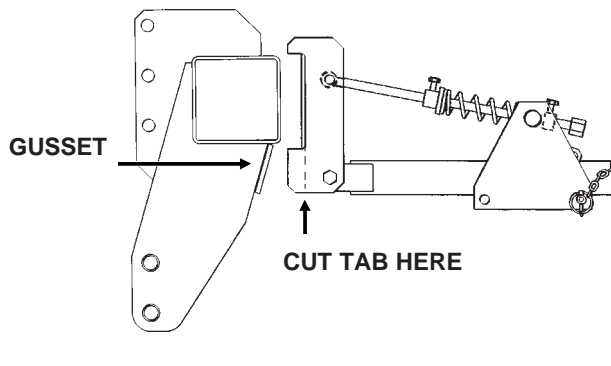

**STEP 4** Using the 7" x 7" x  $\frac{5}{8}$ "-11 U-bolt supplied with each crop shield assembly, install each unit onto the cultivator toolbar. Tighten U-bolts evenly so each unit is square with the toolbar. Torque mounting hardware to 110 ft. lbs. (149.2 N·m).

**NOTE:** A Hardware Kit is shipped with all hydraulic fold cultivators equipped with the forward toolbar. This kit is used to install the center crop shields where interference on the toolbar prevents the use of the U-bolts supplied with the crop shields.

**STEP 5** Loosen 2" x 2" U-bolt on each crop shield mounting support arm and adjust the length of the arm. Initial adjustment for 30" (76.2 cm) row machines is  $13\frac{1}{2}$ " (343 mm) between center of  $\frac{5}{8}$ " spindle and the insertion point and 18" (457 mm) for 36" - 40" (91.4 cm - 101.6 cm) row machines. Tighten U-bolts and torque to 57 ft. lbs. (77.3 N·m). Set each row the same.

A6193(CLT27)

Loosen 2" x 2" U-bolt

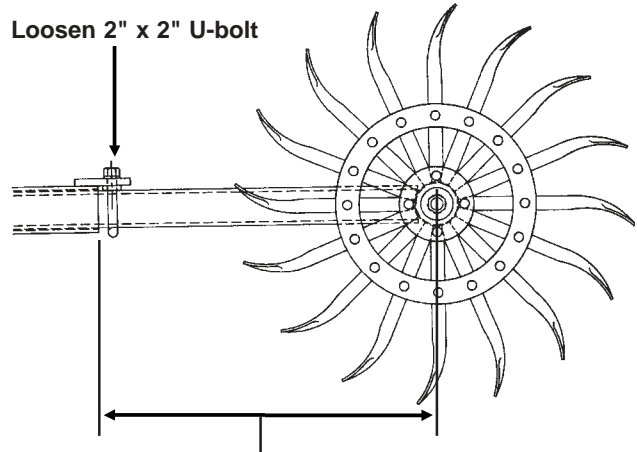

13 1/2" (343mm)/30" Row Sizes (76.2cm)

18" (457mm)/36"-40" Row Sizes (91.4cm-101.6cm)

**STEP 6** Loosen set screw on **down pressure adjustment set collar** and **depth adjustment set collar** on each row and locate each as indicated in the illustration. Tighten set screws to 112 ft. lbs. after adjustment. Adjust all rows the same.

A6193(CLT15)

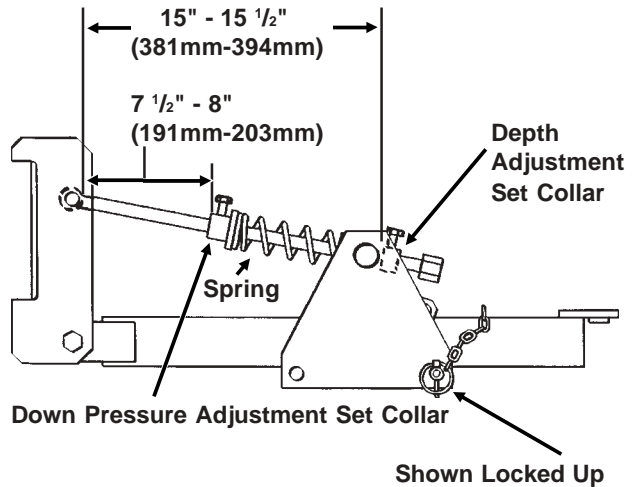

**NOTE:** Additional field adjustments may be necessary. See "Optional Rotary Hoe/Rolling Disc Crop Shield With Mounting Support" in the Operation Section for wheel width adjustment.

# ASSEMBLY - Attachments

## Liquid Fertilizer Application Equipment

The Liquid Fertilizer Application Package includes a pump assembly, flow divider, pump mount assembly, drive wheel assembly and hardware box. An optional rear telescoping hitch is available for use with the liquid fertilizer attachment for towing the liquid fertilizer supply cart (optional).

The drive wheel assembly and pump mount should be positioned in front of one of the row units.

**STEP 1** Using the following illustrations, determine location for liquid fertilizer drive wheel assembly for the applicable row size.

63749-12

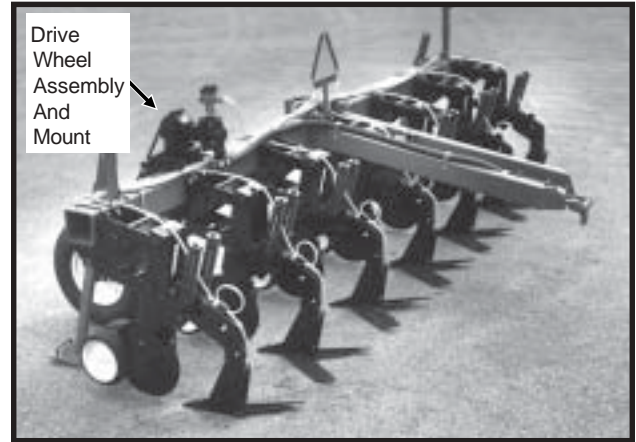

### 4 Row 30" (CLT53g/CLT63/CLT62)

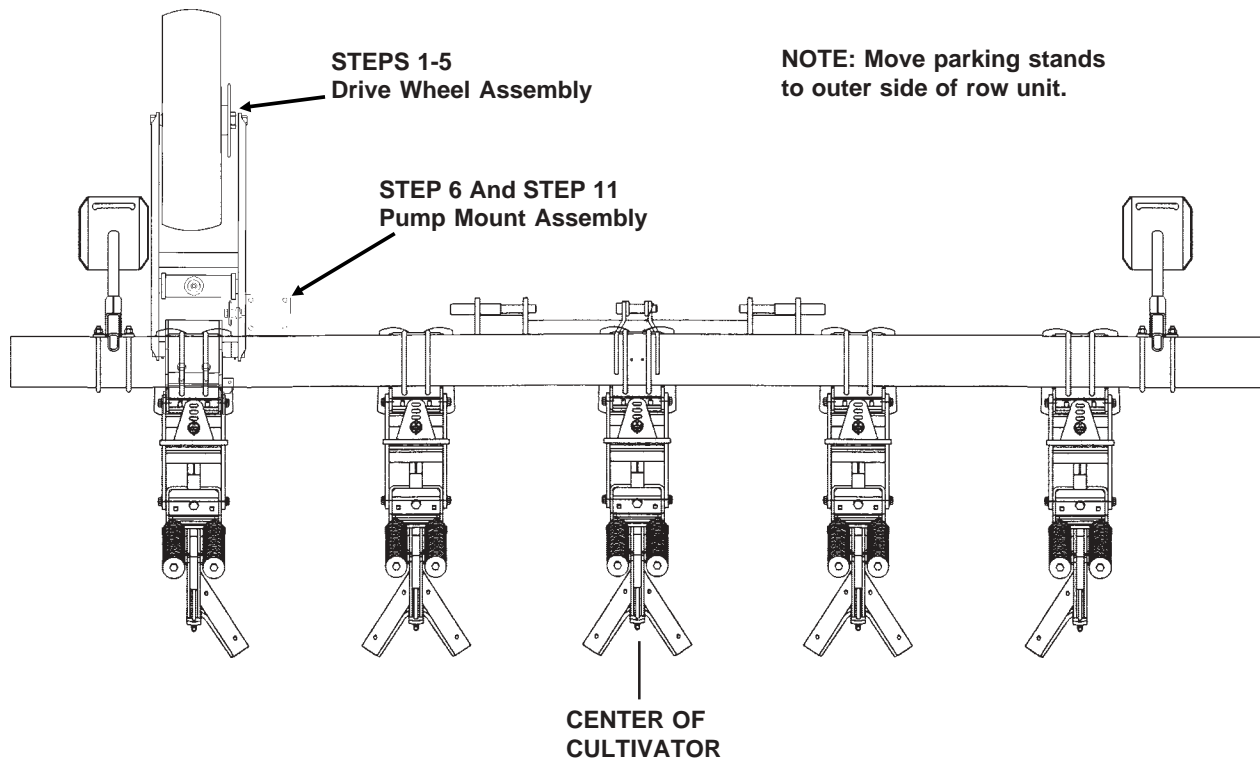

# ASSEMBLY - Attachments

## 4 Row 36"/38"/40" (CLT53h/CLT63/CLT62)

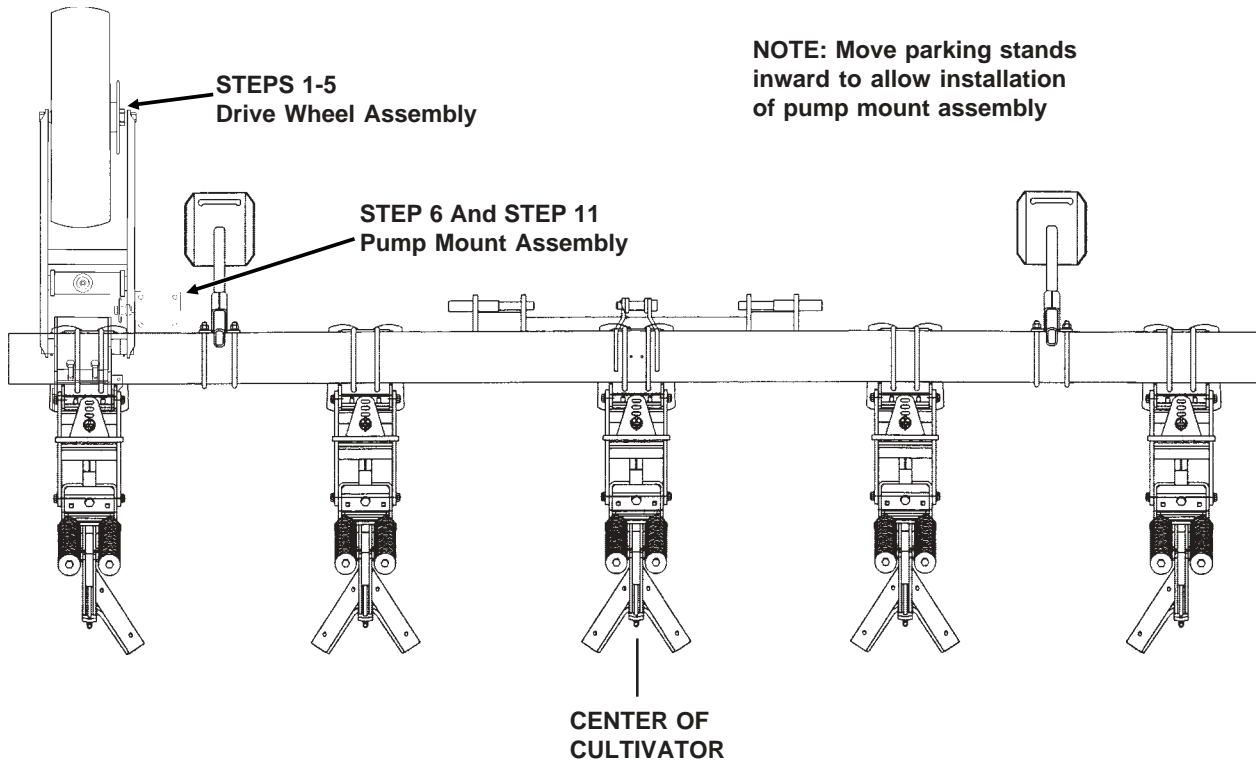

## 6 Row 30" (CLT53d/CLT63/CLT62)

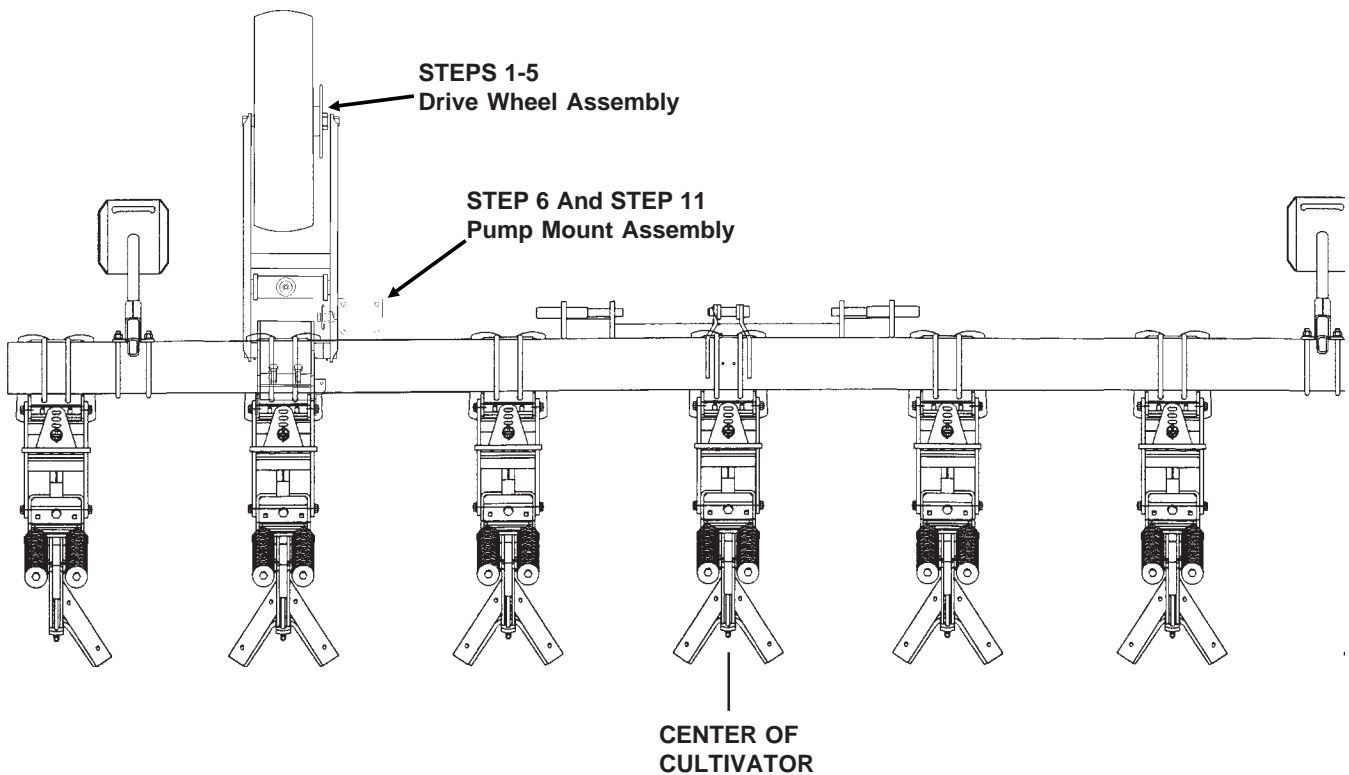

# ASSEMBLY - Attachments

6 Row 36"/38"/40" (CLT53/CLT63/CLT62)

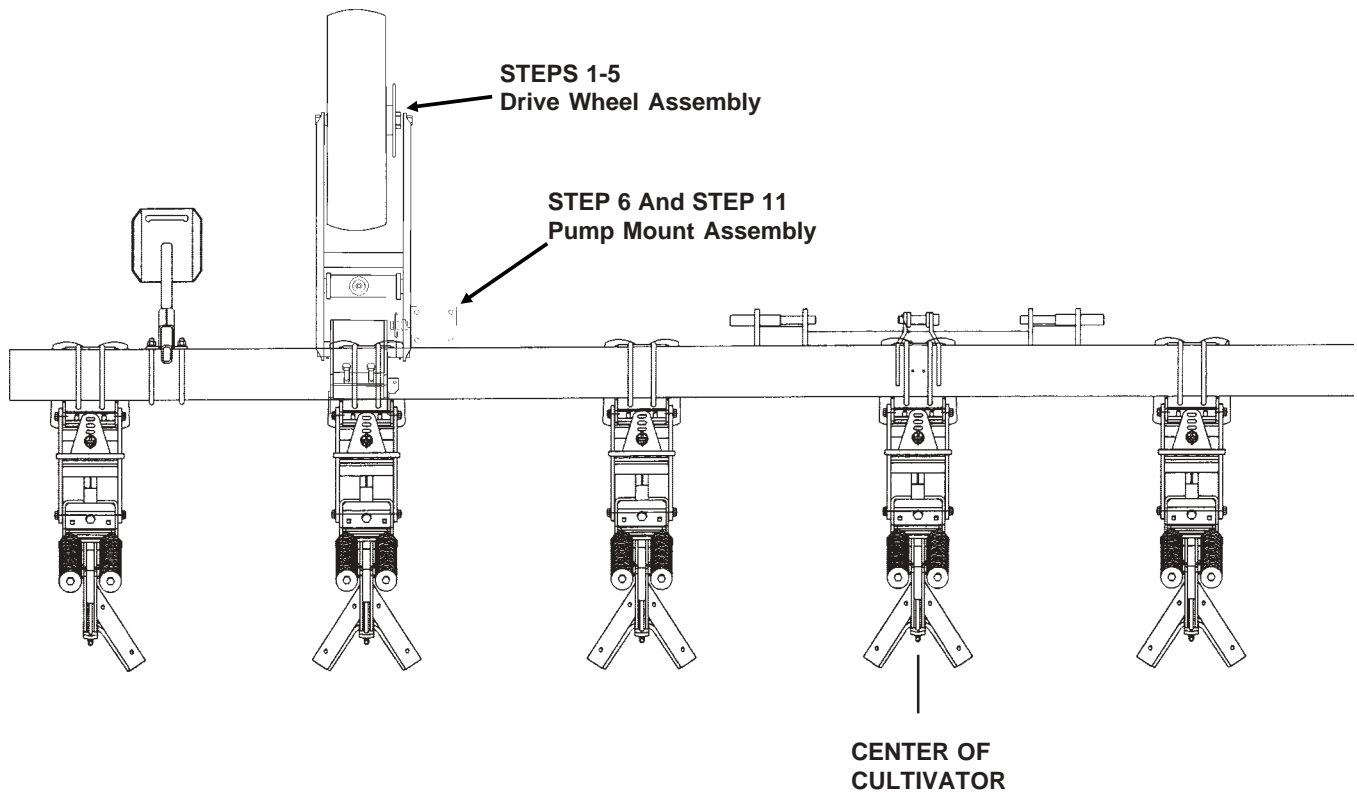

8 Row 30" (CLT53f/CLT63/CLT62/CLT64)

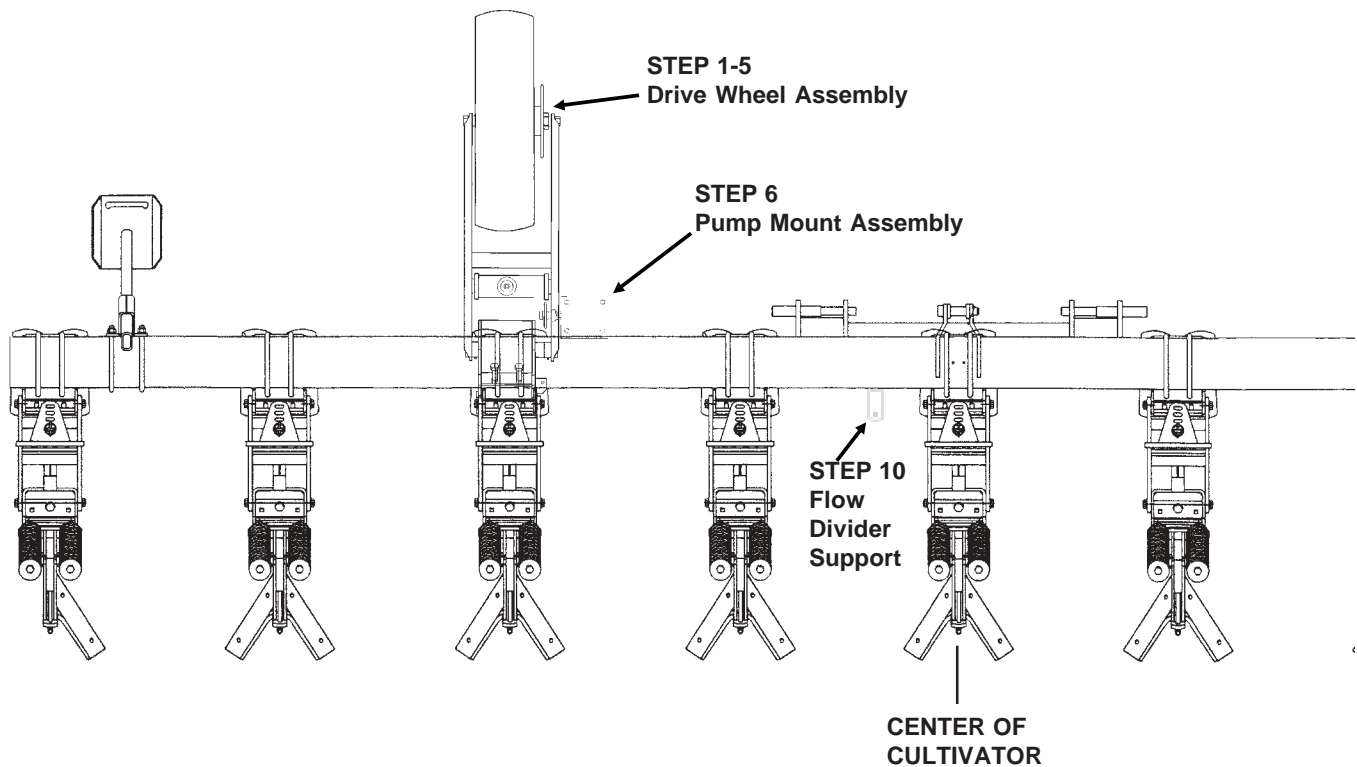

# ASSEMBLY - Attachments

8 Row 36"/38"/40" (CLT53d/CLT63/CLT62/CLT64)

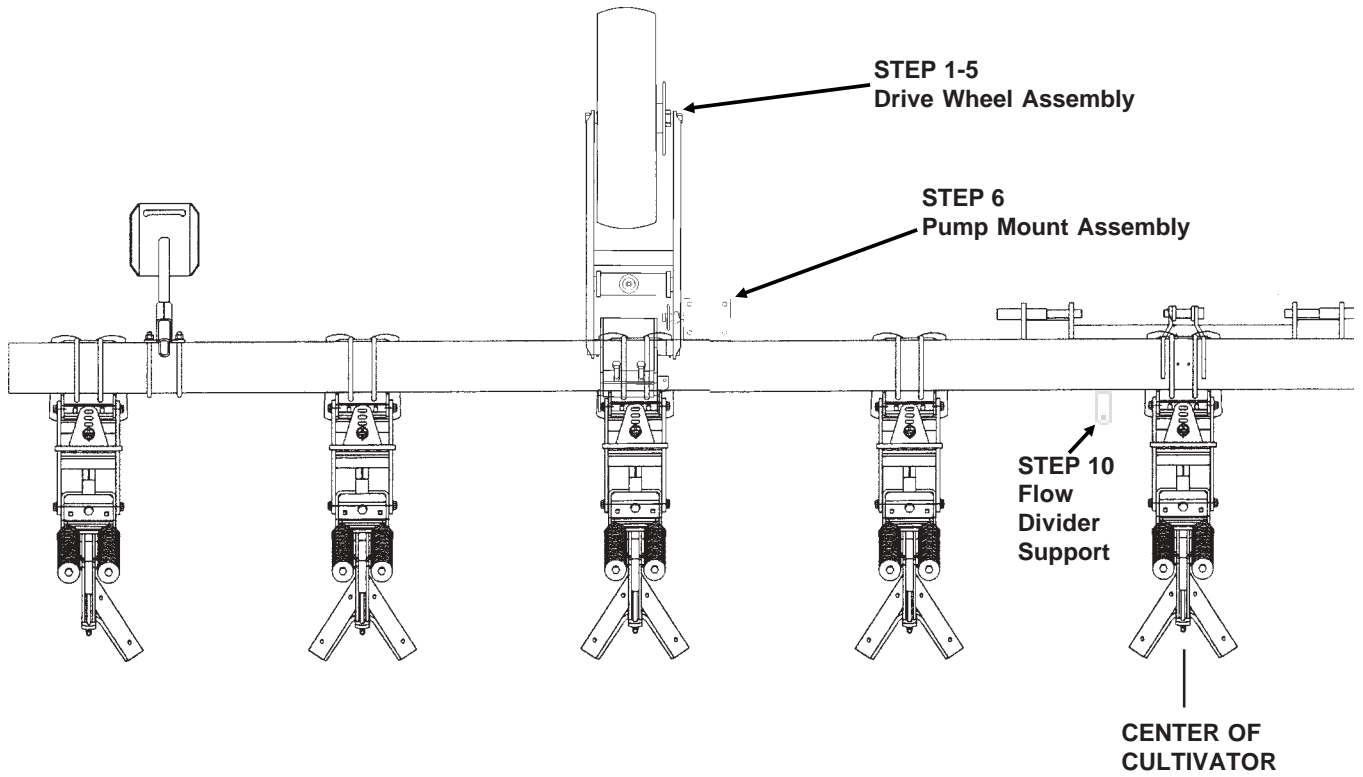

10 Row 30" (CLT53c/CLT63/CLT62/CLT64)

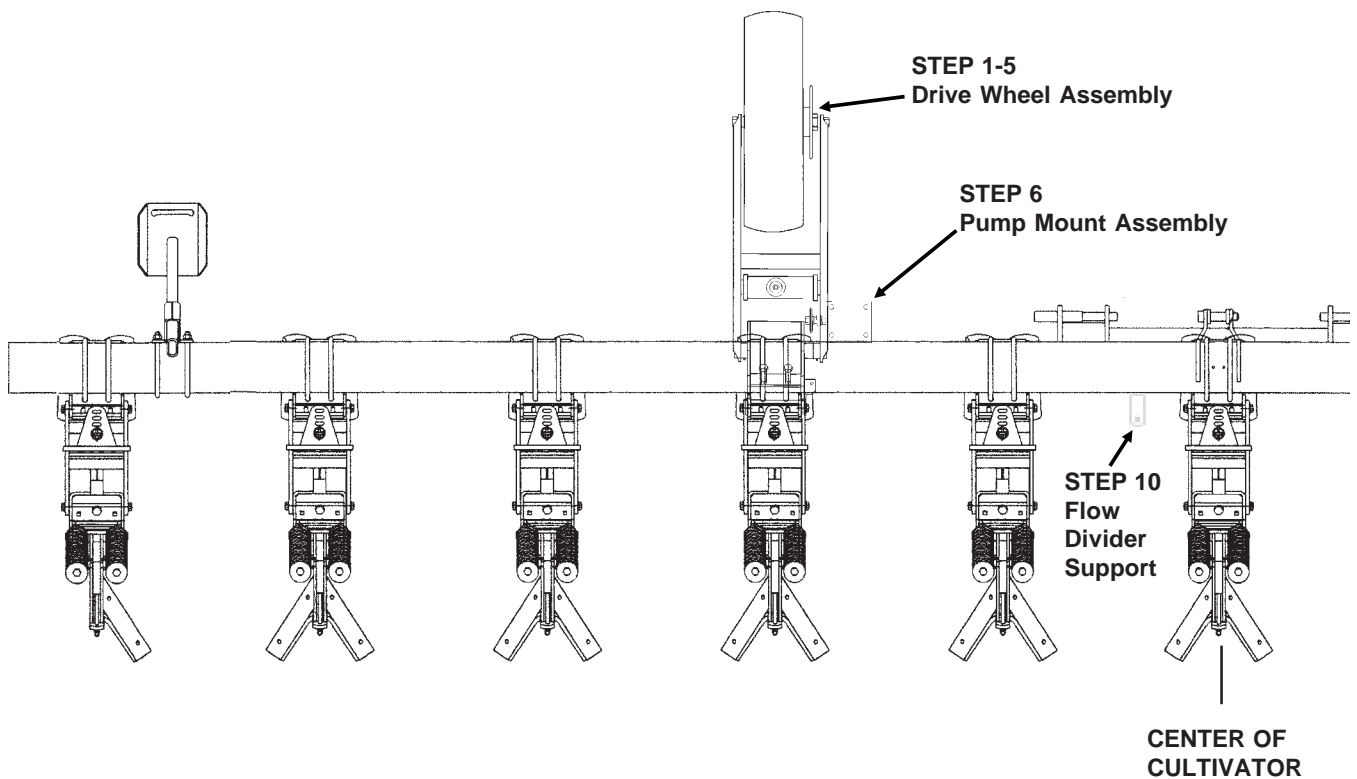

# ASSEMBLY - Attachments

## 8 Row 30" Hydraulic Fold (CLT59/CLT63/CLT62/CLT64)

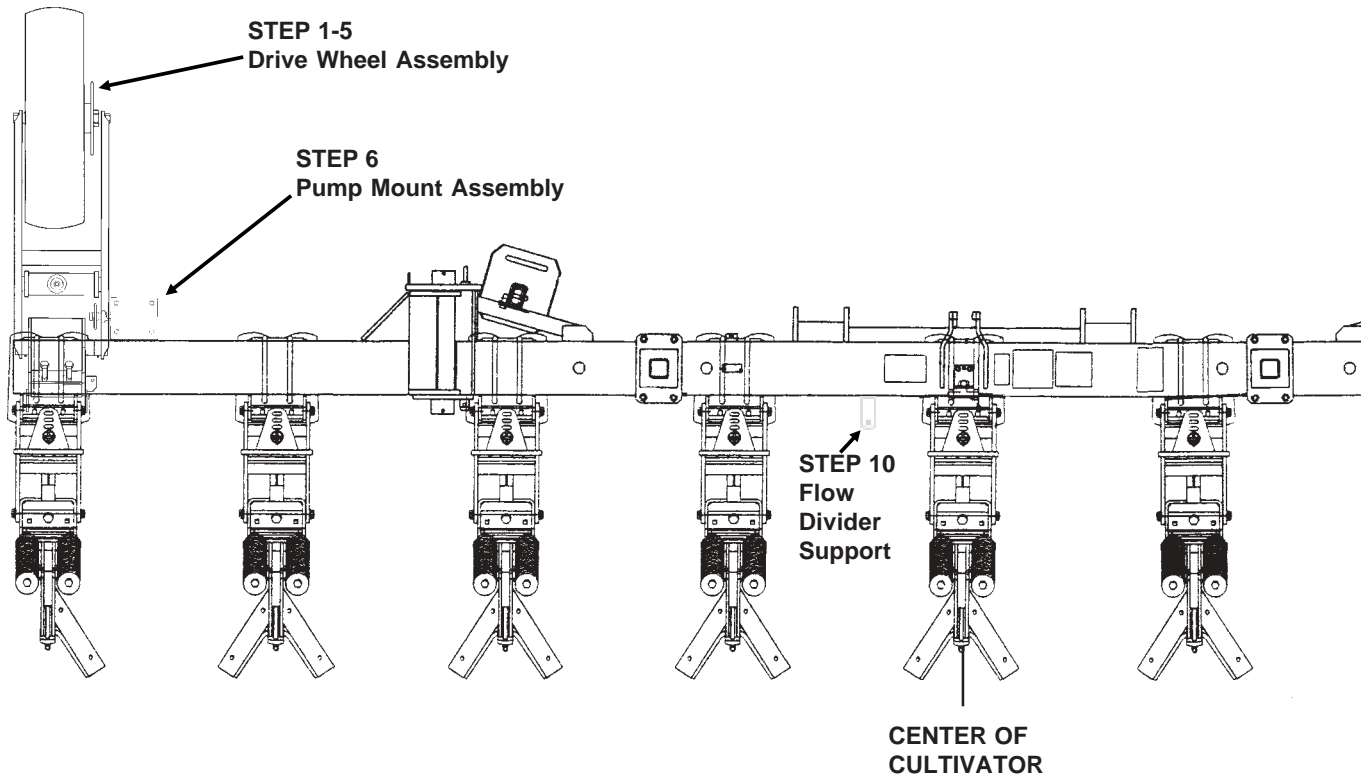

## 8 Row 36/38" Hydraulic Fold (CLT56/CLT63/CLT62/CLT64)

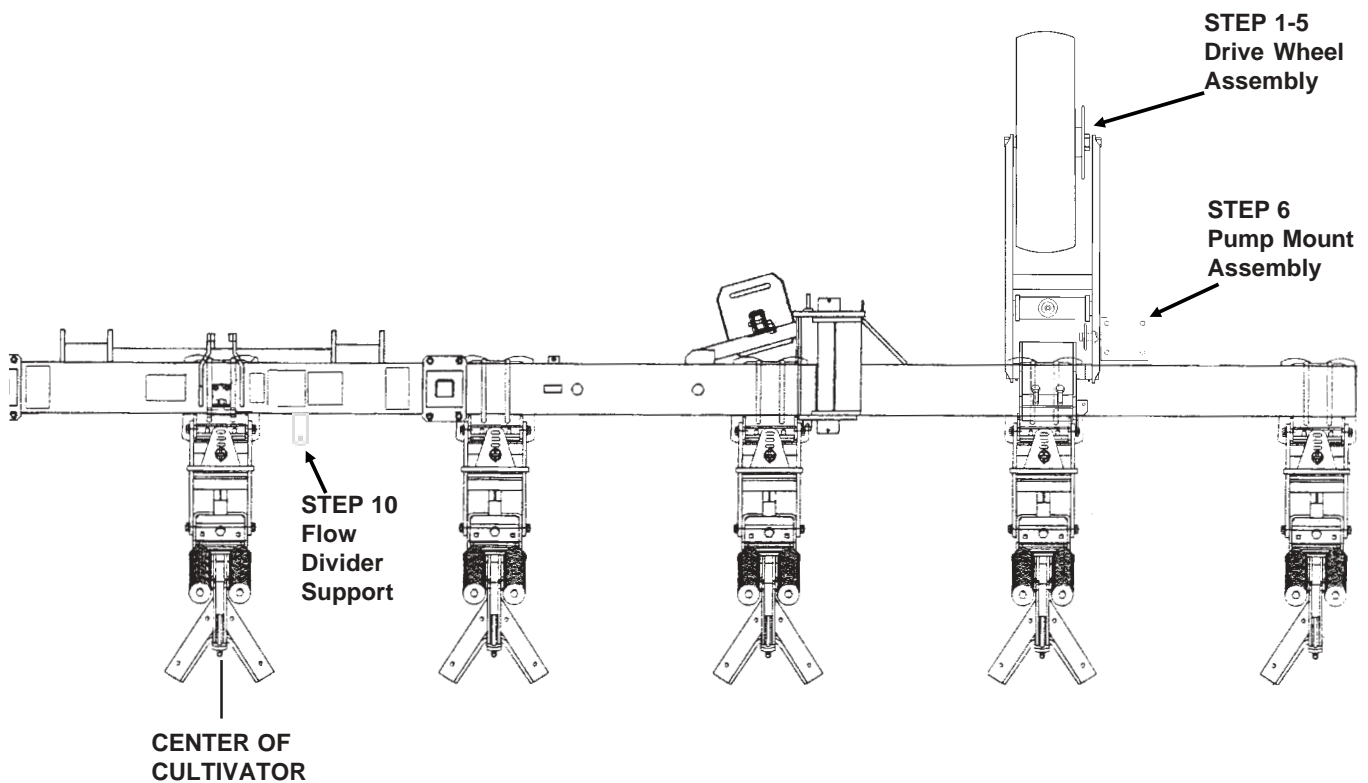

# ASSEMBLY - Attachments

## 8 Row 40" Hydraulic Fold (CLT56/CLT63/CLT62/CLT64)

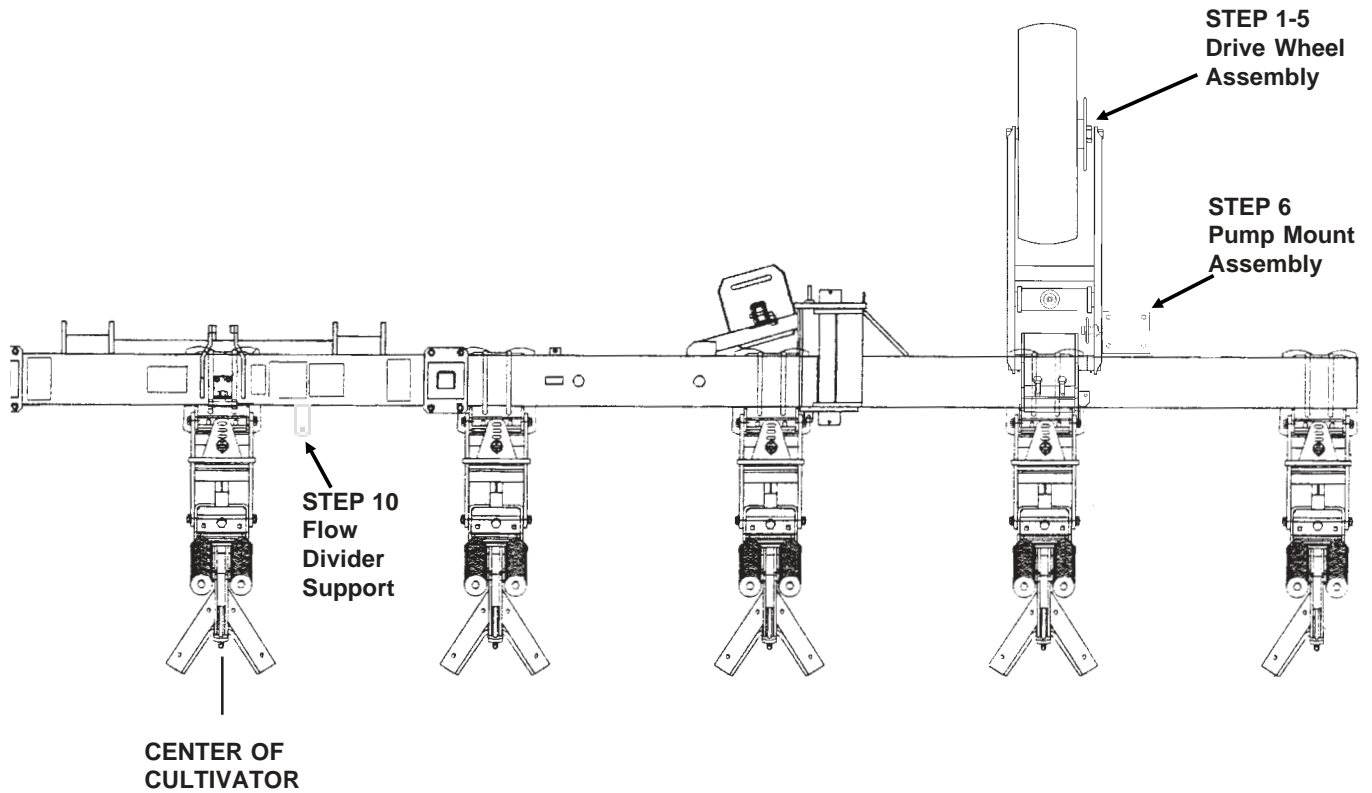

## 12 Row 30" Hydraulic Fold (CLT57b/CLT63/CLT62/CLT64)

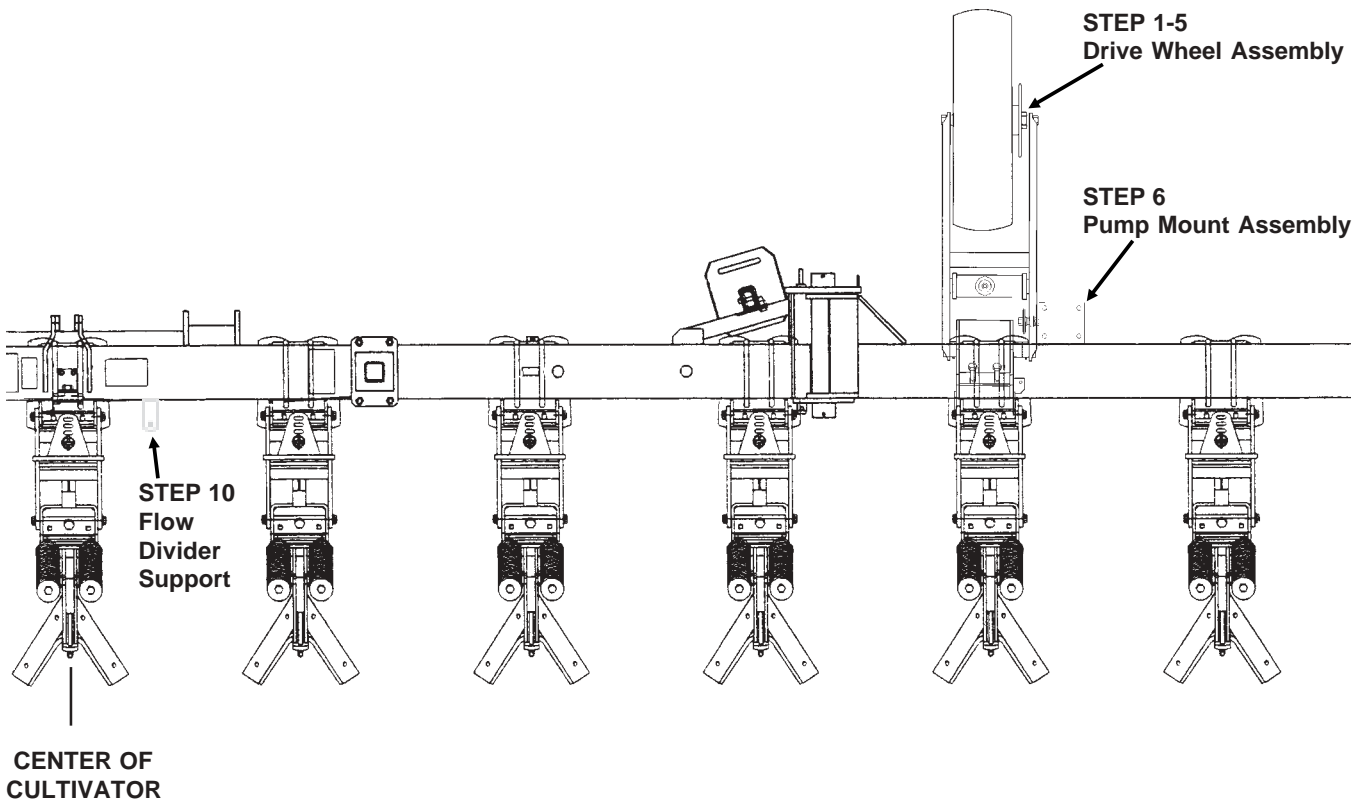

# ASSEMBLY - Attachments

## 12 Row 36" Hydraulic Fold (CLT60/CLT63/CLT62/CLT64)

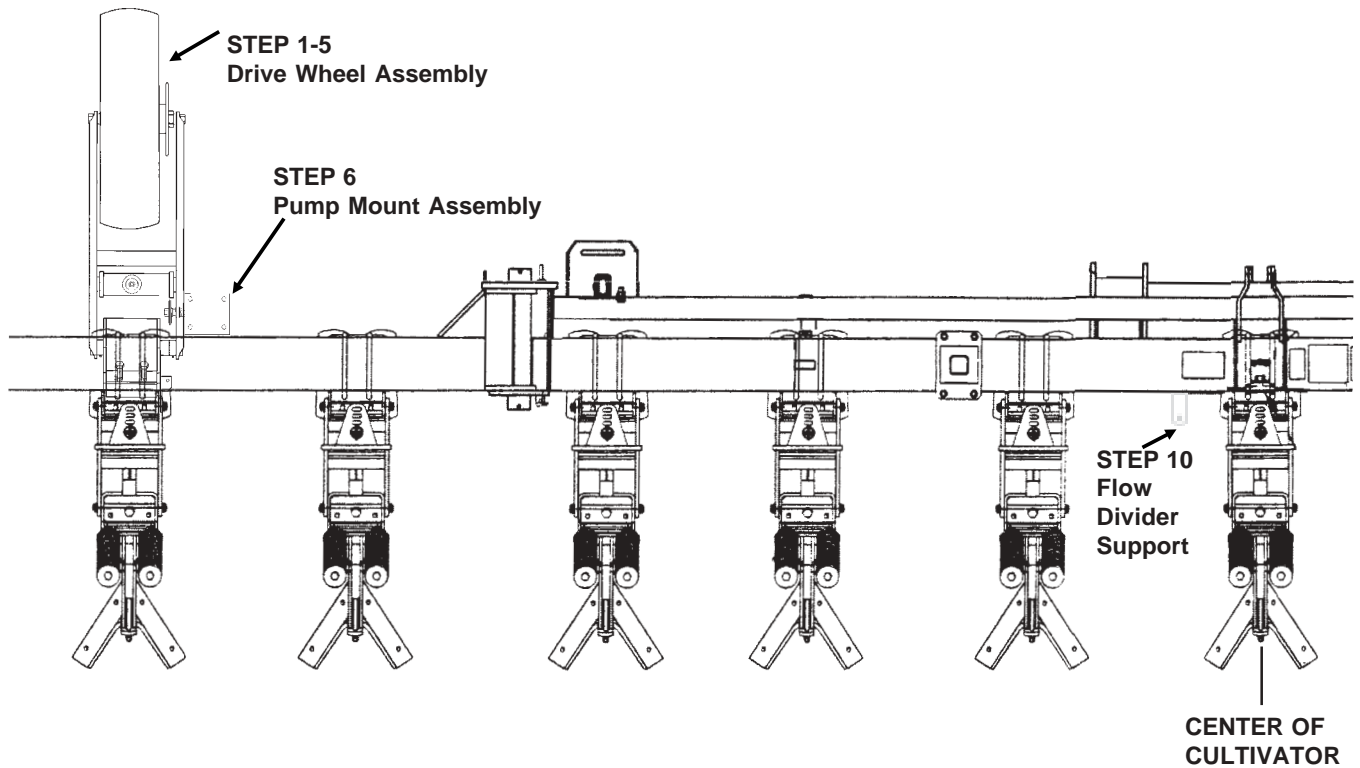

## 12 Row 38" Hydraulic Fold (CLT61/CLT63/CLT62/CLT64)

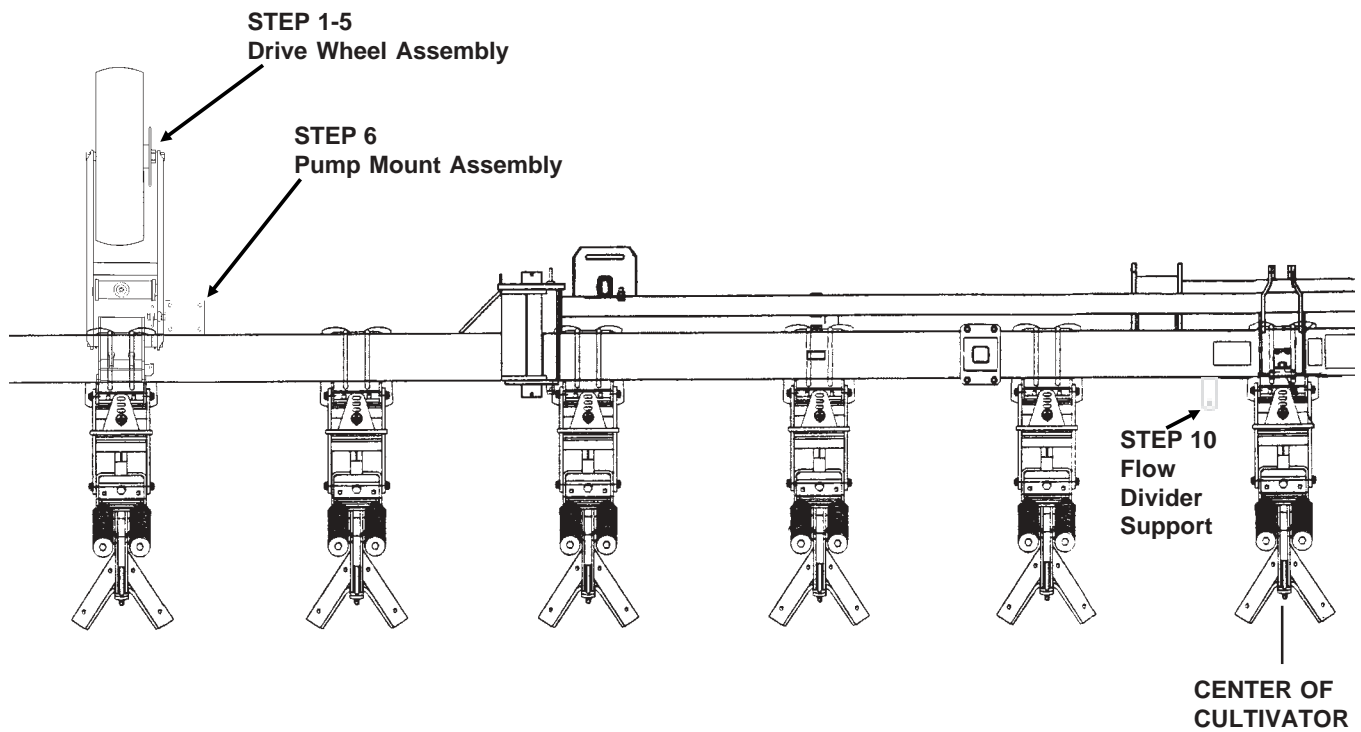

# ASSEMBLY - Attachments

## 16 Row 30" Hydraulic Fold (CLT58/CLT63/CLT62/CLT64)

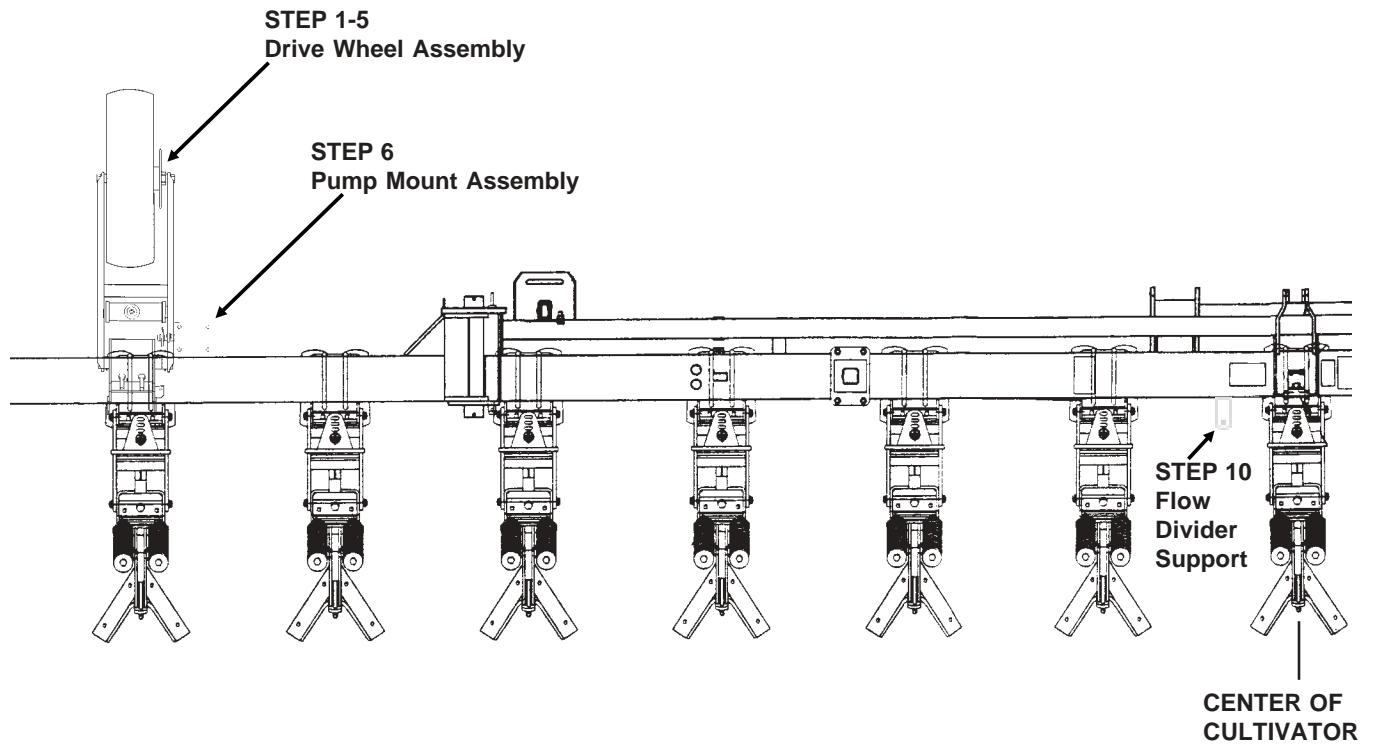

# ASSEMBLY - Attachments

**STEP 2** Remove  $\frac{5}{8}$ " parallel arm mounting bolts from upper and lower arms. Remove 7" square U-bolts from toolbar and remove mount.

(CLT29)

ROW UNIT MOUNT removed in Step 2.  
Repositioned to front side of toolbar in Step 3.

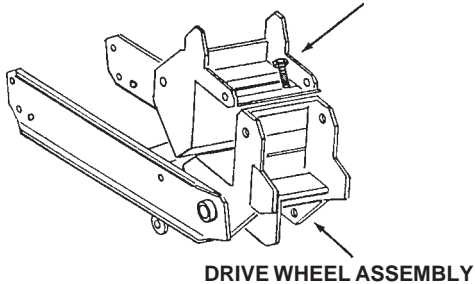

**STEP 3** Position drive wheel assembly in front of row unit. Position row unit mount removed in Step 2 to clamp the drive wheel assembly and secure using four  $\frac{5}{8}$ "-11 x 3  $\frac{1}{2}$ " cap screws, eight special washers, four lock washers and four  $\frac{5}{8}$ "-11 hex nuts supplied with the drive wheel assembly. Tighten evenly so drive wheel assembly is square on toolbar. Torque to 110 ft. lbs. (149.2 N·m).

**STEP 4** Bolt row unit parallel arms to fertilizer drive wheel assembly. Torque  $\frac{5}{8}$ " bolts to 130 ft. lbs. (176 N·m).

**STEP 5** Position upper end of spring into upper mount and secure using existing hardware and bushings. Torque to 130 ft. lbs. (176.3 N·m).

65909-41

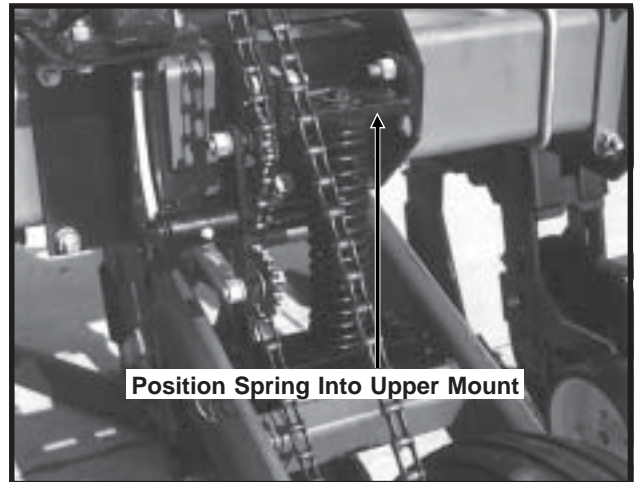

Position Spring Into Upper Mount

6 Row Shown With Installation Completed

65909-40

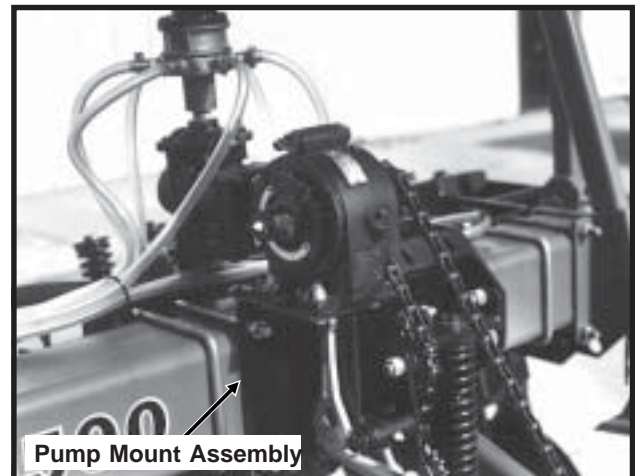

Pump Mount Assembly

6 Row Shown With Installation Completed

# ASSEMBLY - Attachments

**STEP 6** Install pump mount assembly onto toolbar, located as shown in the illustrations in Step 1, using U-bolts, lock washers and hex nuts supplied with mount. Tighten mounting U-bolts evenly so pump mount is square on toolbar. Torque to 110 ft. lbs. (149.2 N·m).

**NOTE:** Pump mount must be located so drive sprocket on pump aligns with drive sprocket on drive wheel assembly.

**NOTE:** Use pipe joint compound or teflon tape on all threaded fittings.

**STEP 7** Install reducing bushing and 1 1/4" elbow onto bottom of piston pump as shown below.

**STEP 8** Install pump assembly onto pump mount using 3/8" hardware supplied with pump. Place one flat washer onto 3/8" bolt. Install bolt from the bottom up through the pump mount. Install another flat washer, one mounting pad, and another flat washer between the pump and pump mount. Secure bolt on the top side using a lock washer and hex nut.

**NOTE:** On 4 and 6 row machines the flow divider is installed directly above the piston pump. On 8 through 16 row machines the flow divider is remote mounted as close to the center of the machine as possible.

**STEP 9** Remove plug from top port on pump and install 3/4" fitting from hardware bag as shown below.

**STEP 10** (8-16 Row Machines Only) Locate flow divider support as close to the center of the machine as possible and install using 7" x 7" x 3/4" U-bolt, lock washers and hex nuts. Install hose barbs, 3/4" hose, hose clamps, elbow and reducing bushing (16 Row Only) between piston pump and flow divider support.

**STEP 11** Install flow divider.

CCU006/CCU007(CLT30/CLT31/INS135a)

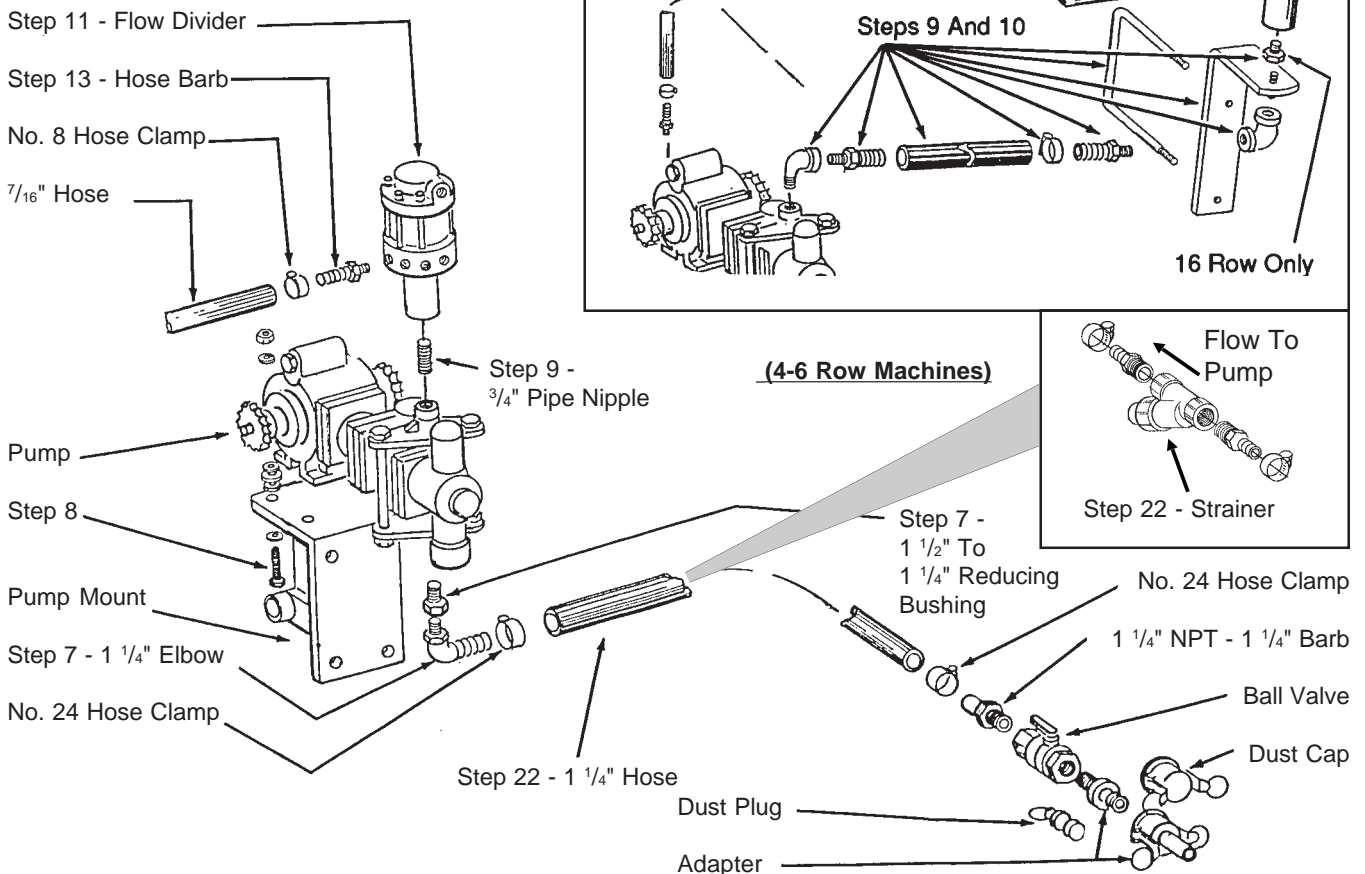

# ASSEMBLY - Attachments

**STEP 12** (Hydraulic Fold Machines Only) Remove vent plug from front of piston pump and install hose barb and 24" piece of  $\frac{7}{16}$ " hose. Loop 24" hose rearward over piston pump to prevent leakage from the piston pump when the wing is folded. Secure with tie strap.

12139601

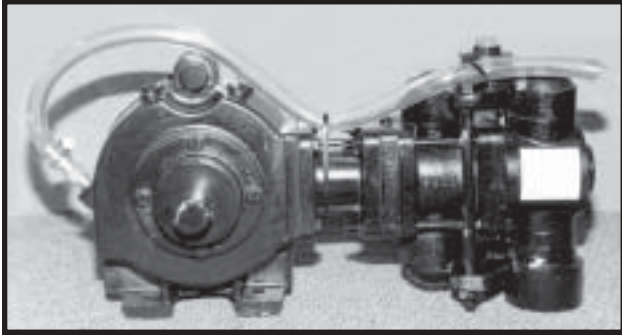

**STEP 13** Install an even number of hose barsbs in flow divider opposite each other to ensure longest life of divider. Plug unused ports. Plug unused ports.

For example, on a 6 row cultivator install barsbs in ports 1, 2, 3, 7, 8 and 9 as shown below in the top view of a flow divider. (Arrow heads indicate fitting installed in port.)

(CLT32)

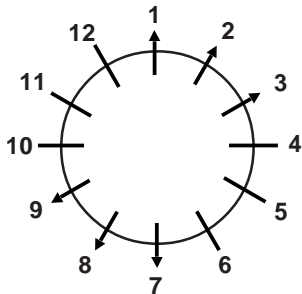

TOP VIEW OF FLOW DIVIDER

**STEP 14** Remove plugs and install hose barsbs in fertilizer tubes on rear of shanks.

(CLT33)

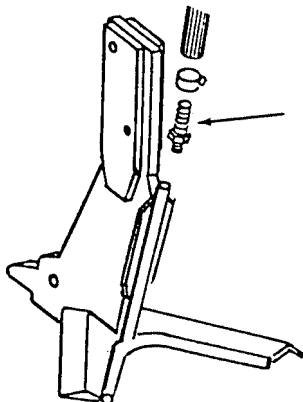

**STEP 15** The end row units have only one discharge spout while the other row units have two discharge spouts. Therefore, one  $\frac{7}{16}$ " hose from the flow divider must be routed to the center of the cultivator, the hose cut and a tee fitting installed. Route one hose from the tee fitting to the end row on the R.H. side of the cultivator and one hose from the tee fitting to the end row on the L.H. side of the cultivator.

**NOTE:** Making a loop in the hose just above the shank will reduce the dribbling effect when pump stops while turning on ends. A hole is provided in the top of the shank to secure the hose loop with tie straps provided.

Route and install hoses from flow divider to fertilizer tubes on rest of row units. The hoses do not need to be equal in length, however the shortest hose should be no less than half the length of the longest hose.

65909-60b

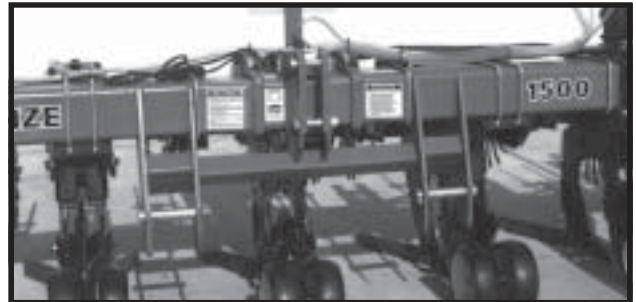

70723-5

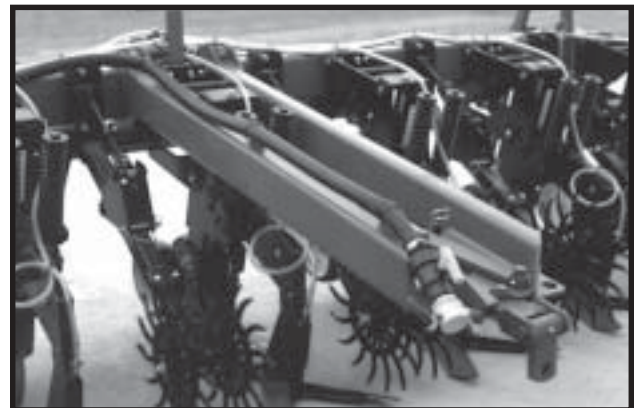

# ASSEMBLY - Attachments

65909-36



**STEP 16** Secure hoses to toolbar with tie straps supplied in liquid fertilizer package.

**STEP 17** Install drive chain on drive wheel assembly routing around idler sprockets as shown in photo in Step 5.

**STEP 18** Attach idler tension spring between idler and mounting bracket.

**STEP 19** Store adjustment wrench as shown.

65909-38

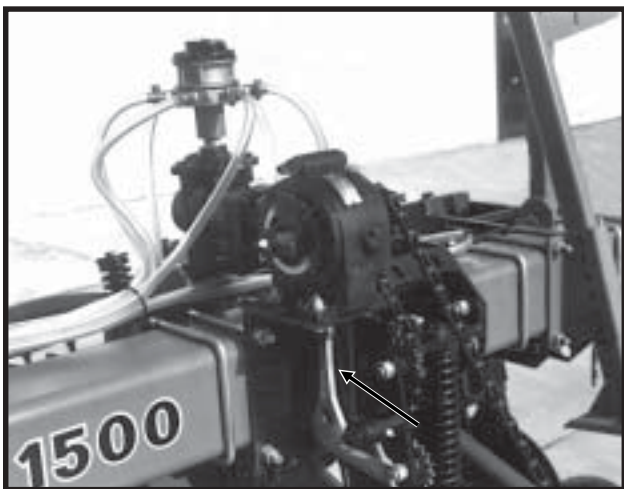

**STEP 20** Check chain alignment and align if necessary.

**STEP 21** (If Applicable) Install "Rear Telescoping Hitch (Toolbar or Dual Lift Assist Wheel Mounted)" as instructed on that page.

73593-25



**Dual Lift Assist Wheel Mounted Rear Telescoping Hitch Shown**

**STEP 22** Install 1 1/4" hose and fittings as shown on previous page. Route 1 1/4" hose toward center of toolbar and along rear telescoping hitch (If Applicable). Install strainer located between piston pump (As close to piston pump as possible.) and ball valve using two 1 1/4" barb fittings and No. 24 hose clamps as shown on page 9-7. Install ball valve and fittings. Secure using tie straps.

70723-6

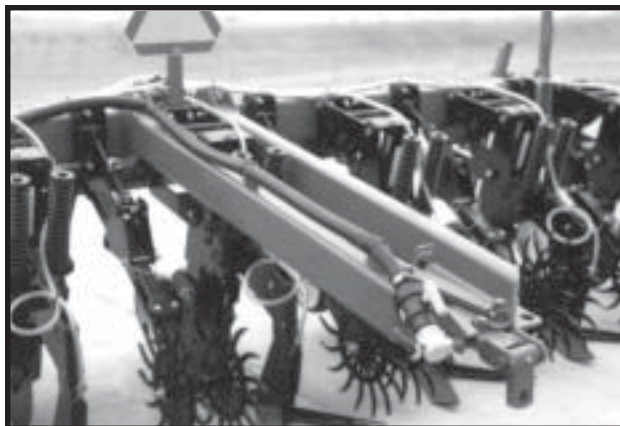

**Toolbar Mounted Rear Telescoping Hitch Shown**

**CAUTION:** It is important after the package has been installed to inspect to be sure the tractor will clear the liquid fertilizer drive wheel when the wings on hydraulic fold machines are folded.

# ASSEMBLY - Attachments

## Dual Lift Assist Wheel Package

The Dual Lift Assist Wheel Package includes two lift assist wheel assemblies with mounting hardware, hydraulic cylinders, hoses and fittings.

Lift assist wheel assemblies are usually installed located to match the tractor tire track. Sufficient hose length is supplied to allow installation at the widest width.

**NOTE:** Dual lift assist wheel equipped machines require use of *three point quick-hitch or guidance system three point hitch*. When using lift assist wheels the top link pin in the cultivator hitch mast is not used.

70691-23



**STEP 1** Determine locations for lift assist wheel assemblies.

(CLT55)

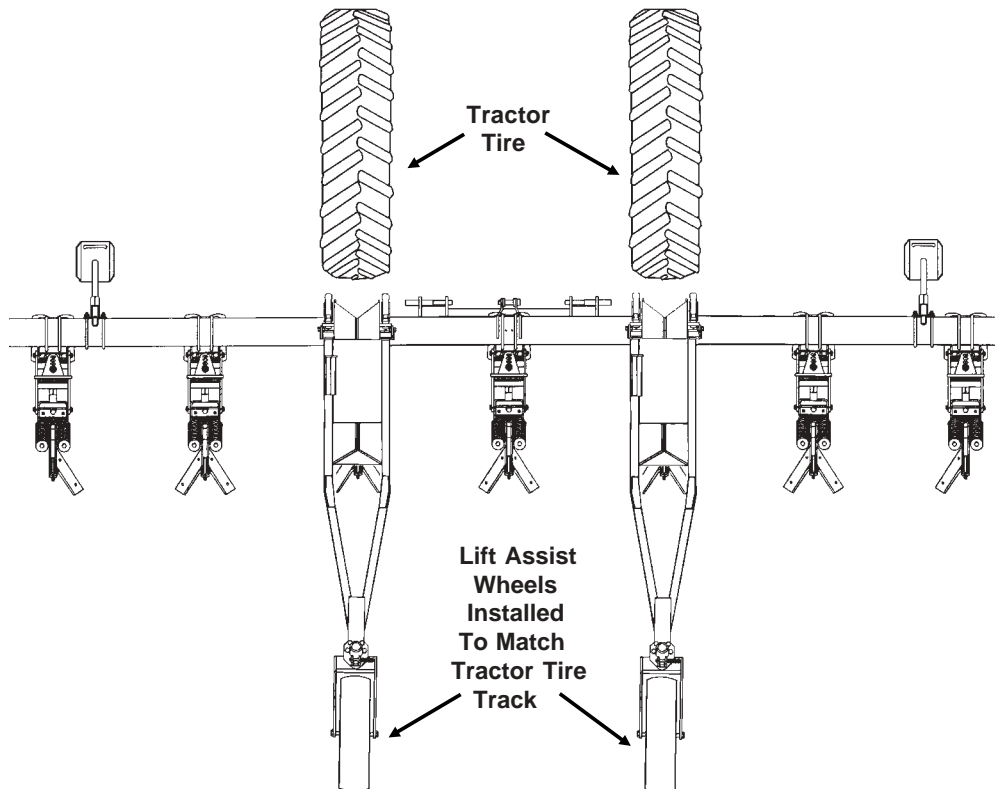

**STEP 2** Install on rear side of cultivator frame straddling the row unit as shown in the photo at left. Secure using 1"-8 x 3" cap screws and square nuts. Tighten bolts evenly to ensure the assembly draws up square to the frame Torque cap screws to 675 ft. lbs. (915.3 N-m).

**STEP 3** Position cylinder on each lift assist wheel assembly as shown in the illustration on the following page with ports to the top side and connect base end and rod end of cylinder to lift assist wheel assembly. Use the center of the three holes for initial setup.

**STEP 4** Install hoses, flow control valve (If Applicable) and fittings as shown in the illustration on the following page. Run the hoses along the frame following wing lift hose routing. Use pipe compound on pipe threads only. Threads on o-ring and flared fittings do not require any thread treatment. Secure hoses with tie straps.



**DANGER:** Before applying pressure to the hydraulic system, make sure all connections are tight and that hoses and fittings have not been damaged. Hydraulic fluid escaping under pressure can have sufficient force to penetrate skin causing injury or infection.

**STEP 5** Field test and adjust the unit. Adjustment holes on the lift assist cylinder mount.

# ASSEMBLY - Attachments

CCU008/HTA014/PLA015(CLT34a/CLT34b)

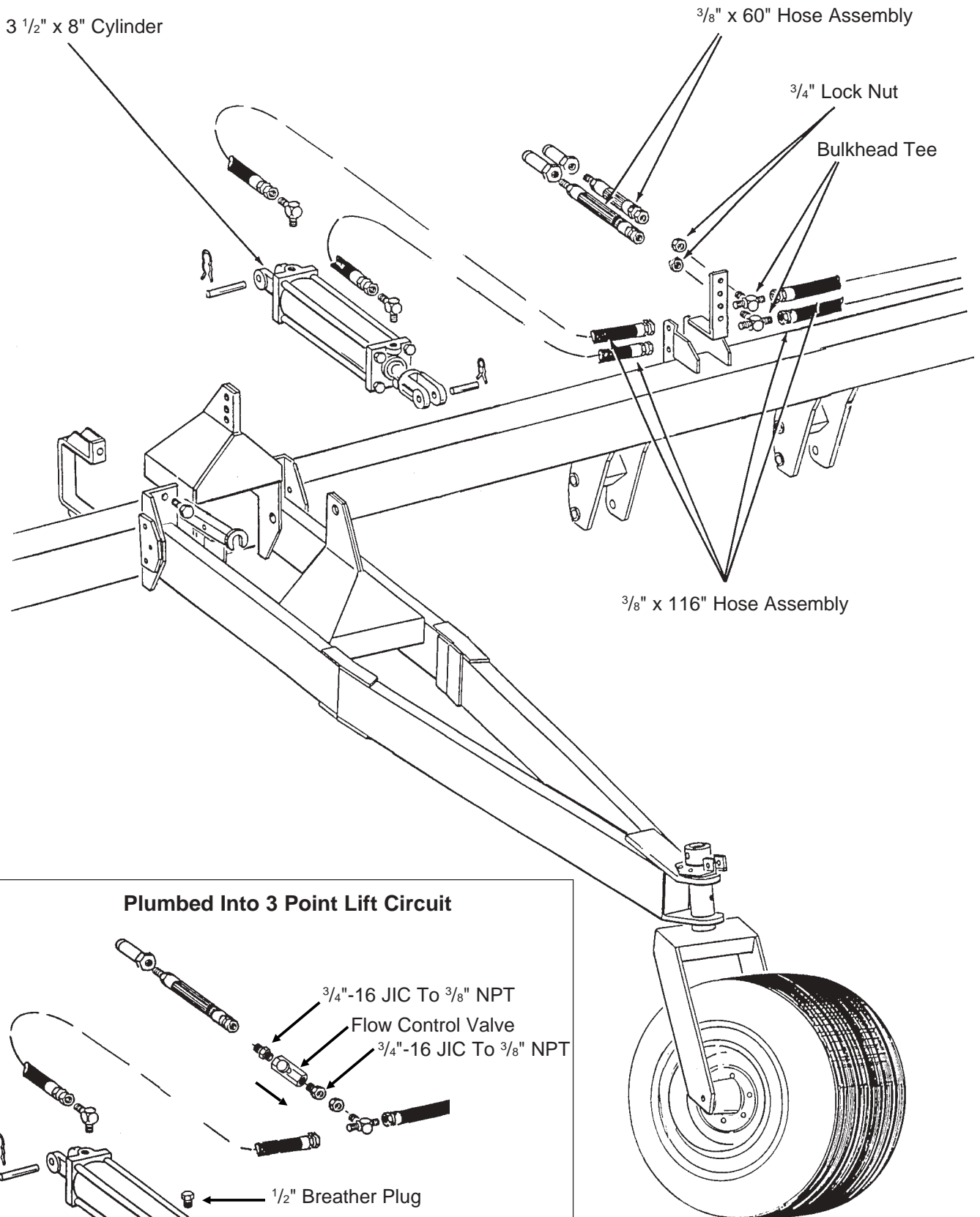

# ASSEMBLY - Attachments

## Coil Anhydrous Shank With Knife Mount

Each Coil Anhydrous Shank With Knife Mount Package includes one coil shank with mounts, spacers and hardware to install the shank onto the row unit. The knife is not included.

The coil anhydrous shank can be used with or without the row unit shank installed.

**STEP 1** Raise the cultivator so the row unit shank clears the ground and install safety stands under the cultivator frame to safely support the machine during installation of the coil anhydrous shanks.



**WARNING:** Never work under the cultivator while in raised position without using safety stands to safely support the machine.

**STEP 2** Remove  $\frac{3}{8}$ "-16 x 2  $\frac{1}{2}$ "-16 and  $\frac{5}{8}$ "-11 x 2  $\frac{1}{2}$ " row unit shank mounting hardware and install mounts as shown using  $\frac{3}{8}$ " x 3  $\frac{1}{2}$ " and  $\frac{5}{8}$ "-11 x 3  $\frac{1}{2}$ " cap screw and lock nuts. Tighten bolts evenly so mounts are square on unit. Torque  $\frac{3}{8}$ " bolts to 23 ft. lbs. and  $\frac{5}{8}$ " bolts to 110 ft. lbs.

**NOTE:** If row unit shank is not being used remove it at this time. Be sure to install a 1" spacer (customer-supplied).

CCU009(CLT35)

**STEP 3** Install  $\frac{1}{2}$ "-13 x 2" cap screw through hole in coil shank and secure with lock nut.

**STEP 4** Install coil shank between the two mounts as shown using two spacers and four  $\frac{1}{2}$ "-13 x 3  $\frac{1}{4}$ " cap screws and lock nuts. Six holes in each mount and spacer allow for a choice of two installation locations. Tighten bolts evenly so coil shank is square on the unit. Torque bolts to 57 ft. lbs. The  $\frac{1}{2}$ "-13 cap screw installed through the coil shank in Step 3 prevents the loss of the coil shank should it become loose in the mount.

**STEP 5** Install knife mounting plates onto coil shank using four  $\frac{1}{2}$ "-13 x 2  $\frac{3}{4}$ " cap screws and lock nuts. Tighten bolts evenly and torque to 57 ft. lbs.

**STEP 6** Install customer-supplied knife using two  $\frac{1}{2}$ "-13 x 2" cap screws and lock nuts. Two adjustment locations are available.

**STEP 7** Repeat Steps 2 through 6 to install coil shanks on other row units.

See "Operation Section" for additional information.

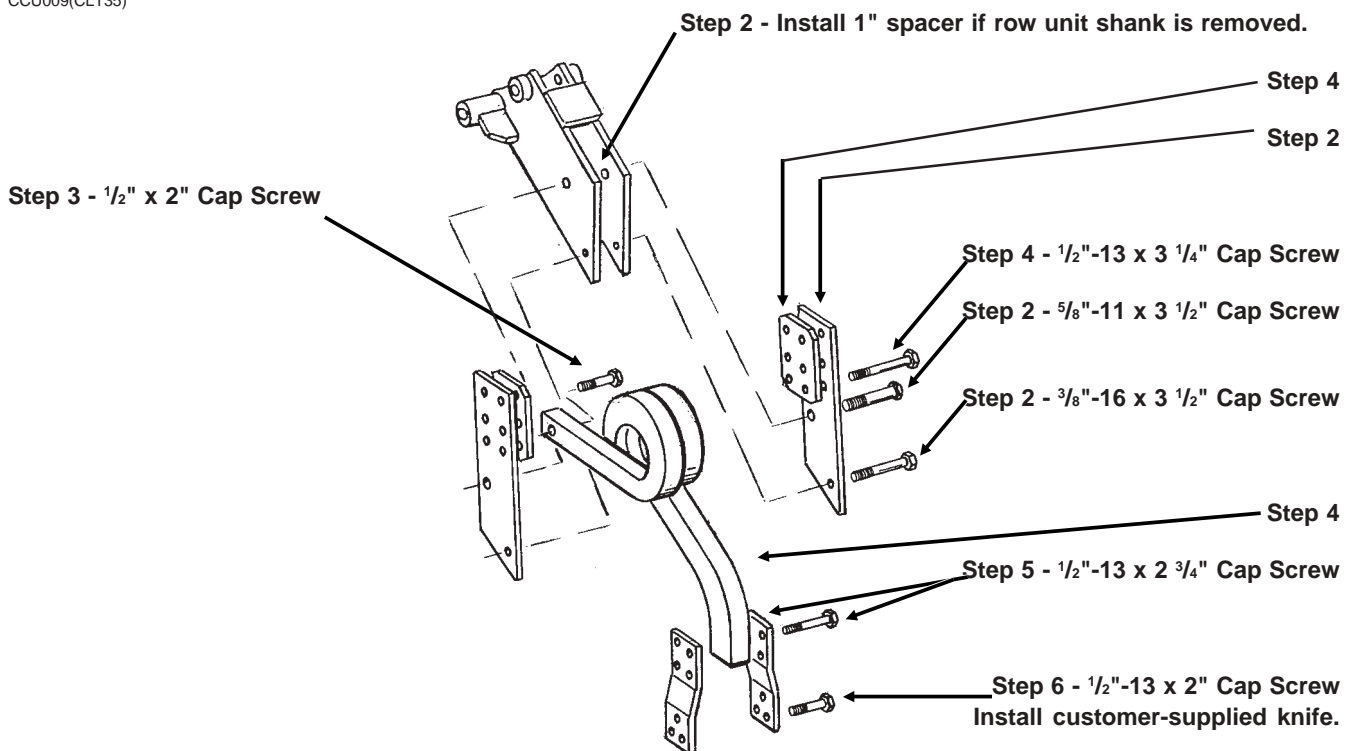

# ASSEMBLY - Attachments

## Rear Telescoping Hitch And 6" Hitch Extension

The Rear Telescoping Hitch is designed for use with the Liquid Fertilizer Application Package or Coil Anhydrous Shank Package. It is available in two configurations, toolbar mounted or dual lift assist wheel mounted.

**NOTE: The 6" Hitch Extension Package must be used with the toolbar mounted rear telescoping hitch when using the coil anhydrous shank on the center row unit to allow clearance for the cultivator shank mechanism to operate.**

### TOOLBAR MOUNTED REAR TELESCOPING HITCH INSTALLATION

Install toolbar mounted rear telescoping hitch at center of cultivator frame. Tighten 1"-8 installation bolts evenly so hitch is square on frame. Torque cap screws to 675 ft. lbs. (915.3 N·m).

(CLT18D)

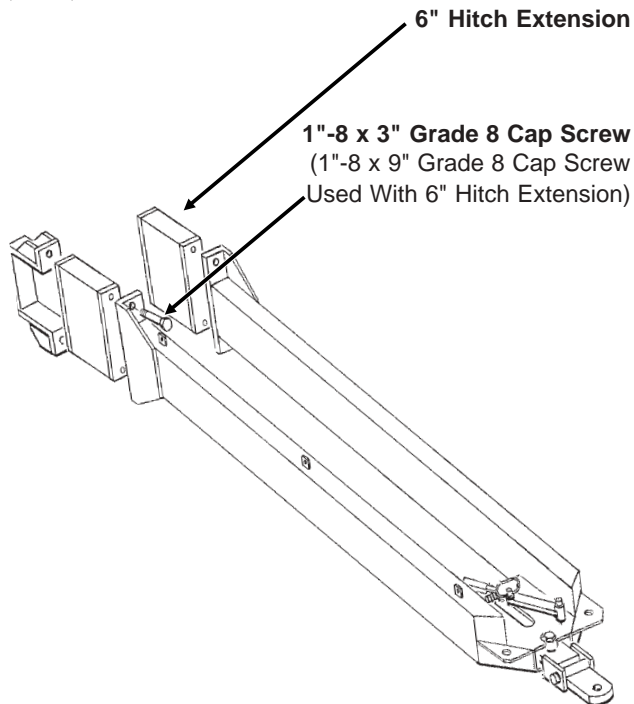

### DUAL LIFT ASSIST WHEEL MOUNTED REAR TELESCOPING HITCH INSTALLATION

Install rear telescoping hitch centered between the dual lift assist wheels.

1. Loosen 4" x 6" x 5/8"-11 U-bolts and remove mounting plates from rear telescoping hitch assembly.
2. Using 6" x 2" x 5/8"-11 U-bolts, lock washers and hex nuts, install mounting plates onto dual lift assist wheels as far to the rear as possible as shown below.
3. Position rear telescoping hitch onto mounting plates. Center hitch between dual lift assist wheels. Secure using 4" x 6" x 5/8"-11 U-bolts, lock washers and hex nuts.
4. Torque 5/8"-11 bolts to 110 ft. lbs. (149.2 N·m).

73593-25



12 Row Wide Shown

**NOTE: U-bolts may be installed as close as 1/2" to the end of the telescoping 4" x 6" hitch mounting bar.**

# ASSEMBLY - Contents Listing

<b>Rigid Frame Base Machine</b>	<b>4 Row 30" 204-00001</b>	<b>4 Row 36"/38"/40" 204-00001</b>	<b>6 Row 30" 206-00001</b>	<b>6 Row 36"/38"/40" 206-00002</b>	<b>8 Row 30" 208-00001</b>	<b>8 Row 36"/38"/40" 208-00002</b>	<b>10 Row 30" 210-00001</b>
Machine Bundle	(1)7210X	(1)7210X	(1)7211X	(1)7212X	(1)7213X	(1)7214X	(1)7255X
Auxiliary Lights *	(1)7030X	(1)7030X	(1)7030X	(1)7267X	(1)7267X	(1)7267X	(1)7267X
Manual	(1)M0150	(1)M0150	(1)M0150	(1)M0150	(1)M0150	(1)M0150	(1)M0150
Reflector Kit *	(1)1K194	(1)1K194	(1)1K194	(1)1K194	(1)1K194	(1)1K194	(1)1K194

<b>Hydraulic Fold Base Machine</b>	<b>8 Row 30" 208-00003</b>	<b>8 Row 36"/38" 208-00004</b>	<b>8 Row 40" 208-00005</b>	<b>12 Row 30" 212-00001</b>	<b>12 Row 36" 212-00002</b>	<b>12 Row 38" 212-00003</b>	<b>16 Row 30" 216-00001</b>
Machine Bundle	(1)7256X	(1)7257X	(1)7258X	(1)7259X	(1)7260X	(1)7261X	(1)7262X
Auxiliary Lights *	(1)7263X	(1)7263X	(1)7263X	(1)7263X	(1)7263X	(1)7263X	(1)7263X
Manual	(1)M0150	(1)M0150	(1)M0150	(1)M0150	(1)M0150	(1)M0150	(1)M0150
Hardware Kit *	-----	-----	-----	-----	(1)7271X	(1)7271X	(1)7271X

\* Contents listing included in each package.

<b>Regular Share Packages</b>	<b>17"(432mm)</b>	<b>19"(483mm)</b>	<b>21"(533mm)</b>	<b>25"(635mm)</b>	<b>27"(686mm)</b>
Share Package (2 Rows)	7201X	7202X	7203X	7204X	7205X
Share Hardware Bag (2 Rows)	7217X	7217X	7217X	7217X	7217X

<b>Hard Surface Share Packages</b>	<b>17"(432mm)</b>	<b>19"(483mm)</b>	<b>21"(533mm)</b>	<b>25"(635mm)</b>	<b>27"(686mm)</b>
Share Package (2 Rows)	7223X	7224X	7225X	7226X	7227X
Share Hardware Bag (2 Rows)	7217X	7217X	7217X	7217X	7217X

<b>Cut-Away Weeding Discs</b>	<b>4 Row 204-01000</b>	<b>6 Row 206-01000</b>	<b>8 Row 208-01000</b>	<b>12 Row 212-01000</b>
Disc Package	(4)7208X	(6)7208X	(8)7208X	(12)7208X
Clamp Package (End Rows)	(1)7209X	(1)7209X	(1)7209X	(1)7209X

**NOTE: Cut-away weeding discs are not recommended for row spacings less than 36".**

<b>Ridging Attachment</b>	<b>4 Row Narrow 204-01001</b>	<b>4 Row Wide 204-01002</b>	<b>6 Row Narrow 206-01002</b>	<b>6 Row Wide 206-01003</b>	<b>8 Row Narrow 208-01001</b>
Blade Bundle	(2)7206X	(5)7207X	(3)7206X	(7)7207X	(4)7206X
Mount Assembly	(5)A6191	(5)A6191	(7)A6191	(7)A6191	(9)A6191

<b>Ridging Attachment</b>	<b>8 Row Wide 208-01002</b>	<b>10 Row Narrow 210-01000</b>	<b>12 Row Narrow 212-01001</b>	<b>12 Row Wide 212-01002</b>	<b>16 Row Narrow 216-01000</b>
Blade Bundle	(9)7207X	(5)7206X	(6)7206X	(13)7207X	(8)7206X
Mount Assembly	(9)A6191	(11)A6191	(13)A6191	(13)A6191	(17)A6191

<b>Liquid Fertilizer Application Package</b>	<b>4-6 Row 258-00009</b>	<b>8 Row 258-00016</b>	<b>10-12 Row 258-00017</b>	<b>16 Row 258-00018</b>
Piston Pump	(1)A6154	(1)A6154	(1)A6154	(1)A6154
Flow Divider	(1)A6158	(1)A6158	(1)A6158	(1)A6570
Pump Mount Assembly	(1)A6312	(1)A6312	(1)A6312	(1)A6312
Drive Wheel Assembly	(1)A6313	(1)A6313	(1)A6313	(1)A6313
Pump Hardware Box	(1)7272X	(1)7273X	(1)7274X	(1)7275X

### Miscellaneous Attachments (One Per Machine)

Dual Lift Assist Wheel Package .....	<b>258-00015</b> (2-A6451 Lift Wheel Assembly/1-7264X Hydraulic Kit)
Rear Telescoping Hitch (Toolbar Mounted) .....	<b>258-00010</b> (1-A6185)
Rear Telescoping Hitch (Dual Lift Assist Wheel Mounted) .....	<b>258-00027</b> (1-A6779)
6" Hitch Extension Package (For Toolbar Mounted Rear Telescoping Hitch) .....	<b>258-00014</b> (2-A6573)
Drive Wheel and Piston Pump Mounting Package .....	<b>258-00024</b> (1-A6312 Pump Mount Assembly/1-A6313 Drive Wheel)

### Miscellaneous Attachments (One Row)

Rotary Hoe Crop Shield with Mounting Support .....	<b>258-00025</b> (1-A6757 Wheel Assembly/1-A6758 Mount Assembly)
Rolling Disc Crop Shield with Mounting Support .....	<b>258-00026</b> (1-A6773 Wheel Assembly/1-A6758 Mount Assembly)
Coil Anhydrous Shank with Knife Mount .....	<b>258-00013</b> (1-7268X)
Cut-Away Weeding Discs .....	<b>258-00007</b> (1-7208X)
KINZE 1500 Cultivator Row Unit .....	<b>258-00011</b> (1-A6560 Unit Assembly/1-A6159 Shank/1-7215X Hardware Package)

# ASSEMBLY - Contents Listing

---

## 17" (432mm) Regular Share Package - 7201X (2 Rows)

(4)D8612 Share

## 19" (483mm) Regular Share Package - 7202X (2 Rows)

(4)D8613 Share

## 21" (533mm) Regular Share Package - 7203X (2 Rows)

(4)D8614 Share

## 25" (635mm) Regular Share Package - 7204X (2 Rows)

(4)D8615 Share

## 27" (686mm) Regular Share Package - 7205X (2 Rows)

(4)D8616 Share

## 17" (432mm) Hard Surface Share Package - 7223X (2 Rows)

(4)D8931 Share

## 19" (483mm) Hard Surface Share Package - 7224X (2 Rows)

(4)D8932 Share

## 21" (533mm) Hard Surface Share Package - 7225X (2 Rows)

(4)D8933 Share

## 25" (635mm) Hard Surface Share Package - 7226X (2 Rows)

(4)D8934 Share

## 27" (686mm) Hard Surface Share Package - 7227X (2 Rows)

(4)D8935 Share

## Share Package Hardware Bag - 7217X (2 Rows)

(8)10593 Plow Bolt,  $\frac{3}{8}$ "-16 x 1"

(8)10622 Flange Nut,  $\frac{3}{8}$ "-16

## Cut-Away Weeding Disc Package - 7208X

(2)A5864 Mount

(1)A6166 Disc Assembly, R.H.

(1)A6194 Clamp W/Hardware

(1)A6183 Disc Assembly, L.H.

## Cut-Away Weeding Disc Clamp Package (End Rows) - 7209X

(1)A6194 Clamp W/Hardware

(2)D0750-08 Tube, 2" Square x 6"

## Ridging Attachment Blade Bundle (Narrow Rows) - 7206X

(4)D8738 Blade (13  $\frac{3}{4}$ "[349mm] Total Length)

(2)10599 Carriage Bolt,  $\frac{3}{8}$ "-16 x 1  $\frac{1}{4}$ "

(2)10101 Hex Nut,  $\frac{3}{8}$ "-16

(2)10210 Washer,  $\frac{3}{8}$ " USS

## Ridging Attachment Blade Bundle (Wide Rows) - 7207X

(1)A7968 Blade, R.H. (17  $\frac{3}{4}$ " [451mm] Total Length)

(1)A7969 Blade, L.H. (17  $\frac{3}{4}$ " [451mm] Total Length)

(1)D10973 Spreader

(2)10001 Cap Screw,  $\frac{3}{8}$ "-16 x 1"

(2)10229 Lock Washer,  $\frac{3}{8}$ "

(2)10101 Hex Nut,  $\frac{3}{8}$ "-16

(2)10210 Washer,  $\frac{3}{8}$ " USS

# ASSEMBLY - Contents Listing

---

## Liquid Fertilizer Pump Hardware Box - 7272X

### 4-6 Row

(1)D0829	Spring
(1)4300-14	Clear Hose, 7/16" x 150' (4572cm)
(1)4200-01	Hose, 1 1/4" x 22' (671cm)
(1)A6567	Hardware And Fitting Bag
(1)D1514	Adapter
(1)D1515	Dust Cap, 1 1/4"
(1)D1516	Adapter
(1)D1517	Dust Plug
(1)10672	Hose Clamp, No. 28
(4)10674	Hose Clamp, No. 24
(3)10626	Adapter, 1 1/4" NPT to 1 1/4" Barb
(1)10629	Elbow, 1 1/4"
(1)10389	Pipe Nipple, 3/4"
(13)D8816	Hose Barb
(17)10673	Hose Clamp, No. 8
(1)10679	Hose Barb Tee, 1/2"
(2)10292	Plug, 1/4" NPT
(1)10615	Reducing Bushing, 1 1/2" to 1 1/4"
(8)10210	Washer, 3/8" USS
(1)A4976	Ball Valve
(1)3200-79	Chain, No. 2050
(30)D1512	Tie Strap, 6" (152 mm)
(5)D2984	Tie Strap, 30" (762 mm)
(1)R1146	Sprocket, 18 Tooth
(1)A3893	Strainer

## Liquid Fertilizer Pump Hardware Box - 7273X

### 8 Row

(1)D0829	Spring
(1)4300-14	Clear Hose, 7/16" x 150' (4572cm)
(1)4200-01	Hose, 1 1/4" x 22' (671cm)
(1)A6568	Hardware And Fitting Bag
(1)D1514	Adapter
(1)D1515	Dust Cap, 1 1/4"
(1)D1516	Adapter
(1)D1517	Dust Plug
(1)10672	Hose Clamp, No. 28
(4)10674	Hose Clamp, No. 24
(3)10626	Adapter, 1 1/4" NPT to 1 1/4" Barb
(1)10629	Elbow, 1 1/4"
(1)10389	Pipe Nipple, 3/4"
(18)D8816	Hose Barb
(21)10673	Hose Clamp, No. 8
(1)10679	Hose Barb Tee, 1/2"
(4)10292	Plug, 1/4" NPT
(1)10615	Reducing Bushing, 1 1/2" to 1 1/4"
(8)10210	Washer, 3/8" USS
(2)10104	Hex Nut, 5/8"-11
(2)10230	Lock Washer, 5/8"
(1)10733	Elbow, 3/4" NPT
(2)10734	Hose Barb, 3/4"
(1)10735	Street Elbow
(2)10675	Hose Clamp, No. 20
(1)A4976	Ball Valve
(1)3200-79	Chain, No. 2050
(30)D1512	Tie Strap, 6" (152 mm)
(10)D2984	Tie Strap, 30" (762 mm)
(1)R1146	Sprocket, 18 Tooth
(1)A6527	Support
(1)D1114	U-Bolt, 7" x 7" x 5/8"-11
(1)4205-10	Hose, 3/4" x 200" (5080mm)
(1)A3893	Strainer

# ASSEMBLY - Contents Listing

---

## Liquid Fertilizer Pump Hardware Box - 7274X

### 10-12 Row

(1)D0829	Spring
(1)4300-15	Clear Hose, 7/16" x 300' (9144cm)
(1)4200-03	Hose, 1 1/4" x 32' (975cm)
(1)A6569	Hardware And Fitting Bag
(1)D1514	Adapter
(1)D1515	Dust Cap, 1 1/4"
(1)D1516	Adapter
(1)D1517	Dust Plug
(1)10672	Hose Clamp, No. 28
(4)10674	Hose Clamp, No. 24
(3)10626	Adapter, 1 1/4" NPT to 1 1/4" Barb
(1)10629	Elbow, 1 1/4"
(1)10389	Pipe Nipple, 3/4"
(26)D8816	Hose Barb
(29)10673	Hose Clamp, No. 8
(1)10679	Hose Barb Tee, 1/2"
(2)10292	Plug, 1/4" NPT
(1)10615	Reducing Bushing, 1 1/2" to 1 1/4"
(8)10210	Washer, 3/8" USS
(2)10104	Hex Nut, 5/8"-11
(2)10230	Lock Washer, 5/8"
(1)10733	Elbow, 3/4" NPT
(2)10734	Hose Barb, 3/4"
(1)10735	Street Elbow
(2)10675	Hose Clamp, No. 20
(1)A4976	Ball Valve
(1)3200-79	Chain, No. 2050
(30)D1512	Tie Strap, 6" (152 mm)
(10)D2984	Tie Strap, 30" (762 mm)
(1)R1146	Sprocket, 18 Tooth
(1)A6527	Support
(1)D1114	U-Bolt, 7" x 7" x 5/8"-11
(1)4205-10	Hose, 3/4" x 200" (5080 mm)
(1)A3893	Strainer

## Liquid Fertilizer Pump Hardware Box - 7275X

### 16 Row

(1)D0829	Spring
(1)4300-15	Clear Hose, 7/16" x 300' (9144cm)
(1)4200-03	Hose, 1 1/4" x 32' (975cm)
(1)A6571	Hardware And Fitting Bag
(1)D1514	Adapter
(1)D1515	Dust Cap, 1 1/4"
(1)D1516	Adapter
(1)D1517	Dust Plug
(1)10672	Hose Clamp, No. 28
(4)10674	Hose Clamp, No. 24
(3)10626	Adapter, 1 1/4" NPT to 1 1/4" Barb
(1)10629	Elbow, 1 1/4"
(1)10389	Pipe Nipple, 3/4"
(34)D8816	Hose Barb
(37)10673	Hose Clamp, No. 8
(1)10679	Hose Barb Tee, 1/2"
(1)10615	Reducing Bushing, 1 1/2" to 1 1/4"
(8)10210	Washer, 3/8" USS
(2)10104	Hex Nut, 5/8"-11
(2)10230	Lock Washer, 5/8"
(1)10733	Elbow, 3/4" NPT
(2)10734	Hose Barb, 3/4"
(1)10735	Street Elbow
(2)10675	Hose Clamp, No. 20
(1)10737	Reducing Bushing, 3/4" x 1 1/4"
(1)A4976	Ball Valve
(1)3200-79	Chain, No. 2050
(30)D1512	Tie Strap, 6" (152 mm)
(10)D2984	Tie Strap, 30" (762 mm)
(1)R1146	Sprocket, 18 Tooth
(1)A6527	Support
(1)D1114	U-Bolt, 7" x 7" x 5/8"-11
(1)4205-10	Hose, 3/4" x 200" (5080 mm)
(1)A3893	Strainer

# ASSEMBLY - Contents Listing

---

## **Dual Lift Assist Wheel Package Hydraulic Kit**

### **-7264X**

(2)A5482 Cylinder, 3 1/2" x 8"  
(4)A1024 Hose Assembly, 3/8" x 116"  
(2)A1047 Hose Assembly, 3/8" x 60"  
(2)D4086 Pioneer (ISO) Tip  
(2)2703-08 Bulkhead Tee  
(2)306-08 Lock Nut, 3/4"-16  
(4)2501-08-08 Elbow  
(10)D2984 Tie Strap, 32"  
(1)A0270 Flow Control Valve  
(1)2404-08-06 Adapter  
(1)6505-06-08 Adapter  
(2)A7861 Breather Plug, 1/2" NPT

## **Coil Anhydrous Shank Package - 7268X**

(1)D9274 Coil Shank  
(2)D9125 Mount  
(2)D9126 Spacer  
(2)D2071 Plate  
(1)A6572 Hardware Bag  
    (1)10013 Cap Screw, 5/8"-11 x 3 1/2"  
    (1)10061 Cap Screw, 3/8"-16 x 3 1/2"  
    (1)10107 Lock Nut, 5/8"-11  
    (1)10108 Lock Nut, 3/8"-16  
    (4)10585 Cap Screw, 1/2"-13 x 3 1/4"  
    (11)10111 Lock Nut, 1/2"-13  
    (4)10397 Cap Screw, 1/2"-13 x 2 3/4"  
    (3)10016 Cap Screw, 1/2"-13 x 2"

## **Cut-Away Weeding Discs Package - 7208X**

(2)A5864 Mount W/Set Screw  
(1) ----- Disc Assembly  
(1) ----- Clamp Assembly  
(1) ----- Disc Assembly

## **Shank Hardware Package - 7215X**

(2)D8175 U-Bolt, 7" x 7" (Diamond) x 5/8"-11  
(4)D7805 Special Washer  
(4)10104 Hex Nut, 5/8"-11  
(4)10230 Lock Washer, 5/8"  
(1)A6035 Shank Point  
(1)10039 Cap Screw, 1/2"-13 x 1 3/4"  
(1)10111 Lock Nut, 1/2"-13  
(1)10009 Cap Screw, 5/8"-11 x 2 1/2"  
(1)10107 Lock Nut, 5/8"-11  
(1)10049 Cap Screw, 3/8"-16 x 2 1/2"  
(1)10108 Lock Nut, 3/8"-16

# ASSEMBLY - Contents Listing

---

# PARTS LIST INDEX

---

Coil Anhydrous Shank With Knife Mount .....	P17
Coulter Assembly .....	P16
Cut-Away Weeding Discs .....	P18
Cylinders .....	P8
Decals, Reflectors And Tie Straps .....	P38
Dual Lift Assist Wheels .....	P10
Electrical Components .....	P7
Hydraulic Fold Toolbar Assembly .....	P4
Liquid Fertilizer Drive Wheel Assembly .....	P22
Liquid Fertilizer Piston Pump (Crankcase Assembly) .....	P26
Liquid Fertilizer Piston Pump (Cylinder Assembly) .....	P28
Liquid Fertilizer Piston Pump Flow Divider, 4-12 Row Machines .....	P30
Liquid Fertilizer Piston Pump Flow Divider, 16 Row Machine .....	P32
Liquid Fertilizer Pump Mount Assembly .....	P24
Rear Telescoping Hitch (Dual Lift Wheel Assist Mounted) .....	P36
Rear Telescoping Hitch (Toolbar Mounted) .....	P34
Ridging Attachment .....	P19
Rigid Toolbar Assembly .....	P2
Rotary Hoe/Rolling Disc Crop Shield With Mounting Support .....	P20
Row Unit Assembly .....	P12
Shank Assembly .....	P14
Numerical Index .....	a

# RIGID TOOLBAR ASSEMBLY

CCU001(CLT39)

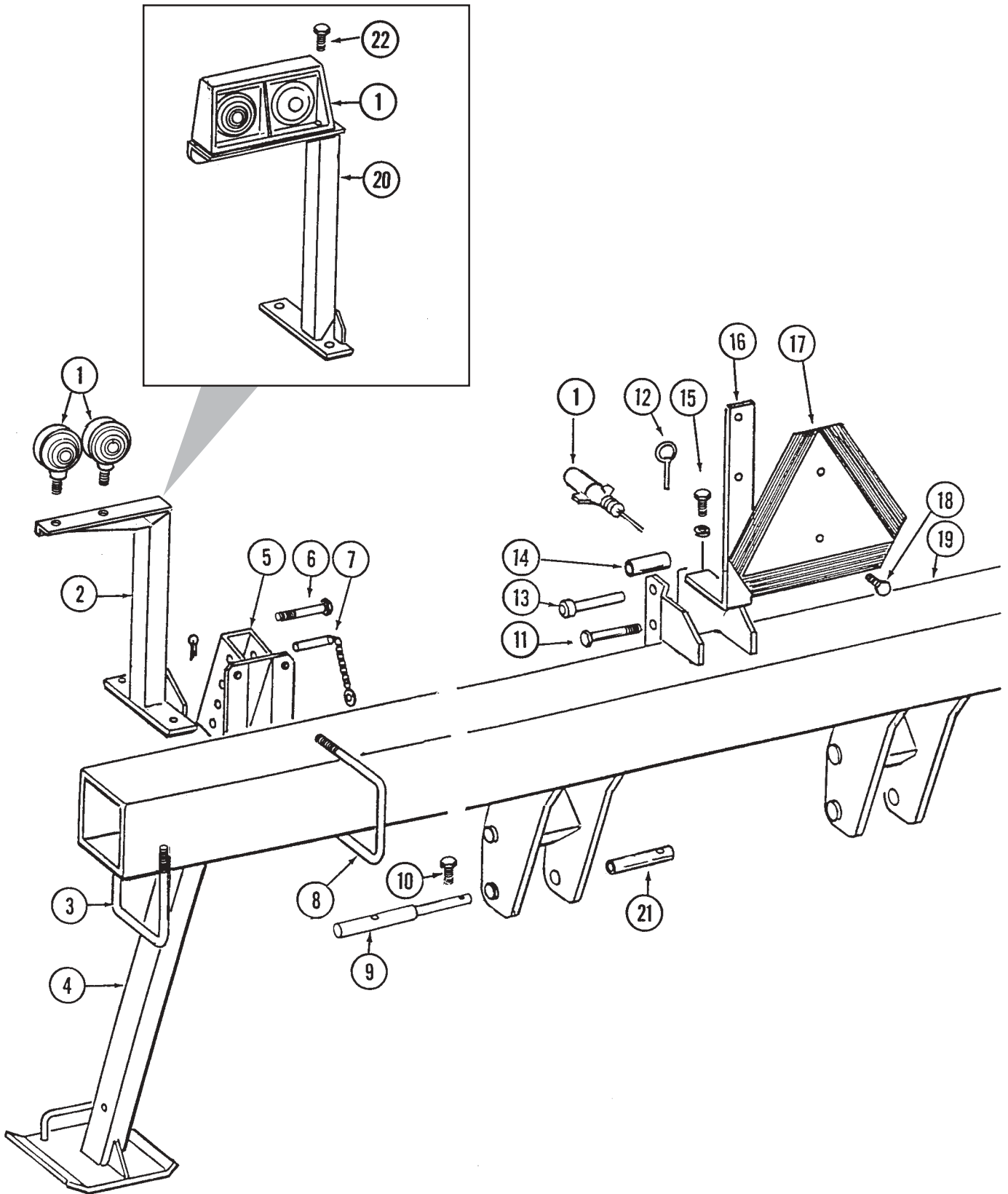

# RIGID TOOLBAR ASSEMBLY

---

ITEM	PART NO.	QTY.	DESCRIPTION
1.		-	See "Electrical Components", Page P7
2.	GA4775	1	Bracket, L.H. (Shown)
	GA4776	1	Bracket, R.H.
3.	GD7145	2	U-Bolt, 7" x 7" x 1/2"-13
	G10228	4	Lock Washer, 1/2"
	G10102	4	Hex Nut, 1/2"-13
4.	GA6076	2	Jack Stand
5.	GA4707	2	Mount
6.	G10016	2	Hex Head Cap Screw, 1/2"-13 x 2"
	G10111	2	Lock Nut, 1/2"-13
7.	GA4733	2	Detent Pin W/Chain
8.	GD1114	4	U-Bolt, 7" x 7" x 5/8"-11
	G10230	8	Lock Washer, 5/8"
	G10104	8	Hex Nut, 5/8"-11
9.	GD9750	2	Pin, 11 3/4"
10.	G10048	4	Hex Head Cap Screw, 3/8"-16 x 2"
	G10108	4	Lock Nut, 3/8"-16
11.	G10678	1	Hex Head Cap Screw, 1"-8 x 5 1/2"
	G10396	1	Lock Nut, 1"-8
12.	GD2557	3	Lynch Pin, 7/16"
13.	GA6078	1	Pin, 4 1/2"
14.	GD8701	1	Bushing, 2"
15.	G10001	2	Hex Head Cap Screw, 3/8"-16 x 1"
	G10229	2	Lock Washer, 3/8"
16.	GD7152	1	SMV Mounting Bracket
17.	GD2199	1	SMV Sign
18.	G10023	2	Hex Head Cap Screw, 1/4"-20 x 3/4"
	G10110	2	Lock Nut, 1/4"-20
19.	A6196	1	Toolbar, 7" x 7" x 170" (4318mm), 4 Row 30"/36"/38"/40" <b>(Non-Stock Item)</b>
	A6197	1	Toolbar, 7" x 7" x 190" (4826mm), 6 Row 30" <b>(Non-Stock Item)</b>
	A6198	1	Toolbar, 7" x 7" x 250" (6350mm), 6 Row 36"/38"/40" And 8 Row 30" <b>(Non-Stock Item)</b>
	A6199	1	Toolbar, 7" x 7" x 330" (8382mm), 8 Row 36"/38"/40" And 10 Row 30" <b>(Non-Stock Item)</b>
20.	GA6823	-	Bracket, L.H. Side (Shown)
	GA6824	-	Bracket, R.H. Side
21.	GD9749	2	Bushing, 3 3/4"
22.	G10064	8	Hex Head Cap Screw, 1/4"-20 x 1"
	G10209	8	Washer, 1/4" USS
	G10110	8	Lock Nut, 1/4"-20

# HYDRAULIC FOLD TOOLBAR ASSEMBLY

CCU010(CLT40a)

8 Row Shown

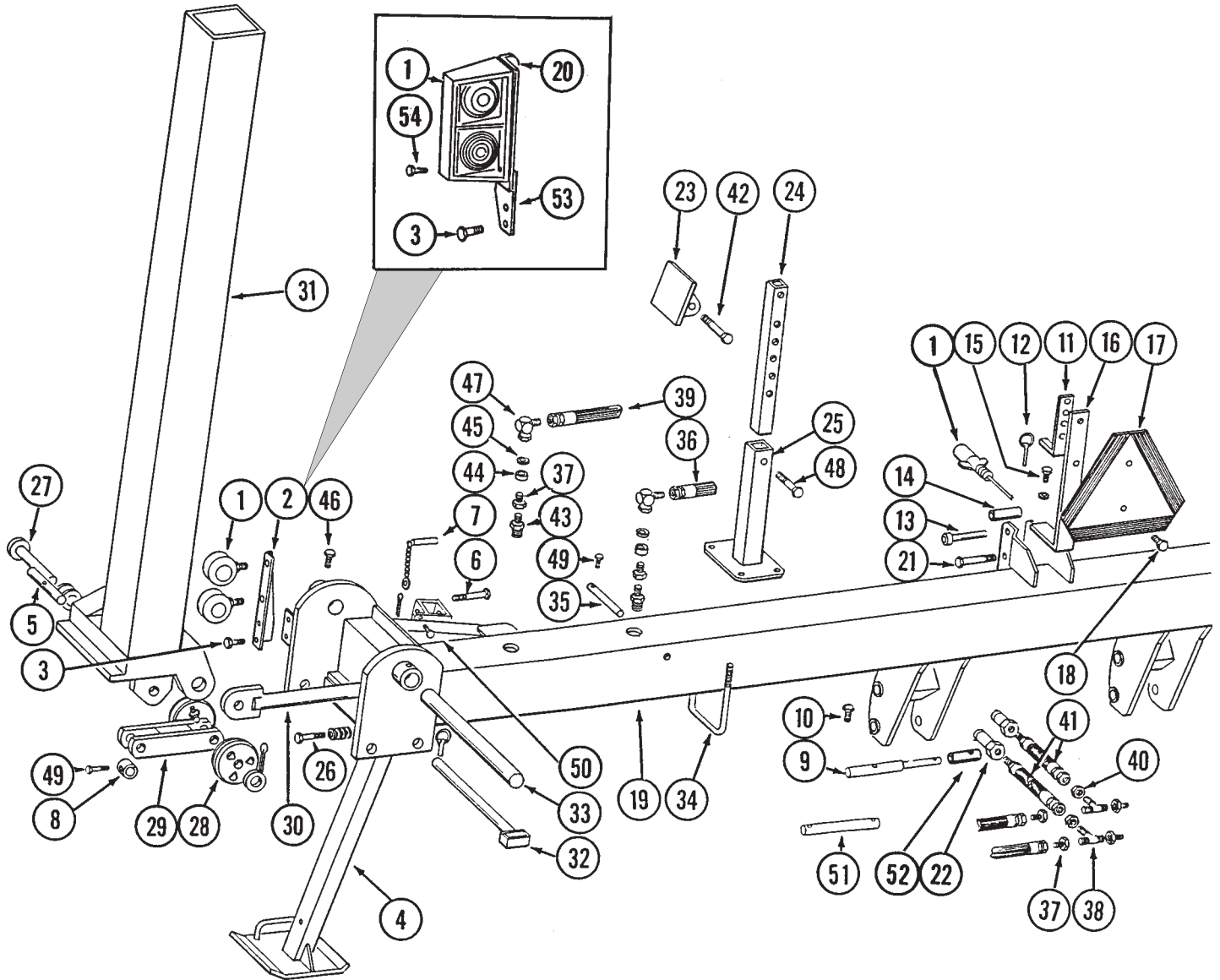

ITEM	PART NO.	QTY.	DESCRIPTION
1.		-	See "Electrical Components", Page P7
2.	GD7141	1	Bracket, L.H. (Shown)
	GD7154	1	Bracket, R.H.
3.	G10001	4	Hex Head Cap Screw, $\frac{3}{8}$ "-16 x 1"
	G10108	4	Lock Nut, $\frac{3}{8}$ "-16
4.	GA6098	2	Jack Stand
5.	GD9247	2	Pin, 1 $\frac{1}{4}$ " x 5"
6.	G10016	2	Hex Head Cap Screw, $\frac{1}{2}$ "-13 x 2"
	G10111	2	Lock Nut, $\frac{1}{2}$ "-13
7.	GA4733	2	Detent Pin W/Chain
8.	GD9348	2	Sleeve
9.	GD9750	2	Pin, 11 $\frac{3}{4}$ " Category 2/3, 8 And 12 Row Machines Prior To Serial No. 800684
10.	G10048	4	Hex Head Cap Screw, $\frac{3}{8}$ "-16 x 2"
	G10108	4	Lock Nut, $\frac{3}{8}$ "-16

# HYDRAULIC FOLD TOOLBAR ASSEMBLY

ITEM	PART NO.	QTY.	DESCRIPTION
11.	GA6551	1	Mount
12.	GD2557	3	Lynch Pin, 7/16"
13.	GA6078	1	Pin, 4 1/2"
14.	GD8701	1	Bushing, 2"
15.	G10001	2	Hex Head Cap Screw, 3/16"-16 x 1"
	G10229	2	Lock Washer, 3/8"
16.	GD7152	1	SMV Mounting Bracket
17.	GD2199	1	SMV Sign
18.	G10023	2	Hex Head Cap Screw, 1/4"-20 x 3/4"
	G10110	2	Lock Nut, 1/4"-20
19.	A6380	1	Center Toolbar, 7" x 7" x 137" (3480mm), 8 Row 30" <b>(Non-Stock Item)</b>
	A6064	1	Center Toolbar, 7" x 7" x 168" (4267mm), 8 Row 36"/38" <b>(Non-Stock Item)</b>
	A6553	1	Center Toolbar, 7" x 7" x 183" (4648mm), 8 Row 40" <b>(Non-Stock Item)</b>
	A6062	1	Center Toolbar, 7" x 7" x 197" (5004mm), 12 Row 30" <b>(Non-Stock Item)</b>
	A6389	1	Center Toolbar W/Forward Toolbar, 7" x 7" x 239" (6071mm), 12 Row 36" <b>(Non-Stock Item)</b>
	A6390	1	Center Toolbar W/Forward Toolbar, 7" x 7" x 244" (6198mm), 12 Row 38" <b>(Non-Stock Item)</b>
	A6561	1	Center Toolbar W/Forward Toolbar, 7" x 7" x 257" (6528mm), 16 Row 30" <b>(Non-Stock Item)</b>
20.	GD9707	1	Bracket L.H. Side (Shown)
	GD9708	-	Bracket, R.H. Side
21.	G10064	8	Hex Head Cap Screw, 1/4"-20 x 1"
	G10209	8	Washer, 1/4" USS
	G10110	8	Lock Nut, 1/4"-20
22.	GD4086	2	ISO Coupler
23.	GA6423	2	Stop Bracket
24.	GD9119	2	Stop Tube
25.	GA6424	2	Stop Post
26.	G10028	4	Hex Head Cap Screw, 3/4"-10 x 3"
	GD9259	12	Spacer
	G10194	16	Washer, 3/4" SAE
	G10112	4	Lock Nut, 3/4"-10
27.	GA6063	2	Wing Fold Pin
	G10322	6	Machine Bushing
	G10460	2	Cotter Pin, 1/4" x 2"
28.	GD9041	4	Wheel
29.	GA6072	2	Link
30.	-	-	See "Wing Fold Cylinder", Page P8
31.	A6384	1	Right Wing W/Grease Fitting, 7" x 7" x 56 1/4" (1429mm), 8 Row 30" <b>(Non-Stock Item)</b>
	A6383	1	Left Wing W/Grease Fitting, 7" x 7" x 56 1/4" (1429mm), 8 Row 30" <b>(Non-Stock Item)</b>
	A6386	1	Right Wing W/Grease Fitting, 7" x 7" x 73 1/4" (1861mm), 8 Row 36"/38"/40" <b>(Non-Stock Item)</b>
	A6385	1	Left Wing W/Grease Fitting, 7" x 7" x 73 1/4" (1861mm), 8 Row 36"/38"/40" <b>(Non-Stock Item)</b>
	A6388	1	Right Wing W/Grease Fitting, 7" x 7" x 86 1/4" (2191mm), 12 Row 30" <b>(Non-Stock Item)</b>
	A6387	1	Left Wing W/Grease Fitting, 7" x 7" x 86 1/4" (2191mm), 12 Row 30" <b>(Non-Stock Item)</b>
	A6392	1	Right Wing W/Grease Fitting, 7" x 7" x 102 1/4" (2597mm), 12 Row 36" <b>(Non-Stock Item)</b>
	A6391	1	Left Wing W/Grease Fitting, 7" x 7" x 102 1/4" (2597mm), 12 Row 36" <b>(Non-Stock Item)</b>

(Continued)

# HYDRAULIC FOLD TOOLBAR ASSEMBLY

ITEM	PART NO.	QTY.	DESCRIPTION
31.(Cont.)	A6394	1	Right Wing W/Grease Fitting, 7" x 7" x 111 1/4" (2826mm), 12 Row 38" <b>(Non-Stock Item)</b>
	A6393	1	Left Wing W/Grease Fitting, 7" x 7" x 111 1/4" (2826mm), 12 Row 38" <b>(Non-Stock Item)</b>
	A6562	1	Right Wing W/Grease Fitting, 7" x 7" x 116 1/4" (2953mm), 16 Row 30" <b>(Non-Stock Item)</b>
	A6563	1	Left Wing W/Grease Fitting, 7" x 7" x 116 1/4" (2953mm), 16 Row 30" <b>(Non-Stock Item)</b>
	G10641	-	Grease Fitting, 1/8" NPT
32.	GA6528	2	Stop Pin
	GD2557	2	Lynch Pin, 7/16"
33.	GD8678	2	Hinge Pin, 2 1/2" x 18 5/8"
34.	GD1114	4	U-Bolt, 7" x 7" x 5/8"-11
	G10230	8	Lock Washer, 5/8"
	G10104	8	Hex Nut, 5/8"-11
35.	GD7302	2	Pin, 1" x 6", 8 Row 30"/36"/38"/40" And 12 Row 30"
	GD9268	2	Pin, 1 1/4" x 6", 12 Row 36"/38" And 16 Row 30"
36.	* A1181	2	Hose Assembly, 1/4" x 36" (914 mm), 8 Row 30"
	* A1155	2	Hose Assembly, 1/4" x 48" (1219 mm), 8 Row 36"/38"
	* A1139	2	Hose Assembly, 1/4" x 40" (1016 mm), 8 Row 40"
	* A1141	2	Hose Assembly, 1/4" x 62" (1575 mm), 12 Row 30"
	* A1114	2	Hose Assembly, 1/4" x 85" (2159 mm), 12 Row 36"
	* A1170	2	Hose Assembly, 1/4" x 90" (2286 mm), 12 Row 38"
	* A1102	2	Hose Assembly, 1/4" x 95" (2413 mm), 16 Row 30"
37.	G2406-08-06	8	Reducer
38.	G2703-08	2	Bulkhead Tee
39.	* A1155	2	Hose Assembly, 1/4" x 48" (1219 mm), 8 Row 30"
	* A1154	2	Hose Assembly, 1/4" x 72" (1829 mm), 8 Row 36"/38"/40"
	* A1113	2	Hose Assembly, 1/4" x 80" (2032 mm), 12 Row 30"
	* A1114	2	Hose Assembly, 1/4" x 85" (2159 mm), 12 Row 36"
	* A1170	2	Hose Assembly, 1/4" x 90" (2286 mm), 12 Row 38"
	* A1102	2	Hose Assembly, 1/4" x 95" (2413 mm), 16 Row 30"
40.	G306-08	2	Lock Nut, 3/4"-16
41.	* A1047	2	Hose Assembly, 3/8" x 60"
42.	G10036	2	Hex Head Cap Screw, 5/8"-13 x 4"
	G10107	2	Lock Nut, 5/8"-13
43.	G6400-08	4	Adapter
44.	GD9518	4	Seal Insert, 1 1/2" Thick, 8 Row 30"/36"/38"/40" And 12 Row 30"
	GD9294	4	Seal Insert, 3/4" Thick, 12 Row 36"/38" And 16 Row 30"
45.	GD9325	4	Fender Washer
46.	G10061	4	Hex Head Cap Screw, 3/8"-16 x 3 1/2"
	G10108	4	Lock Nut, 3/8"-16
47.	G6500-06	4	Elbow, 9/16"-18 Swivel
48.	G10038	2	Hex Head Cap Screw, 1/2"-13 x 3"
	G10111	2	Lock Nut, 1/2"-13
49.	G10049	2	Hex Head Cap Screw, 3/8"-16 x 2 1/2"
	G10108	2	Lock Nut, 3/8"-16
50.	G10007	1	Hex Head Cap Screw, 5/8"-11 x 1 1/2"
	G10107	1	Lock Nut, 5/8"-11
51.	GD9333	2	Pin, Category 3 Only, All 16 Row, 8 And 12 Row Serial No. 800684 & On
52.	GD9749	2	Bushing, 3 3/4"
53.	GD9710	2	Extension

\* Hydraulic hose is not stocked by Kinze® Repair Parts, but can be made available on a special order basis. Call for quote.

# ELECTRICAL COMPONENTS

CCU001(TWL/23/ELC9/CLT37/CLT38)

## STYLE A

Uses Item 4  
Wiring Harness

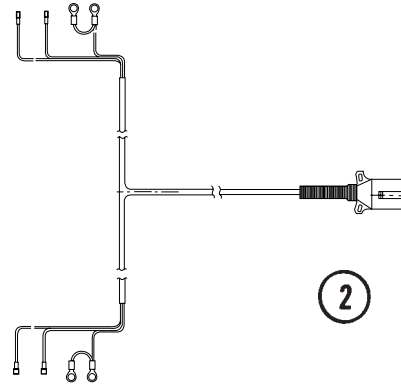
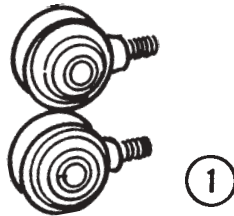

## STYLE B

Uses Item 2  
Wiring Harness

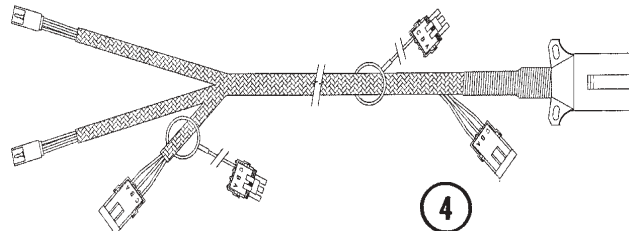
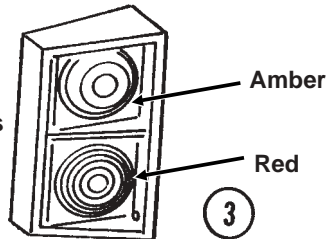

ITEM	PART NO.	QTY.	DESCRIPTION
1.	GA4122	2	Single Red Light Assembly Complete W/Female Terminal
	GA4123	2	Double Amber Light Assembly Complete W/Male Terminal
	GR0968	-	Bulb, No. 1156
	GR0970	-	Red Lens
	GR0969	-	Amber Lens
	G10289	-	Hex Nut, 1/2"-20
	G10525	-	Star Washer, 1/2"
	G10266	-	Female Terminal
	G10269	-	Male Terminal
	2.	GA4783	1
GA4784		-	Light Wiring Harness W/7 Terminal Female Connector, 258", 6 Row 36"/38"/40", 8 Row 30"/36"/38"/40" And 10 Row 30" Rigid Machines ( <b>Sub G7267X</b> )
GA6413		-	Light Wiring Harness W/7 Terminal Female Connector, 227", All Hydraulic Fold Machines ( <b>Sub G7263X</b> )
GA5385		-	7 Terminal Female Connector
3.	GA6699	1	Double Light Assembly (Shown)
	GA6700	1	Double Light Assembly
	GR1203	-	Red Lens
	GR1204	-	Amber Lens
	GR1205	-	Cover
	GR1206	-	Rubber Grommet (4)
	GR1207	-	Lamp Unit
	GR1208	-	Bulb
4.	GA6816	1	Light Wiring Harness W/7 Terminal Female Connector, 185", 4 Row 30"/36"/38"/40" And 6 Row 30" Rigid Machines
	GA6817	-	Light Wiring Harness W/7 Terminal Female Connector, 263", 6 Row 36"/38"/40", 8 Row 30"/36"/38"/40" And 10 Row 30" Rigid Machines
	GA6831	-	Light Wiring Harness W/7 Terminal Female Connector, 232", All Hydraulic Fold Machines
	GA5385	-	7 Terminal Female Connector

# WING FOLD CYLINDER, All 8 Row And 12 Row 30"

CYL032/CYL047/CYL053(CYL29)

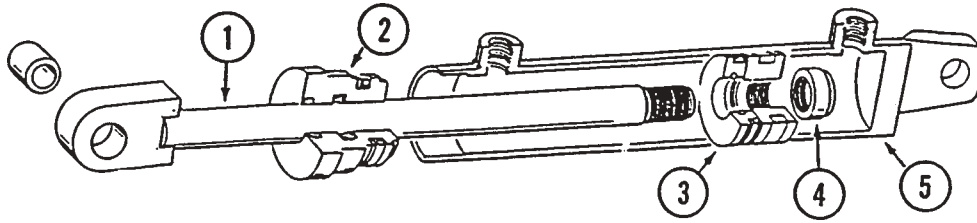

ITEM	PART NO.	QTY.	DESCRIPTION
1.	GA6605	1	Rod Assembly W/Grease Fitting And Bushing
2.	GD6576	1	Gland
3.	GD7884	1	Piston
4.	GR0987	1	Lock Nut, 1 1/4"-12
5.	GA6604	1	Barrel
A.	GA6061	-	Cylinder Complete, 4" x 15"
B.	GR1057	-	Seal Kit, Includes: (1)T Seal, (2)O-Rings, (1)BU Ring, (1)U-Cup, (1)Wiper, (1)Wear Ring

# WING FOLD CYLINDER, 12 Row 36"/38" And 16 Row 30"

CYL053(CYL30)

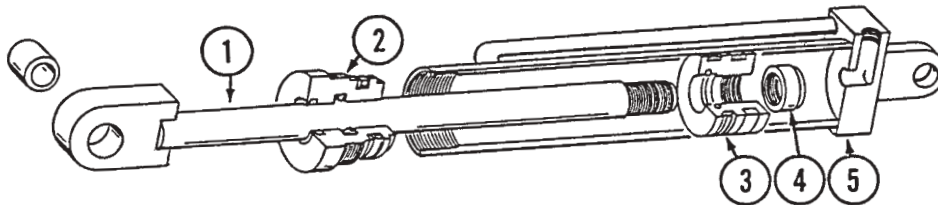

ITEM	PART NO.	QTY.	DESCRIPTION
1.	GA6596	1	Rod Assembly W/Grease Fitting And Bushing
2.	GD9296	1	Gland
3.	GD9297	1	Piston
4.	GR0987	1	Lock Nut, 1 1/4"-12
5.	GA6595	1	Barrel
A.	GA6378	-	Cylinder Complete, 5" x 14"
B.	GR1187	-	Seal Kit, Includes: (1)Uniring, (2)O-Rings, (1)BU Ring, (1)U-Cup, (1)Wiper, (1)Wear Ring

# DUAL LIFT ASSIST CYLINDER

CYL048(CYL22)

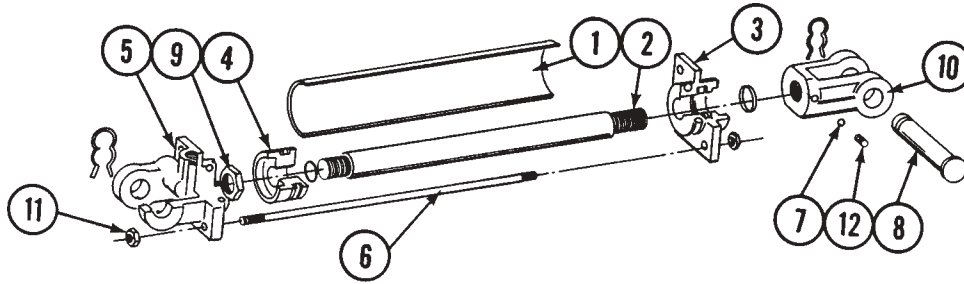

ITEM	PART NO.	QTY.	DESCRIPTION
------	----------	------	-------------

1.	R1023	1	Barrel <b>(Non-Stock Item)</b>
2.	GR0709	1	Shaft
3.	GR1025	1	Gland
4.	GR1026	1	Piston
5.	GR1027	1	Clevis
6.	GR1024	4	Tie Rod
7.	GR0716	1	Nylon Ball
8.	GR0717	2	Pin W/Clip
9.	GR0663	1	Nut
10.	GR0714	1	Clevis
11.	GR0181	8	Hex Nut, 1/2"-13
12.	G10210	1	Set Screw, 3/8"-16 x 3/8"

- A. GA5482A - Cylinder Complete W/Pins And Clips, 3 1/2" x 8"
- B. GR1028 - Seal Kit, Includes: (1)Wiper, (4)BU Rings, (4)O-Rings, (1)U-Cup

**IDENTIFICATION NOTE:** "Energy" cast in clevis.

# DUAL LIFT ASSIST CYLINDER

CYL048(CYL23)

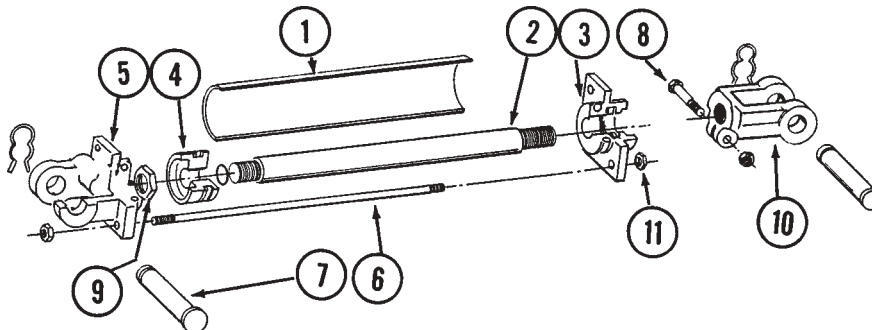

ITEM	PART NO.	QTY.	DESCRIPTION
------	----------	------	-------------

1.	GR1274	1	Barrel
2.	GR1273	1	Shaft
3.	GR1271	1	Gland
4.	GR1272	1	Piston
5.	GR1270	1	Clevis
6.	GR1024	4	Tie Rod
7.	GR0717	2	Pin W/Clip
	GR0193	-	Clip
8.	G10047	1	Hex Head Cap Screw, 3/8"-16 x 1 3/4"
	G10101	1	Hex Nut, 3/8"-16
9.	GR1278	1	Nut
10.	GR1276	1	Clevis
11.	GR0181	8	Nut

- A. GA5482B - Cylinder Complete, 3 1/2" x 8"
- B. GR1279 - Seal Kit, Includes: (3) BU Seals, (5) O-Rings, (1) C/R Seal

**IDENTIFICATION NOTE:** Decal on barrel identifies "Lion Hydraulics".

# DUAL LIFT ASSIST WHEELS

CCU008/HTA014/PLA015(CLT50b/CLT34c)

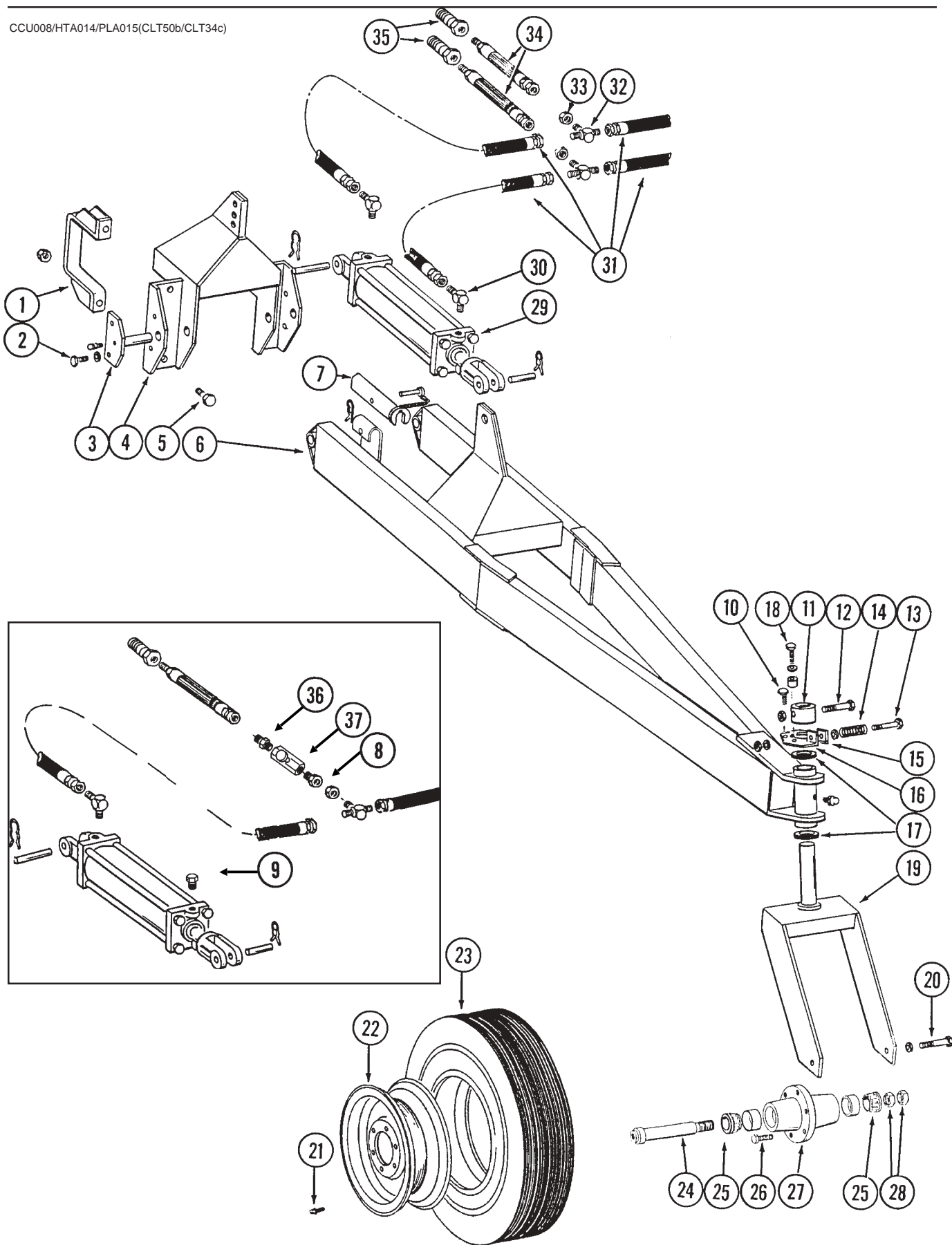

# DUAL LIFT ASSIST WHEELS

ITEM	PART NO.	QTY.	DESCRIPTION
1.	GA5921	1	Clamp
2.	G10037	4	Hex Head Cap Screw, 1/2"-13 x 1 1/4"
	G10111	4	Lock Nut, 1/2"-13
3.	GA6452	2	Hammer Strap W/Grease Fitting
	G10641	-	Grease Fitting, 1/8" NPT
4.	GA6473	1	Mount
5.	G10645	4	Hex Head Cap Screw, 1"-8 x 3"
	G10698	4	Square Nut, 1"-8
6.	GA6447	1	Lift Assist Frame W/Grease Fittings
	G10641	1	Grease Fitting, 1/8" NPT
7.	GA5761	1	Lockup W/Pin
8.	G6505-06-08	1	Adapter, 3/4"-16 JIC Female To 3/8" NPT Male
9.	GA7861	2	Breather Plug, 1/2" NPT
10.	G10008	2	Hex Head Cap Screw, 5/8"-11 x 2"
	GB0218	2	Bushing
	GD7805	4	Special Washer
	G10230	2	Lock Washer, 5/8"
	G10104	2	Hex Nut, 5/8"-11
11.	GD9170	1	Roller
12.	G10032	1	Hex Head Cap Screw, 1/2"-13 x 3 3/4"
	G10228	1	Lock Washer, 1/2"
	G10102	1	Hex Nut, 1/2"-13
13.	G10713	1	Hex Head Cap Screw, 7/16"-14 x 6"
	G10081	2	Washer, 7/16" USS
	G10113	1	Lock Nut, 7/16"-14
14.	GD9208	1	Spring
15.	GA6454	1	Roller Ring, R.H.
16.	GA6455	1	Roller Ring, L.H.
17.	G10234	2	Bushing, 10 Gauge
18.	G10007	2	Hex Head Cap Screw, 5/8"-11 x 1 1/2"
	GB0218	2	Bushing
	GD7805	4	Special Washer
	G10230	2	Lock Washer, 5/8"
	GD9179	2	Sleeve
19.	GA6443	1	Caster Wheel
20.	G10026	2	Hex Head Cap Screw, 3/4"-10 x 2"
	G10231	2	Lock Washer, 3/4"
21.	GD1166	1	Valve Stem
22.	GA5196	1	Wheel W/Valve Protector, 15" x 5"
23.	GD0844	1	Tire, 7.60" x 15", 4 Ply
24.	GA2558	1	Spindle
25.	GA0895	2	Bearing
26.	GR0270	6	Lug Bolt, 9/16"-18
27.	GA2148	1	Hub W/Cups, 6 Bolt
	GR0434	-	Cup
28.	G10087	2	Jam Nut, 1 1/2", Grade 2
29.		-	See "Dual Lift Assist Cylinder", Page P9
30.	G2501-08-08	4	Elbow, 3/4"-16 JIC To 1/2" NPT
31.	* A1024	4	Hose Assembly, 3/8" x 116" (2946 mm)
32.	G2703-08	2	Bulkhead Tee, 3/4"-16 JIC
33.	G306-08	2	Lock Nut, 3/4"-16
34.	* A1047	2	Hose Assembly, 3/8" x 60" (1524 mm)
35.	GD4086	1	ISO Coupler
36.	G2404-08-06	1	Adapter, 3/4"-16 JIC To 3/8" NPT Male
37.	GA0270	1	Flow Control Valve
	GR0767	-	Needle Valve Only

\* Hydraulic hose is not stocked by KINZE® Repair Parts, but can be made available on a special order basis. Call for quote.

# ROW UNIT ASSEMBLY

CCU002/CCU011(CLT42a/CLT49)

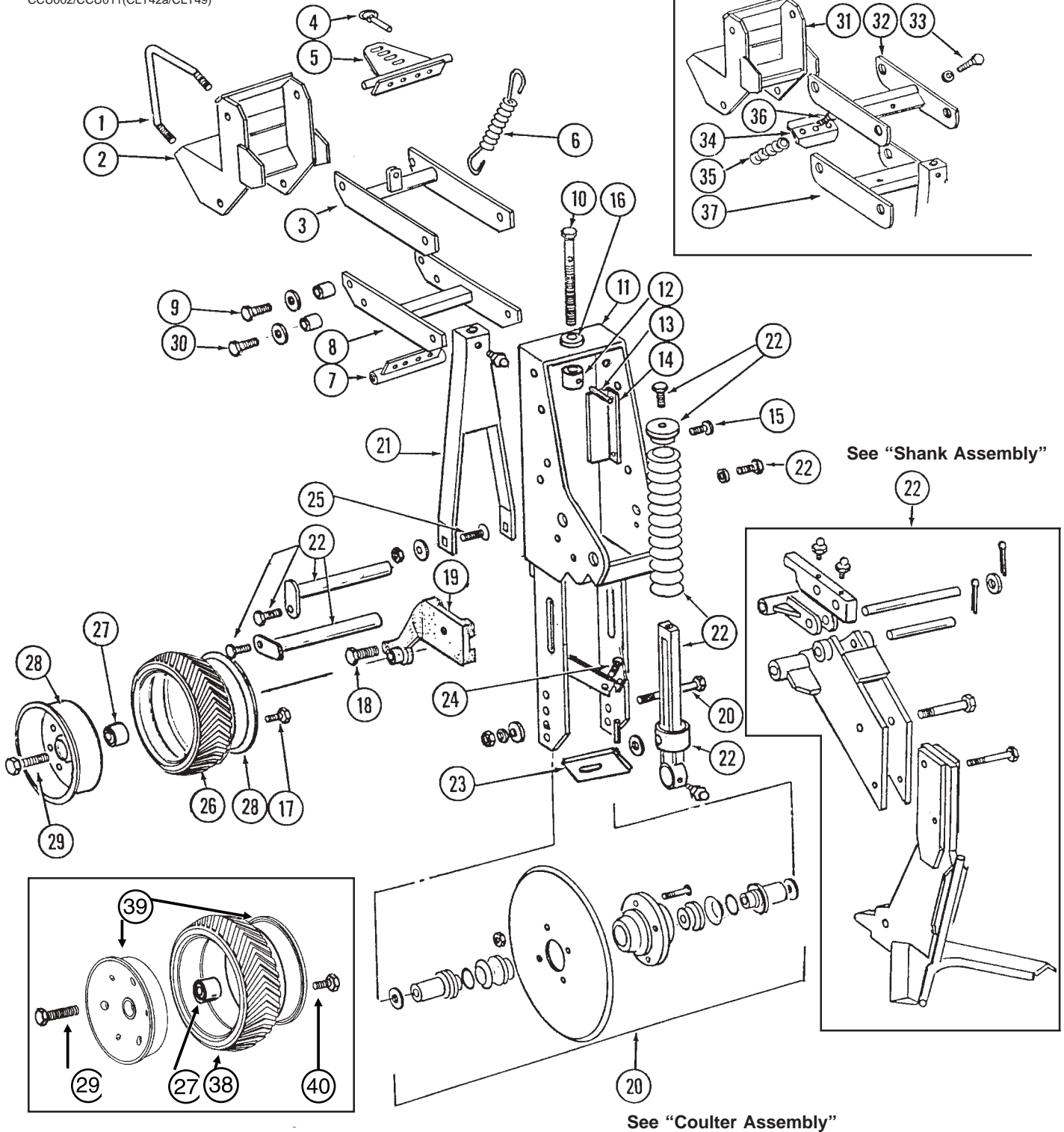

See "Shank Assembly"

See "Coulter Assembly"

ITEM	PART NO.	QTY.	DESCRIPTION
1.	GD8175	2	U-Bolt, 7" x 7" (Diamond) x 5/8"-11
	GD7805	4	Special Washer
	G10104	4	Lock Washer, 5/8"
	G10230	4	Hex Nut, 5/8"-11
	GA6558	1	Mount

# ROW UNIT ASSEMBLY

ITEM	PART NO.	QTY.	DESCRIPTION
3.	GA6557	1	Upper Parallel Arms
4.	GD2558	1	Lynch Pin, 1/4"
5.	GA6555	1	Upper Spring Anchor
6.	GD8249	4	Spring
7.	GA6554	1	Lower Spring Anchor
8.	GA6556	1	Lower Parallel Arms
9.	G10732	8	Hex Head Cap Screw, 5/8"-18 x 2"
	GD7805	8	Special Washer
	GB0218	8	Bushing
	G10412	8	Lock Nut, 5/8"-18
10.	GD8162	1	Adjusting Screw
11.	GA5821	1	Housing
12.	GD8170	1	Sleeve, 1 1/2"
13.	G10602	1	Spring Pin, 1/4" x 1 1/2"
14.	GD8776	1	Decal Mount
15.	G10001	2	Hex Head Cap Screw, 3/8"-16 x 1"
	G10229	2	Lock Washer, 3/8"
	G10101	2	Hex Nut, 3/8"-16
16.	G10224	1	Washer, 7 Gauge
17.	G10018	14	Hex Head Cap Screw, 5/16"-18 x 5/8"
	G10109	14	Lock Nut, 5/16"-18
18.	G10053	1	Hex Head Cap Screw, 1/2"-13 x 2 1/2"
	G10102	1	Hex Nut, 1/2"-13
19.	GB0221	1	Gauge Wheel Arm, L.H. (Shown)
	GB0222	1	Gauge Wheel Arm, R.H.
20.		-	See "Coulter Assembly", Page P16
21.	GA5828	1	Adjustment Fork W/Grease Fitting
	G10641	1	Grease Fitting, 1/8" NPT
22.		-	See "Shank Assembly", Pages P14 And P15
23.	GD1673	2	Scraper
24.	G10599	2	Carriage Bolt, 3/8"-16 x 1 1/4"
	G10203	2	Washer, 3/8" SAE
	G10229	2	Lock Washer, 3/8"
	G10101	2	Hex Nut, 3/8"-16
25.	G10392	2	Carriage Bolt, 5/8"-11 x 2 1/2"
	G10217	2	Washer, 5/8" USS
	G10730	2	Nylon Lock Nut, 5/8"-11
26.	GD9275	2	Tire, 4" x 12", Chevron Tread (Shown)
	GD8801	2	Tire, 4" x 12", Smooth, (Sub GD9275)
27.	GA6171	2	Bearing
28.	GD9276	4	Wheel Half (Metal)
29.	G10010	2	Hex Head Cap Screw, 5/8"-11 x 3"
	G10230	2	Lock Washer, 5/8"
30.	G10007	2	Hex Head Cap Screw, 5/8"-11 x 1 1/2"
	GD7805	2	Special Washer
	GB0218	2	Bushing
31.	GA5820	1	Mount
32.	GA5818	1	Upper Parallel Arms
33.	G10010	1	Hex Head Cap Screw, 5/8"-11 x 3"
	G10217	1	Washer, 5/8" USS
34.	GA6306	1	Spring Plate
35.	GA2068	2	Spring W/Plug
36.	G10017	2	Hex Head Cap Screw, 1/2"-13 x 1 1/2"
37.	GA5819	1	Lower Parallel Arms
38.	GD10442	2	Tire, 4" x 12", Chevron Tread
39.	GD10443	4	Wheel Half (Plastic)
40.	G10638	12	Hex Head Cap Screw, 1/4"-20 x 2"
	G10211	24	Washer, 1/4" SAE
	G10110	12	Lock Nut, 1/4"-20
A.	GA6574	2	Gauge Wheel Complete (Items 17 And 26-28)
	GA7350	2	Gauge Wheel Complete (Items 27, 29 And 38-40)

# SHANK ASSEMBLY

CCU002/CCU003(CLT43a)

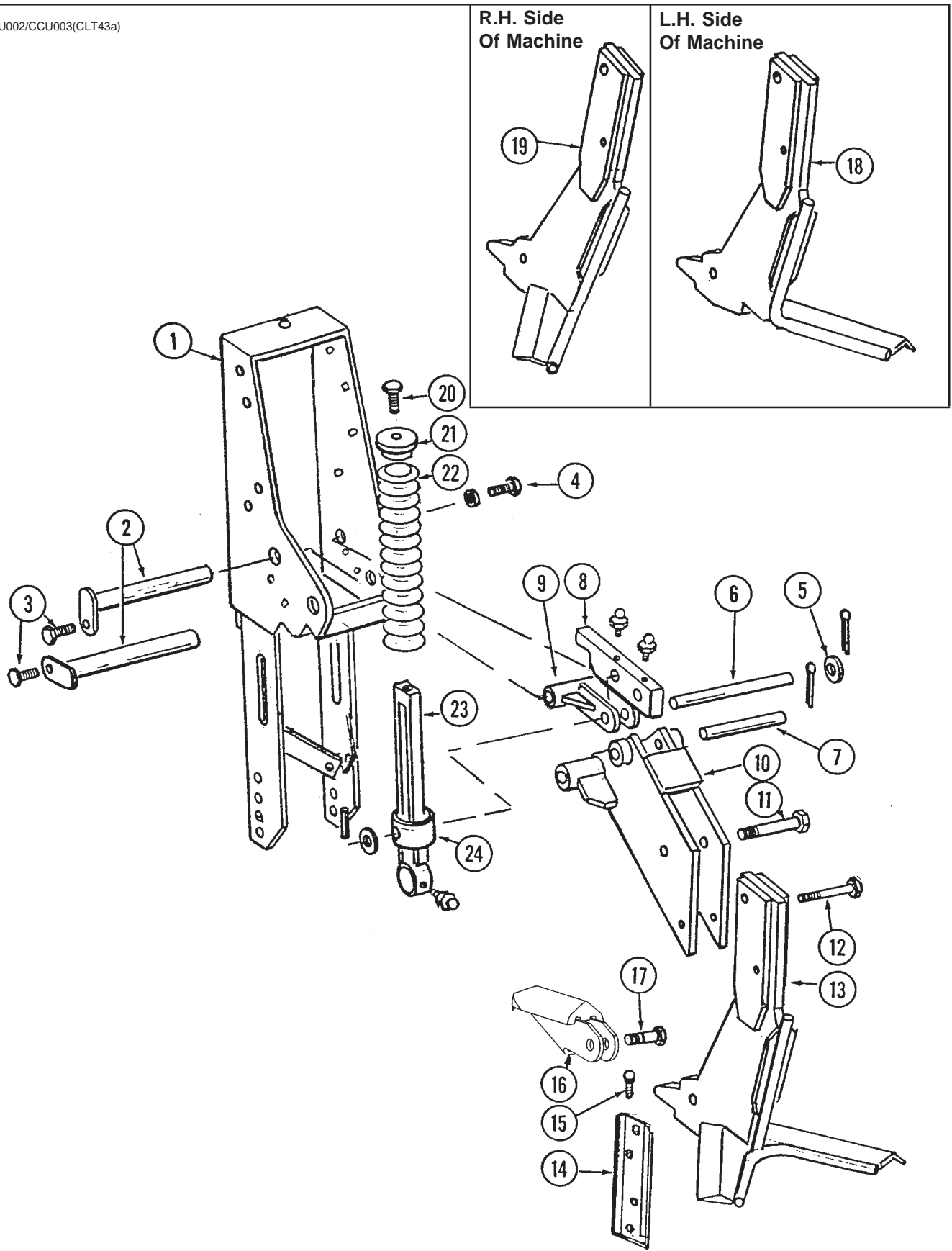

# SHANK ASSEMBLY

ITEM	PART NO.	QTY.	DESCRIPTION
1.		-	See "Row Unit Assembly", Pages P12 And P13
2.	GA6129	2	Hammer Strap W/Grease Fitting
	G10641	2	Grease Fitting, 1/8" NPT
3.	G10037	2	Hex Head Cap Screw, 1/2"-13 x 1 1/4"
	G10228	2	Lock Washer, 1/2"
	G10102	2	Hex Nut, 1/2"-13
4.	G10428	2	Hex Head Cap Screw, 5/8"-11 x 3/4"
	GD7805	2	Special Washer
5.	G10082	2	Washer, 1" SAE
6.	GD8227	1	Pin, 1" x 9 1/2"
	G10459	2	Cotter Pin, 3/16" x 1 1/2"
7.	GD8228	1	Pin, 1" x 3 1/2"
	G10459	2	Cotter Pin, 3/16" x 1 1/2"
8.	GA6130	1	Link Assembly W/Grease Fittings
	G10641	2	Grease Fitting, 1/8" NPT
9.	GB0224	1	Link
10.	GA5854	1	Shank Mount
11.	G10009	1	Hex Head Cap Screw, 5/8"-11 x 2 1/2"
	G10107	1	Lock Nut, 5/8"-11
12.	G10049	1	Hex Head Cap Screw, 3/8"-16 x 2 1/2" (Shear Bolt)
	G10108	1	Lock Nut, 3/8"-16
13.	GA6159	1	Shank W/Tube
14.	GD8612	2	Double Edge Share, 17" (432mm), 15" (381mm) Cutting Edge
	GD8613	2	Double Edge Share, 19" (483mm), 16 1/2" (419mm) Cutting Edge
	GD8614	2	Double Edge Share, 21" (533mm), 18" (457mm) Cutting Edge
	GD8615	2	Double Edge Share, 25" (635mm), 21 1/2" (546mm) Cutting Edge
	GD8616	2	Double Edge Share, 27" (686mm), 23" (584mm) Cutting Edge
	GD8931	2	Double Edge Share, Hard Surface, 17" (432mm), 15" (381mm) Cutting Edge
	GD8932	2	Double Edge Share, Hard Surface, 19" (483mm), 16 1/2" (419mm) Cutting Edge
	GD8933	2	Double Edge Share, Hard Surface, 21" (533mm), 18" (457mm) Cutting Edge
	GD8934	2	Double Edge Share, Hard Surface, 25" (635mm), 21 1/2" (546mm) Cutting Edge
	GD8935	2	Double Edge Share, Hard Surface, 27" (686mm), 23" (584mm) Cutting Edge
15.	G10593	4	Plow Bolt, 3/8"-16 x 1", No. 3
	G10622	4	Flange Nut, 3/8"-16
16.	GA6974	1	Shank Point, Style B (Shown)
	GA6035	-	Shank Point, Style A (Sub GA6974)
17.	G10039	1	Hex Head Cap Screw, 1/2"-13 x 1 3/4"
	G10111	1	Lock Nut, 1/2"-13
18.	GA6164	1	End Shank W/Tube, R.H.
19.	GA6163	1	End Shank W/Tube, L.H.
20.	G10009	2	Hex Head Cap Screw, 5/8"-11 x 2 1/2"
21.	GB0196	2	Washer
22.	GD7831	2	Reset Spring
23.	GA5823	2	Spring Guide W/Grease Fitting
	G10641	2	Grease Fitting, 1/8" NPT
24.	GB0220	2	Spring Seat
A.	G7217X	-	Hardware Bag For Mounting Shares, 2 Rows, Includes: (8)G10593, (8)G10622

# COULTER ASSEMBLY

CCU002(CLT44)

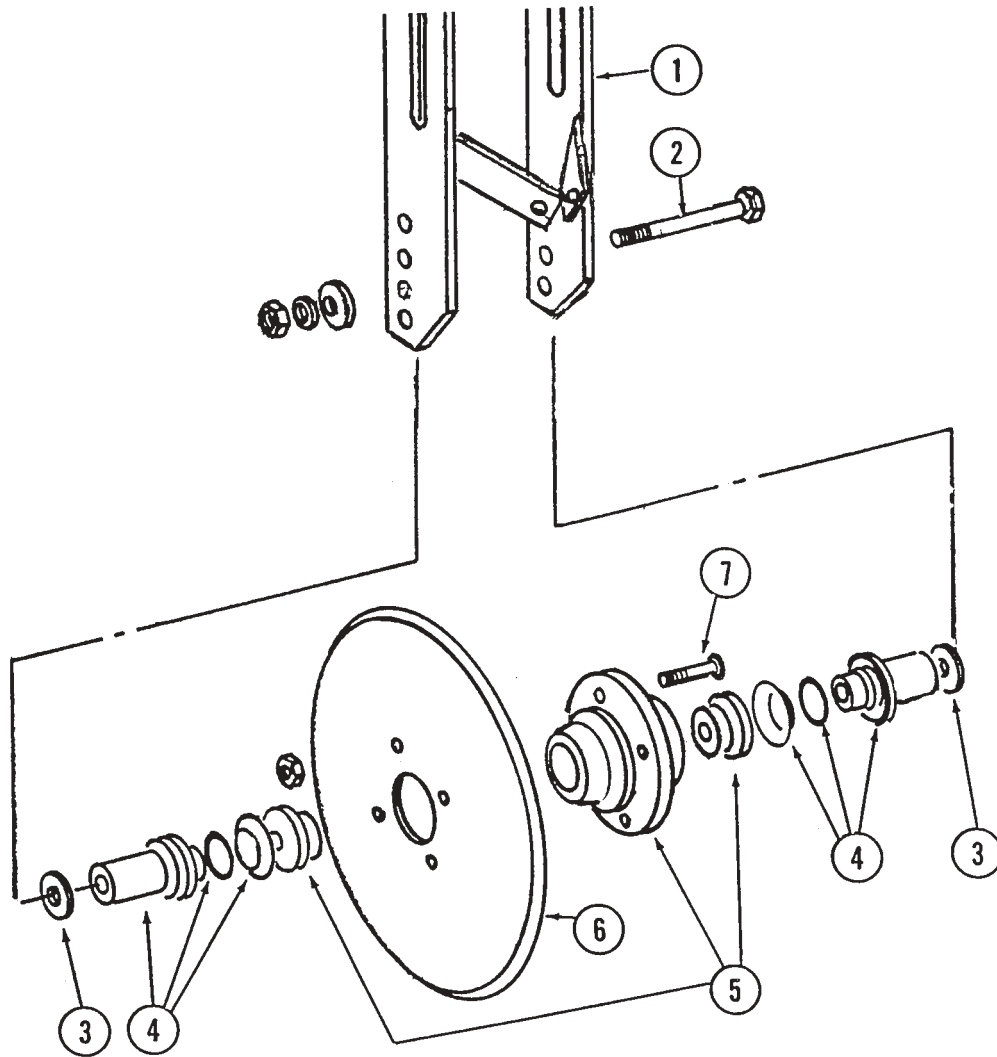

ITEM	PART NO.	QTY.	DESCRIPTION
1.		-	See "Row Unit Assembly", Pages P12 And P13
2.	G10341	1	Hex Head Cap Screw, $\frac{5}{8}$ "-11 x 8"
	G10205	1	Washer, $\frac{5}{8}$ " SAE
	G10230	1	Lock Washer, $\frac{5}{8}$ "
	G10104	1	Hex Nut, $\frac{5}{8}$ "-11
3.	G10205	2	Washer, $\frac{5}{8}$ " SAE
4.	GB0226	2	Adapter W/O-Ring And Spring Washer
	GD8844	2	O-Ring
	GD8843	2	Spring Washer
5.	GA5640	1	Hub W/Bearings And Grease Fitting
	GA5622	2	Bearing
	G10640	1	Grease Fitting, $\frac{1}{4}$ "-20
6.	GD8226	1	Coultter, 18"
7.	G10574	4	Carriage Bolt, $\frac{1}{2}$ "-13 x 1 $\frac{1}{4}$ "
	G10111	4	Lock Nut, $\frac{1}{2}$ "-13

# COIL ANHYDROUS SHANK WITH KNIFE MOUNT

CCU009(CLT45)

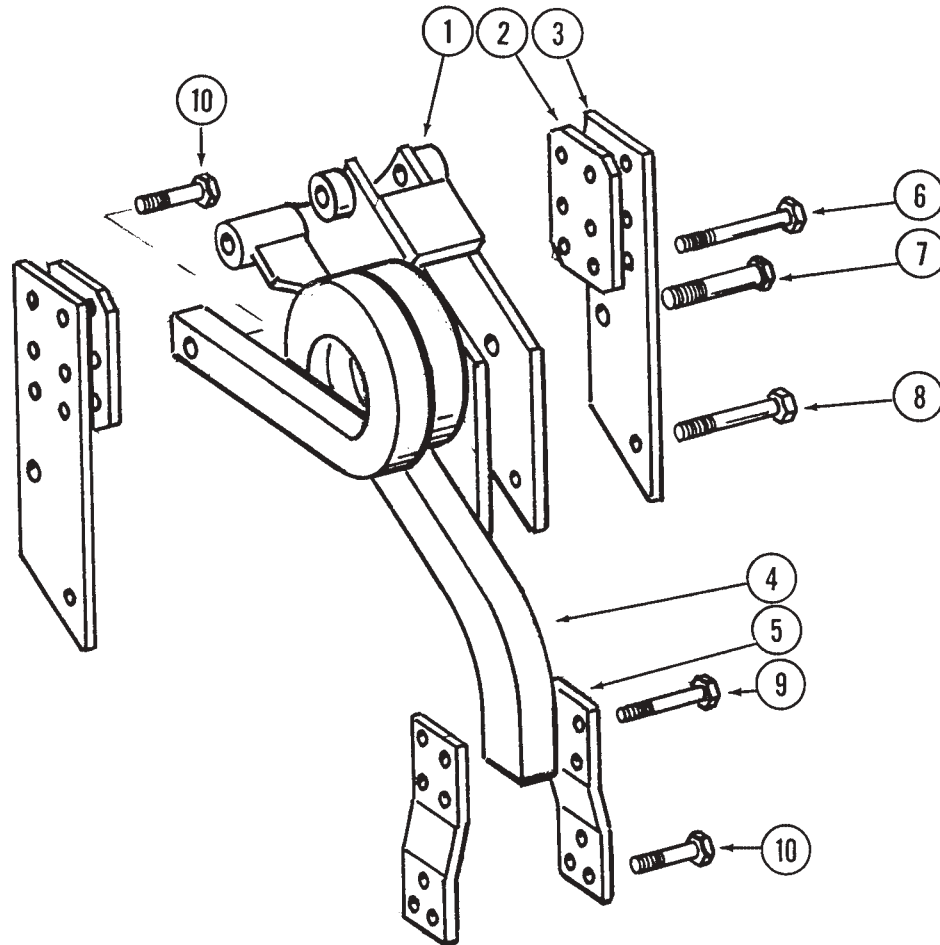

ITEM	PART NO.	QTY.	DESCRIPTION
1.		-	See "Shank Assembly", Pages P14 And P15
2.	GD9126	2	Spacer
3.	GD9125	2	Mount
4.	GD9274	1	Coil Shank
5.	GD2071	2	Plate
6.	G10585	4	Hex Head Cap Screw, 1/2"-13 x 3 1/4"
	G10111	4	Lock Nut, 1/2"-13
7.	G10013	1	Hex Head Cap Screw, 5/8"-11 x 3 1/2"
	G10107	1	Lock Nut, 5/8"-11
8.	G10061	1	Hex Head Cap Screw, 3/8"-16 x 3 1/2" (Shear Bolt)
	G10108	1	Lock Nut, 3/8"-16
9.	G10397	4	Hex Head Cap Screw, 1/2"-13 x 2 3/4"
	G10111	4	Lock Nut, 1/2"-13
10.	G10016	3	Hex Head Cap Screw, 1/2"-13 x 2"
	G10111	3	Lock Nut, 1/2"-13

# CUT-AWAY WEEDING DISCS

CCU003(CLT46a)

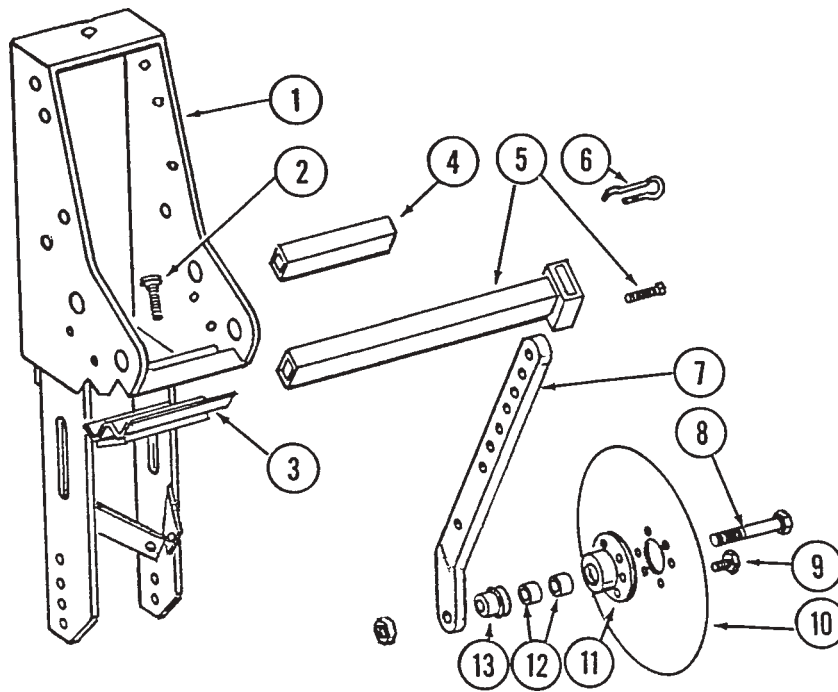

ITEM	PART NO.	QTY.	DESCRIPTION
1.		-	See "Row Unit Assembly", Pages P12 And P13
2.	G10667	2	Carriage Bolt, $\frac{5}{8}$ "-11 x 5"
	G10107	2	Lock Nut, $\frac{5}{8}$ "-11
3.	GA6081	1	Clamp
4.	GD0750-08	1	Tube, 6" (Used On End Rows Only)
5.	GA7866	-	Mount W/Set Screw
	G10666	2	Set Screw, $\frac{5}{8}$ "-11 x 1 $\frac{1}{2}$ "
6.	GD8819	1	Clinch Pin
7.	GD8234	1	Bar, R.H. (Shown)
	GD8235	1	Bar, L.H.
8.	G10318	1	Hex Head Cap Screw, $\frac{5}{8}$ "-11 x 4 $\frac{1}{2}$ "
	G10107	1	Hex Nut, $\frac{5}{8}$ "-11
9.	G10572	6	Truss Head Slotted Machine Screw, $\frac{5}{16}$ "-18 x $\frac{7}{8}$ "
	G10106	6	Hex Nut, $\frac{5}{16}$ "-18
10.	GD8818	1	Disc, 14" (356mm)
11.	GB0195	1	Hub, 6 Bolt
12.	GA2014	2	Bearing
13.	GD8817	1	Spacer

# RIDGING ATTACHMENT

CCU005(CLT9a)

## 30" (76.2 cm) Row Machine

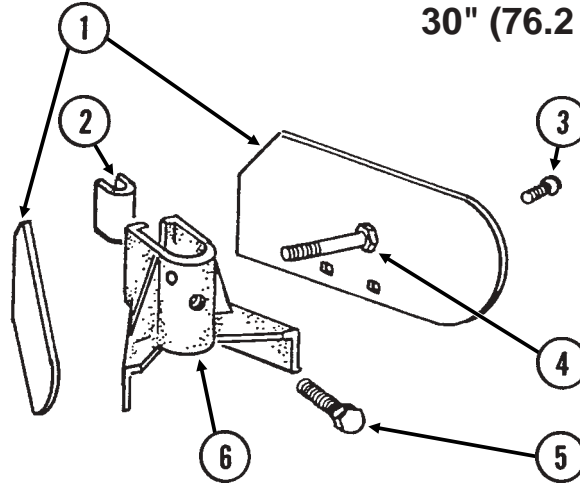

## Wide Row (91-101cm) Machines

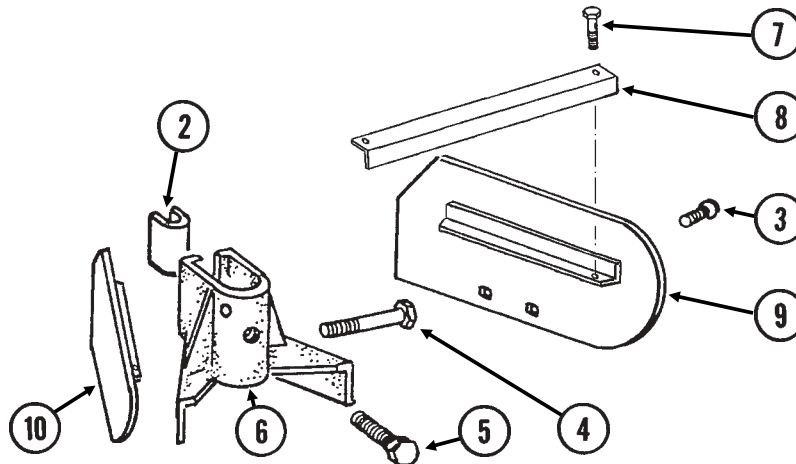

ITEM	PART NO.	QTY.	DESCRIPTION
1.	GD8738	2	Ridge Blade, (13 3/4" [349mm] Total Length)
2.	GD11234	1	Strap
3.	G10305	4	Carriage Bolt, 3/8"-16 x 1"
	G10210	4	Washer, 3/8" USS
	G10229	4	Lock Washer, 3/8"
	G10101	4	Hex Nut, 3/8"-16
4.	G10061	1	Hex Head Cap Screw, 3/8"-16 x 3 1/2"
	G10229	1	Lock Washer, 3/8"
	G10101	1	Hex Nut, 3/8"-16
5.	G10005	1	Hex Head Cap Screw, 5/8"-11 x 1 3/4"
6.	GB0225	1	Mount
7.	G10001	2	Hex Head Cap Screw, 3/8"-16 x 1"
	G10210	2	Washer, 3/8" USS
	G10229	2	Lock Washer, 3/8"
	G10101	2	Hex Nut, 3/8"-16
8.	GD10973	1	Spreader
9.	GA7968	1	Ridge Blade, R.H. (17 3/4" [451mm] Total Length)
10.	GA7969	1	Ridge Blade, L.H. (17 3/4" [451mm] Total Length)

# ROTARY HOE/ROLLING DISC CROP SHIELD WITH MOUNTING SUPPORT

CCU004(CLT10)

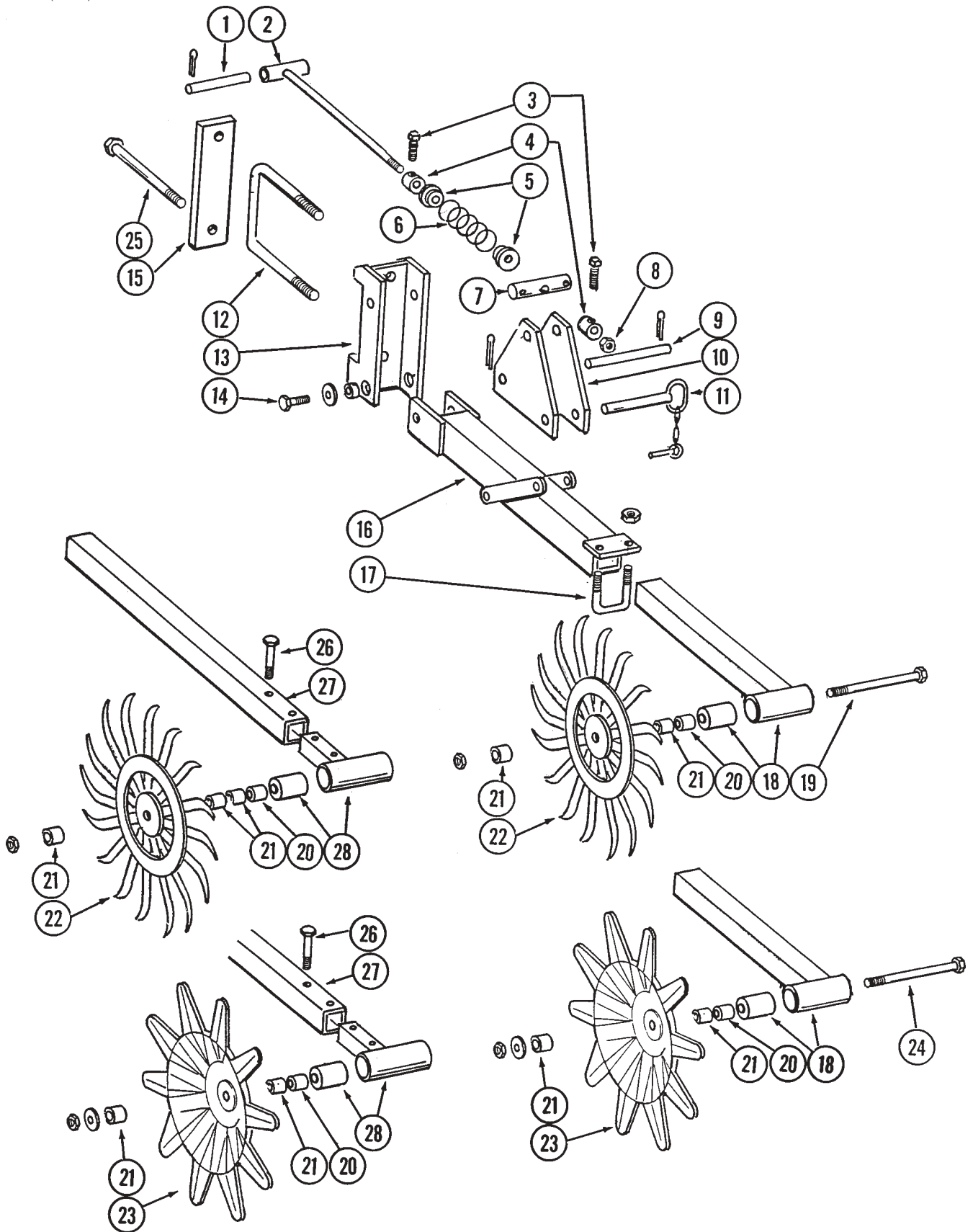

# ROTARY HOE/ROLLING DISC CROP SHIELD WITH MOUNTING SUPPORT

---

ITEM	PART NO.	QTY.	DESCRIPTION
1.	GD8712	1	Pin
	G10459	2	Cotter Pin, $\frac{3}{16}$ " x 1 $\frac{1}{2}$ "
2.	GA6082	1	Spring Arm
3.	G10759	2	Hex Head Cap Screw, $\frac{5}{8}$ "-11 x 1 $\frac{1}{4}$ "
4.	GB0242	2	Set Collar
5.	GB0212	2	Spring Seat
6.	GD8308	1	Spring
7.	GD8715	1	Pin
	G10462	2	Cotter Pin, $\frac{3}{16}$ " x 2"
8.	G10107	1	Lock Nut, $\frac{5}{8}$ "-11
9.	GD8714	1	Pin
	G10459	2	Cotter Pin, $\frac{3}{16}$ " x 1 $\frac{1}{2}$ "
10.	GA6079	1	Mount
11.	GA6189	1	Hitch Pin
12.	GD1114	1	U-Bolt, 7" x 7" x $\frac{5}{8}$ "-11
	G10230	2	Lock Washer, $\frac{5}{8}$ "
	G10104	2	Hex Nut, $\frac{5}{8}$ "-11
13.	GA6084	1	Mount
14.	G10005	2	Hex Head Cap Screw, $\frac{5}{8}$ "-11 x 1 $\frac{3}{4}$ "
	GB0218	2	Bushing
	GD7805	2	Special Washer
	G10107	2	Lock Nut, $\frac{5}{8}$ "-11
15.	GD1908	1	Bracket
16.	GA6085	1	Receiver
17.	GD2721	1	U-Bolt, 2" x 2" x $\frac{1}{2}$ "-13
	G10228	2	Lock Washer, $\frac{1}{2}$ "
	G10102	2	Hex Nut, $\frac{1}{2}$ "-13
18.	GA6186	1	Tube W/Bearing <b>(Sub [1] GA6756, [1] GD9607, [2] G10379, [2] G10111)</b>
	GA6171	1	Bearing
19.	G10668	1	Hex Head Cap Screw, $\frac{5}{8}$ "-11 x 11"
	G10107	1	Lock Nut, $\frac{5}{8}$ "-11
20.	GD7817-03	2	Spacer, 1"
21.	GD7817-01	4-6	Spacer, $\frac{3}{4}$ "
22.	GA6316	2	Rotary Hoe Wheel, 21 $\frac{1}{2}$ "
23.	GA6564	2	Rolling Disc Wheel, 19 $\frac{5}{8}$ "
24.	G10093	1	Hex Head Cap Screw, $\frac{5}{8}$ "-11 x 8 $\frac{1}{2}$ "
	G10217	2	Washer, $\frac{5}{8}$ " USS
	G10107	1	Lock Nut, $\frac{5}{8}$ "-11
25.	G10152	-	Hex Head Cap Screw, $\frac{5}{8}$ "-11 x 9"
	G10232	-	Lock Washer, $\frac{5}{8}$ "
	G10104	-	Hex Nut, $\frac{5}{8}$ "-11
26.	G10397	2	Hex Head Cap Screw, $\frac{1}{2}$ "-13 x 2 $\frac{3}{4}$ "
	G10111	2	Lock Nut
27.	GD9607	1	Tube
28.	GA6756	1	Arm W/Bearing
	GA6171	1	Bearing

# LIQUID FERTILIZER DRIVE WHEEL ASSEMBLY

CCU007/HTA014(CLT16a)

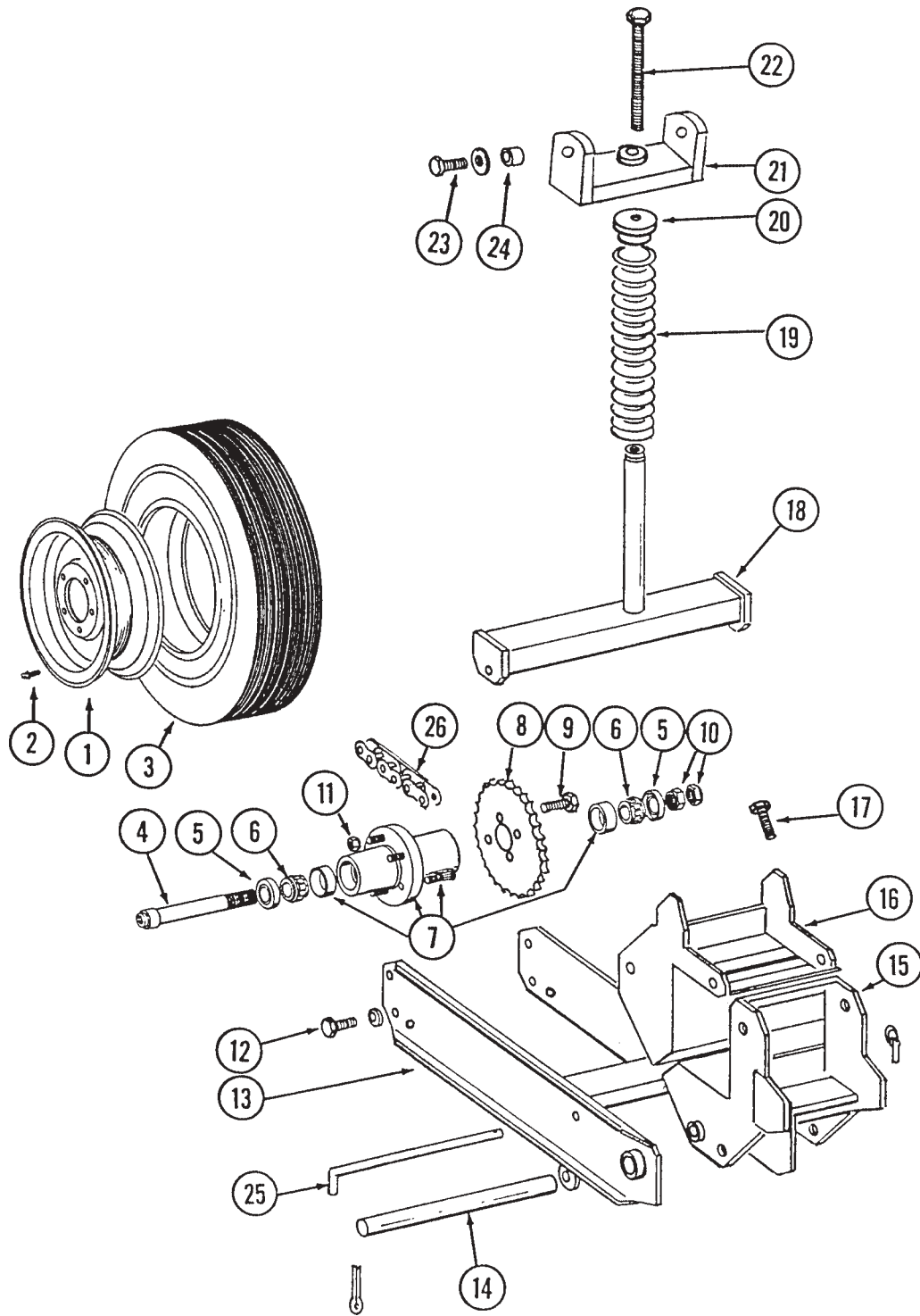

# LIQUID FERTILIZER DRIVE WHEEL ASSEMBLY

---

ITEM	PART NO.	QTY.	DESCRIPTION
1.	GA0241	1	Wheel, 5" x 15"
2.	GD1166	1	Valve Stem
3.	GD0844	1	Tire, 7.60" x 15", 4 Ply (Specify Brand)
4.	GA2559	1	Spindle
5.	GA0252	2	Seal
6.	GA0251	2	Bearing
7.	GA0547	1	Hub W/Cups And Studs, 5 Bolt
	GR0190	2	Cup
	GR0204	5	Stud
8.	G2500-84	1	Sprocket, 48 Tooth
9.	G10019	4	Hex Head Cap Screw, $\frac{5}{16}$ "-18 x 1"
	G10232	4	Lock Washer, $\frac{5}{16}$ "
10.	GD0831	2	Shoulder Nut, 1 $\frac{1}{4}$ "-12 UNF-2A
11.	GR0267	5	Lug Nut, $\frac{1}{2}$ "-20
12.	G10026	2	Hex Head Cap Screw, $\frac{3}{4}$ "-10 x 2"
	G10231	2	Lock Washer, $\frac{3}{4}$ "
13.	GA6307	1	Arm W/Grease Fittings
	G10641	2	Grease Fitting, $\frac{1}{8}$ " NPT
14.	GD2681	1	Pin, 1 $\frac{1}{4}$ " x 13 $\frac{1}{2}$ "
	G10460	2	Cotter Pin, $\frac{1}{4}$ " x 2"
15.	GA6315	1	Arm Mount (Used With GA5820 Mount - See "Row Unit Assembly")
	GA6751	1	Arm Mount (Used With GA6558 Mount - See "Row Unit Assembly")
16.		1	Mount (See "Row Unit Assembly", Pages P12 And P13)
17.	G10013	4	Hex Head Cap Screw, $\frac{5}{8}$ "-11 x 3 $\frac{1}{2}$ "
	GD7805	8	Special Washer
	G10230	4	Lock Washer, $\frac{5}{8}$ "
	G10104	4	Hex Nut, $\frac{5}{8}$ "-11
18.	GA6309	1	Spring Guide
19.	GD7831	1	Spring
20.	GB0196	1	Spring Seat
21.	GA6308	1	Spring Mount
22.	G10068	1	Hex Head Cap Screw, $\frac{5}{8}$ "-11 x 6"
	GD7805	1	Special Washer
23.	G10008	2	Hex Head Cap Screw, $\frac{5}{8}$ "-11 x 2"
	GD7805	4	Special Washer
	G10107	2	Lock Nut, $\frac{5}{8}$ "-11
24.	GB0218	2	Bushing
25.	GD8917	1	"L" Pin, 12 $\frac{3}{8}$ "
	GD2558	1	Lynch Pin, $\frac{1}{4}$ "
26.	G3200-79	1	Chain, No. 2050, 79 Pitch Including Connector Link And Offset Link
	GR0195	1	Connector Link, No. 2050
	GR0200	1	Offset Link, No. 2050

# LIQUID FERTILIZER PUMP MOUNT ASSEMBLY

CCU002/CCU0077/LFC026(CLT17/FF65)

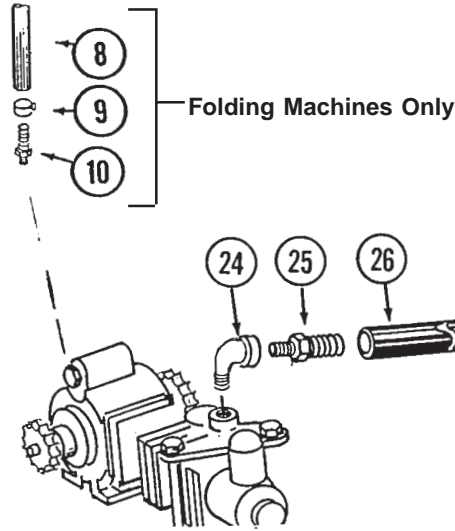
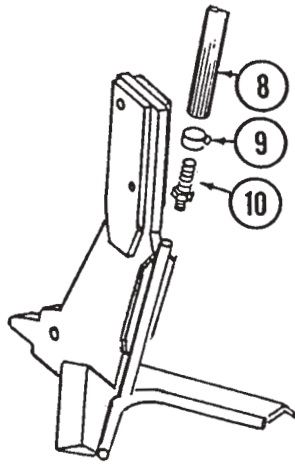

8-16 Row Machines

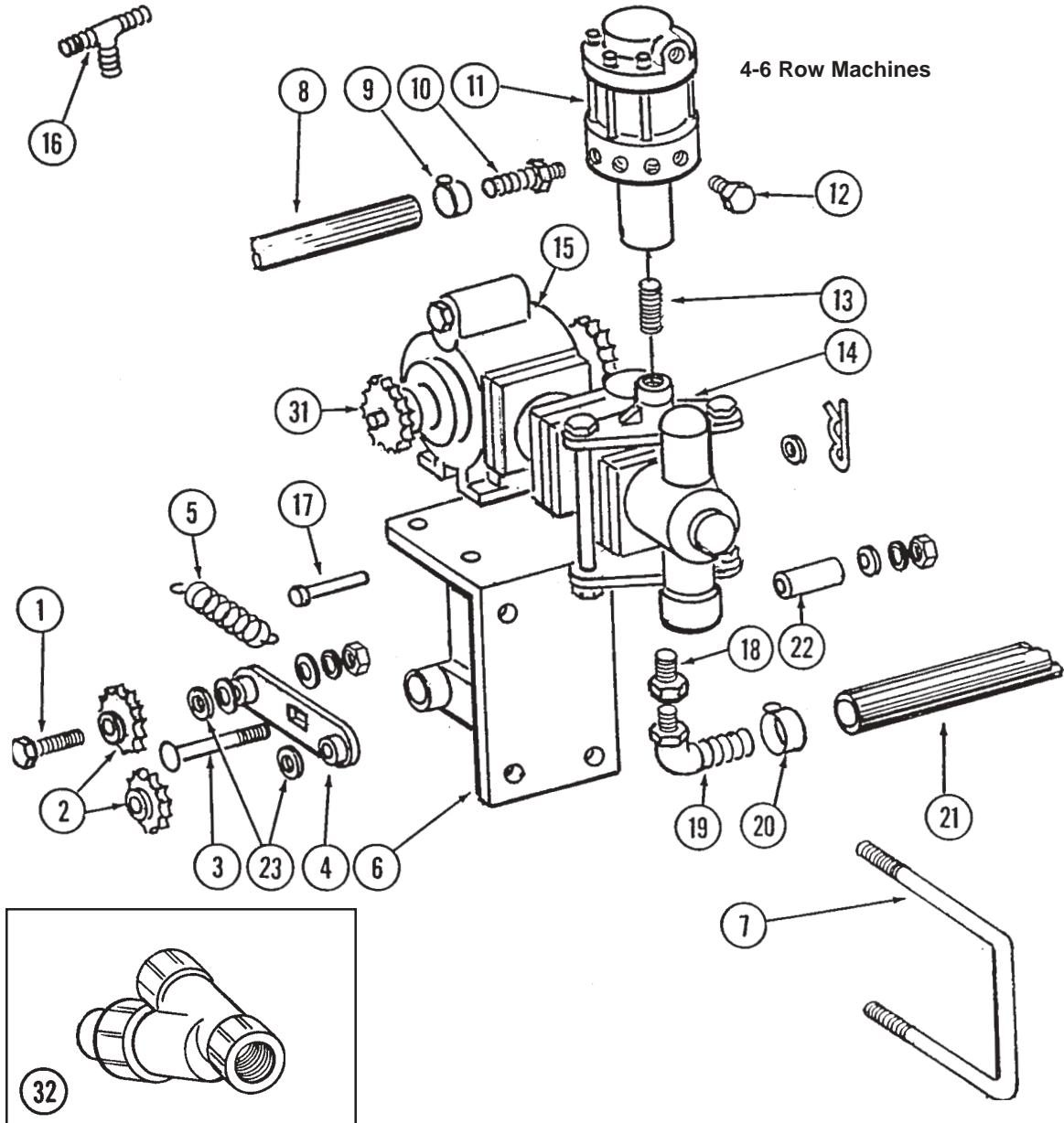
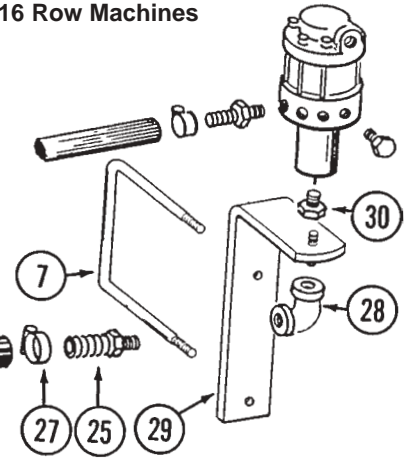

4-6 Row Machines

# LIQUID FERTILIZER PUMP MOUNT ASSEMBLY

ITEM	PART NO.	QTY.	DESCRIPTION
1.	G10009	2	Hex Head Cap Screw, $\frac{5}{8}$ "-11 x 2 $\frac{1}{2}$ "
	G10205	4	Washer, $\frac{5}{8}$ " SAE
	G10230	2	Lock Washer, $\frac{5}{8}$ "
	G10104	2	Hex Nut, $\frac{5}{8}$ "-11
2.	GA0262	2	Idler Sprocket W/Bearing, 15 Tooth
3.	G10683	1	Carriage Bolt, $\frac{5}{8}$ "-11 x 4 $\frac{1}{2}$ "
	G10205	1	Washer, $\frac{5}{8}$ " SAE
	G10235	3	Machine Bushing
	G10230	1	Lock Washer, $\frac{5}{8}$ "
	G10104	1	Hex Nut, $\frac{5}{8}$ "-11
4.	GD8851	1	Idler Bracket
5.	GD0829	1	Spring
6.	GA6310	1	Mount W/Grease Fitting
	G10640	1	Grease Fitting, $\frac{1}{4}$ "-20
7.	GD1114	2	U-Bolt, 7" x 7" x $\frac{5}{8}$ "-11
	G10230	4	Lock Washer, $\frac{5}{8}$ "
	G10104	4	Hex Nut, $\frac{5}{8}$ "-11
8.	G4300-14	-	Clear Hose, $\frac{7}{16}$ " x 150' (4572 cm), 4, 6 And 8 Row
	G4300-15	-	Clear Hose, $\frac{7}{16}$ " x 300' (9144 cm), 10, 12 And 16 Row
9.	G10673	-	Hose Clamp, No. 8
10.	GD8816	-	Hose Barb
11.		-	See "Liquid Fertilizer Flow Divider", Pages P30-P33
12.	G10292	8	Plug, $\frac{1}{4}$ " NPT
13.	G10389	1	Pipe Nipple, $\frac{3}{4}$ " NPT
14.		-	See "Liquid Fertilizer Piston Pump (Cylinder Assembly)", Pages P28 And P29
15.		-	See "Liquid Fertilizer Piston Pump (Crankcase Assembly)", Pages P26 And P27
16.	G10679	1	Hose Barb Tee, $\frac{1}{2}$ "
17.	G10478	1	Clevis Pin, $\frac{5}{16}$ "
	G10409	1	Retaining Ring
	G10669	1	Hair Pin Clip
18.	G10615	1	Reducing Bushing, 1 $\frac{1}{2}$ " to 1 $\frac{1}{4}$ "
19.	G10629	1	Elbow, 90°, 1 $\frac{1}{4}$ "
20.	G10674	-	Hose Clamp, No. 24
21.	G4200-01	-	Hose, 1 $\frac{1}{4}$ " x 22' (671 cm), 4, 6 And 8 Row
	G4200-03	-	Hose, 1 $\frac{1}{4}$ " x 32' (975 cm), 10, 12 And 16 Row
22.	GD3180-10	1	Sleeve, 3 $\frac{1}{4}$ "
23.	GD6171	2	Sleeve, $\frac{3}{8}$ "
24.	G10735	1	Street Elbow, $\frac{3}{4}$ " NPT
25.	G10734	2	Hose Barb, $\frac{3}{4}$ "
26.	G4205-10	-	Hose, $\frac{3}{4}$ " x 200" (508 cm), 8, 10, 12 And 16 Row
27.	G10675	2	Hose Clamp, No. 20
28.	G10733	1	Elbow, $\frac{3}{4}$ " NPT
29.	GA6527	1	Support
30.	G10737	1	Reducing Bushing, $\frac{3}{4}$ " x 1 $\frac{1}{4}$ " NPT (16 Row Only)
31.	GR1146	1	Sprocket, 18 Tooth
32.	GA3893	1	Strainer Complete
	GR0880	-	Screen
	GR0881	-	Gasket
	GR0882	-	"Y" Body
	GR0883	-	End Cap

# LIQUID FERTILIZER PISTON PUMP (Crankcase Assembly)

JB-L4400-991/CCU007(PT38)

## John Blue® Model L-4405

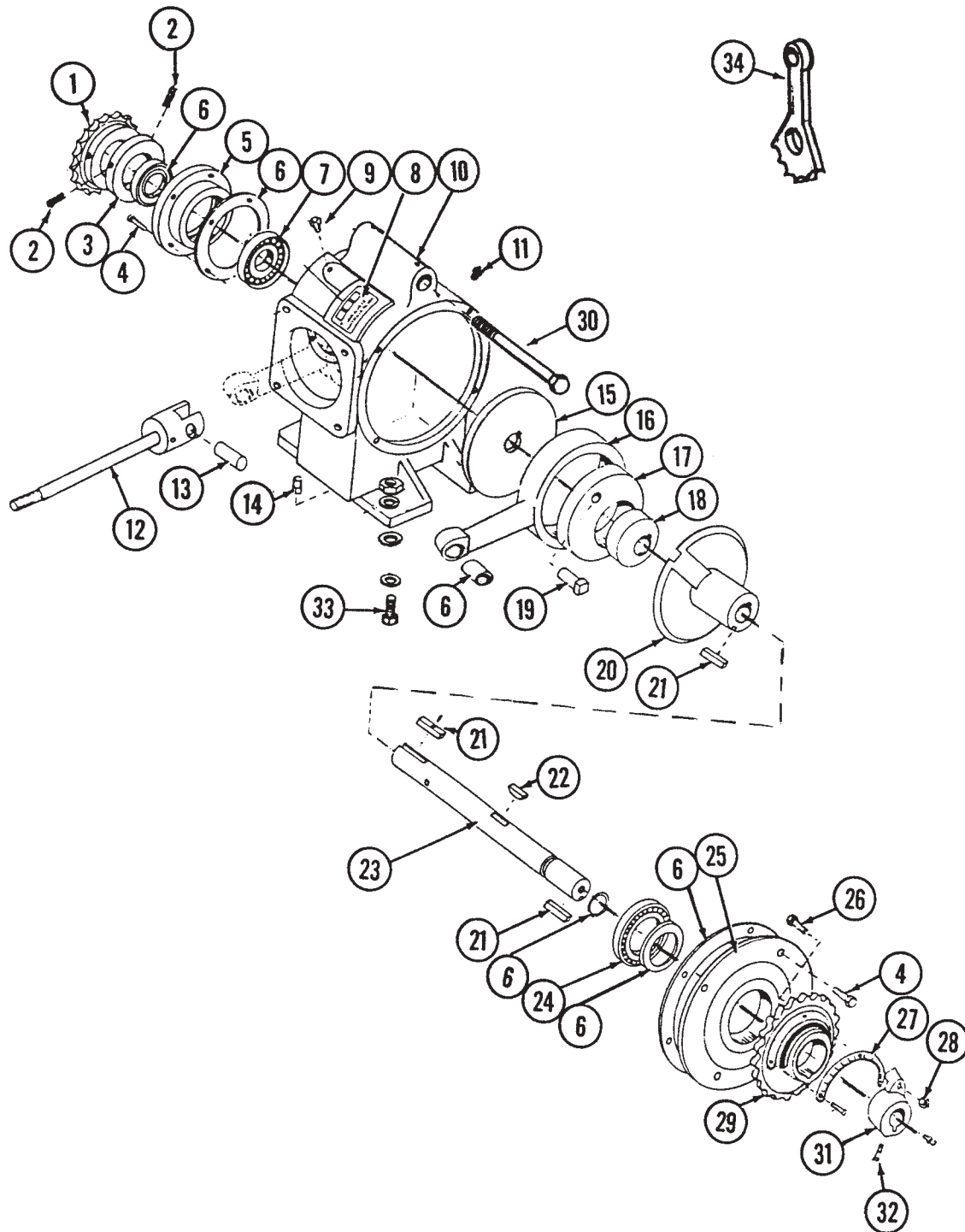

# LIQUID FERTILIZER PISTON PUMP (Crankcase Assembly)

ITEM	PART NO.	QTY.	DESCRIPTION
1.		-	See "Liquid Fertilizer Pump Mount Assembly", Pages P24 And P25
2.	G10688	2	Hex Socket Head Set Screw, $\frac{3}{8}$ "-16 x $\frac{5}{8}$ "
3.	GR1147	1	Spacer
4.	G10019	4	Hex Head Cap Screw, $\frac{5}{16}$ "-18 x 1"
5.	GR1102	1	Housing
6.	GR1173	-	Repair Kit, Also Includes Item 5 On "Liquid Fertilizer Piston Pump (Cylinder Assembly)" Pages P28 And P29
7.	GR1104	1	Bearing
8.	GR1105	1	Name Plate
9.	G10054	2	Hex Head Cap Screw, $\frac{5}{16}$ "-18 x $\frac{1}{2}$ "
10.	GR1106	1	Crankcase
11.	GR1107	1	Vent Plug
12.		-	See "Liquid Fertilizer Piston Pump (Cylinder Assembly)", Pages P28 And P29
13.		-	See "Liquid Fertilizer Piston Pump (Cylinder Assembly)", Pages P28 And P29
14.	GR1123	3	Plug
15.	GR1108	1	Disc
16.	GR1109	1	Connecting Rod
17.	GR1110	1	Large Eccentric
18.	GR1111	1	Small Eccentric
19.	GR1120	1	Eccentric Pin
20.	GR1119	1	Sleeve
21.	GR1118	3	Setting Arm Key
22.	GR1112	1	Woodruff Key
23.	GR1148	1	Crankshaft
24.	GR1116	1	Bearing
25.	GR1166	1	Cover Plate
26.	GR1167	1	Square Head Bolt, $\frac{3}{8}$ "-16 x 1 $\frac{3}{4}$ "
27.	GR1168	1	Scale
28.	G10108	1	Lock Nut, $\frac{3}{8}$ "-16
29.	GR1114	1	Flange
30.	G10318	1	Hex Head Cap Screw, $\frac{5}{8}$ "-11 x 4 $\frac{1}{2}$ "
	G10104	1	Hex Nut, $\frac{5}{8}$ "-11
31.	GR1165	1	Arm
32.	G10693	4	Hex Socket Head Set Screw, $\frac{5}{16}$ "-18 x $\frac{3}{8}$ "
33.	G10003	4	Hex Bolt, $\frac{3}{8}$ "-16 x 1 $\frac{1}{2}$ "
	GR1122	4	Mounting Pad
	G10210	8	Washer, $\frac{3}{8}$ " USS
	G10229	4	Lock Washer, $\frac{3}{8}$ "
	G10101	4	Hex Nut, $\frac{3}{8}$ "-16
34.	GR1100	1	Adjustment Wrench
A.	GA6154	1	Piston Pump Complete (L-4405), Includes Crankcase (Items 2-34 On This page) And Cylinder (Items 1-22 On Pages P28 And P29) Assemblies

# LIQUID FERTILIZER PISTON PUMP (Cylinder Assembly)

JB-L4400-991/SKH007(PT39)

John Blue® Model L-4405

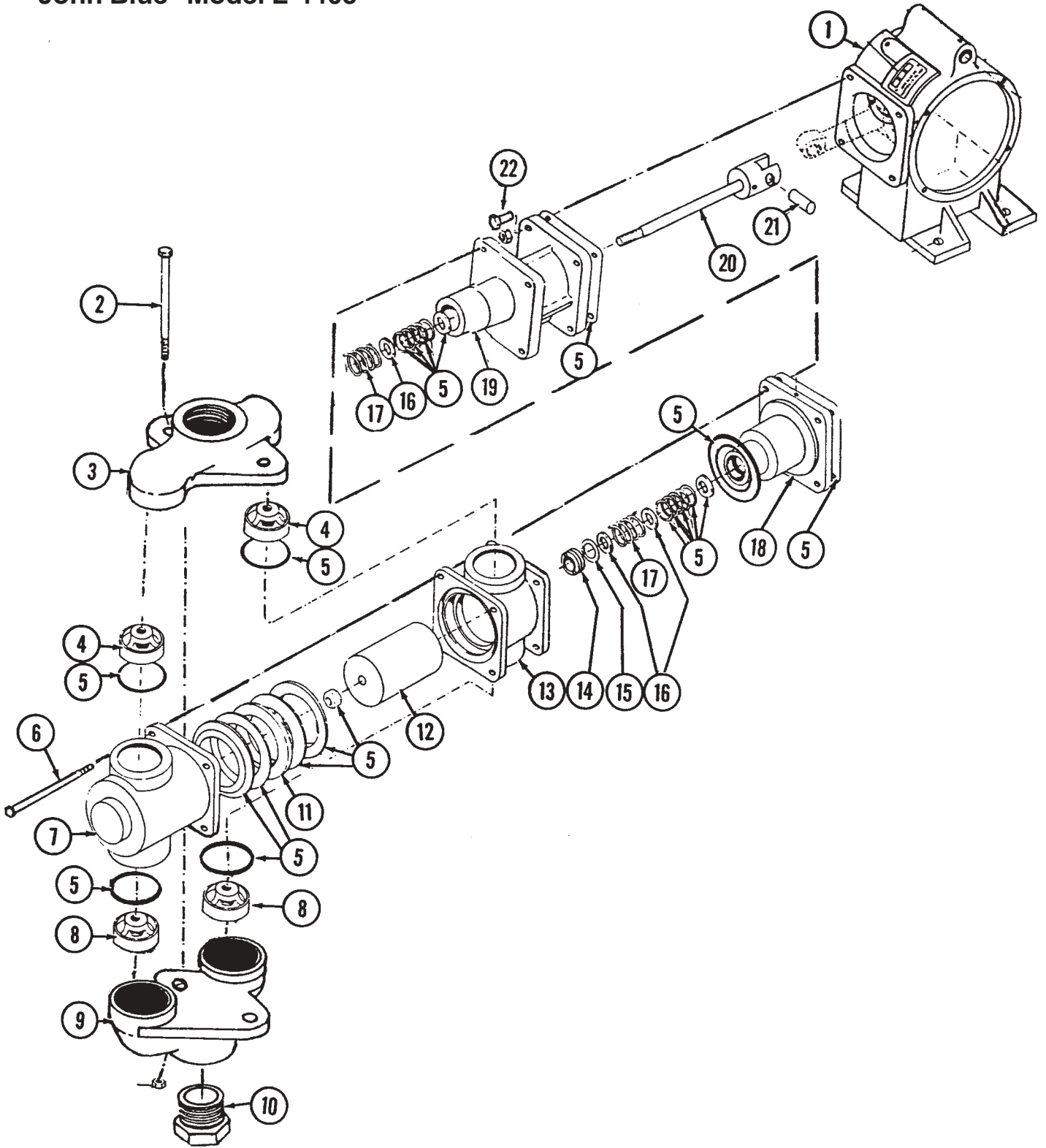

# LIQUID FERTILIZER PISTON PUMP (Cylinder Assembly)

---

ITEM	PART NO.	QTY.	DESCRIPTION
1.		-	See "Liquid Fertilizer Piston Pump (Crankcase Assembly)", Pages P26 And P27
2.	G10686	2	Hex Head Cap Screw, $\frac{3}{8}$ "-16 x 8"
	G10101	2	Hex Nut, $\frac{3}{8}$ "-16
3.	GR1145	1	Discharge Manifold
4.	GR1144	2	Discharge Valve
5.	GR1173	-	Repair Kit, Also Includes Item 6 On "Liquid Fertilizer Piston Pump (Crankcase Assembly)" Pages P26 And P27
6.	G10687	4	Hex Head Cap Screw, $\frac{3}{8}$ "-16 x 5 $\frac{1}{2}$ "
	G10101	4	Hex Nut, $\frac{3}{8}$ "-16
7.	GR1143	1	Outboard Cylinder
8.	GR1142	2	Suction Valve
9.	GR1140	1	Suction Manifold
10.		-	See "Liquid Fertilizer Pump Mount Assembly", Pages P24 And P25
11.	GR1137	1	Flange Packing Washer
12.	GR1136	1	Plunger
13.	GR1135	1	Inboard Cylinder
14.	GR1134	1	Stuffing Box Insert
15.	GR1133	1	Retaining Ring
16.	GR1129	3	Washer
17.	GR1130	2	Packing Spring
18.	GR1132	1	Outboard Stuffing Box
19.	GR1127	1	Crosshead Guide
20.	GR1125	1	Piston Rod
21.	GR1124	1	Pin
22.	G10019	4	Hex Head Cap Screw, $\frac{5}{16}$ "-18 x 1"

# LIQUID FERTILIZER PISTON PUMP FLOW DIVIDER, 4 - 12 Row Machines

JB-L2190-991(PT40)

## John Blue® Flow Divider

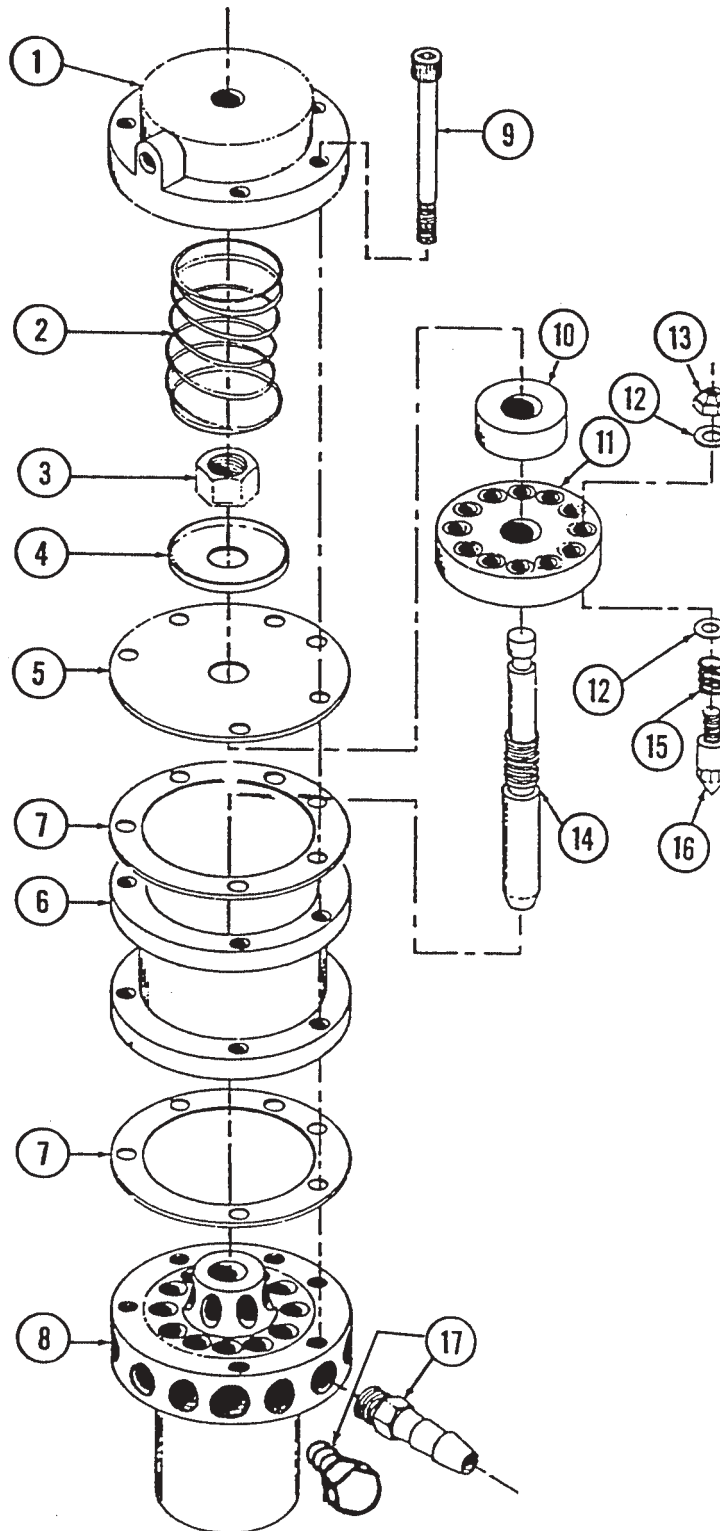

# LIQUID FERTILIZER PISTON PUMP FLOW DIVIDER, 4 - 12 Row Machines

---

ITEM	PART NO.	QTY.	DESCRIPTION
1.	GR1150	1	Cap
2.	GR1151	1	Spring
3.	G10358	1	Hex Nut, 9/16"-18
4.	GR1152	1	Plate
5.	GR1153	1	Diaphragm
6.	GR1154	1	Housing
7.	GR1155	2	Gasket
8.	*	1	Manifold
9.	GR1157	6	Socket Screw, 1/4"
10.	GR1158	1	Lock
11.	*	1	Disk
12.	*	24	Stainless Steel Washer
13.	*	12	Valve Nut
14.	GR1162	1	Plunger
15.	*	12	Spring
16.	*	12	Valve
17.		-	See "Liquid Fertilizer Pump Mount Assembly", Pages P24 And P25
A.	GA6158	1	Liquid Fertilizer Piston Pump Flow Divider Complete, 4 - 6 Row

\* **Factory calibration required. Replacement not recommended. Always be sure timing marks on disk and manifold line up.**

# LIQUID FERTILIZER PISTON PUMP FLOW DIVIDER, 16 Row Machine

JB-L2190-991(TWL45)

## John Blue® Flow Divider

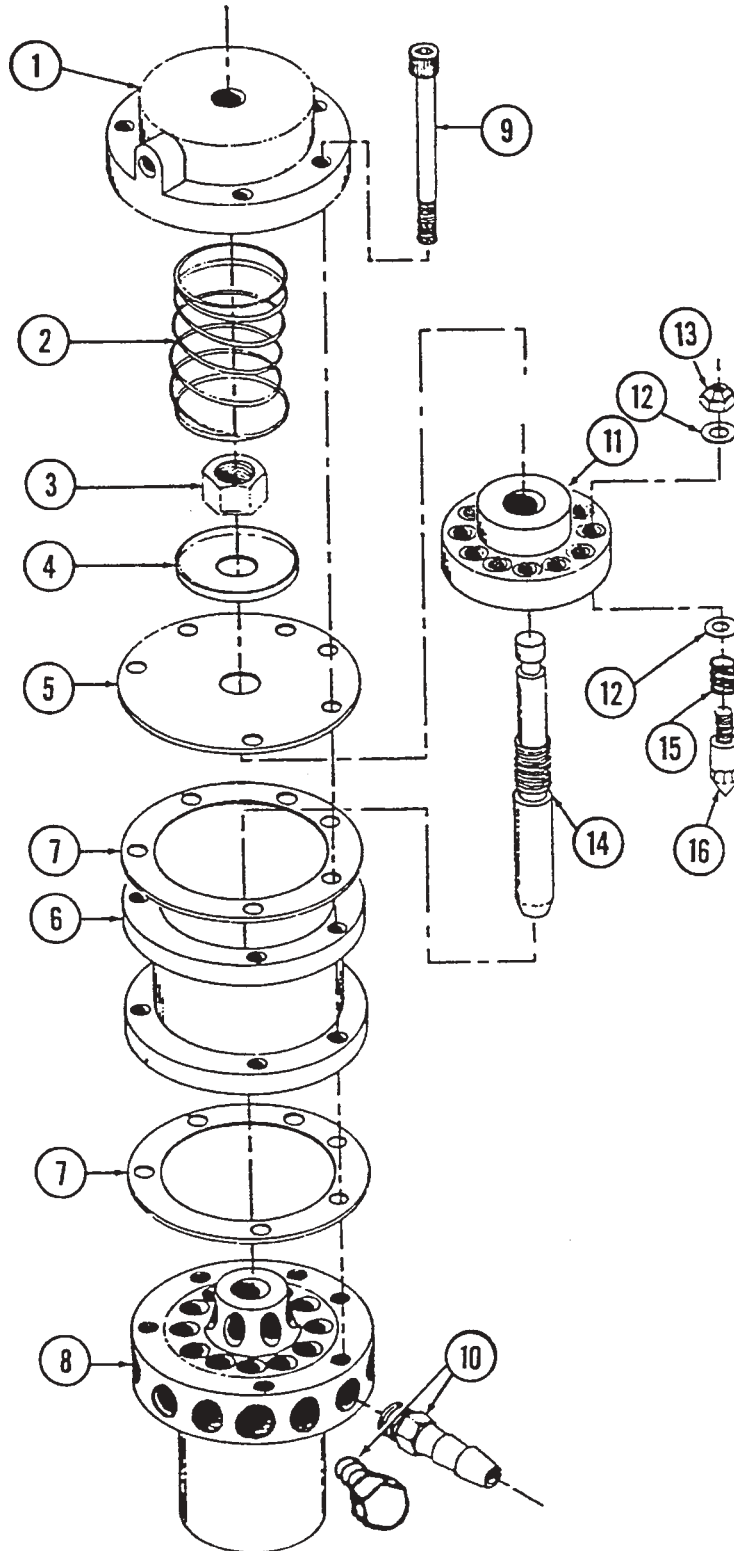

# LIQUID FERTILIZER PISTON PUMP FLOW DIVIDER, 16 Row Machine

---

ITEM	PART NO.	QTY.	DESCRIPTION
1.	GR1188	1	Cap
2.	GR1189	1	Spring
3.	G10358	1	Hex Nut, <sup>9</sup> / <sub>16</sub> "-18
4.	GR1190	1	Plate
5.	GR1191	1	Diaphragm
6.	GR1192	1	Housing
7.	GR1193	2	Gasket
8.	*	1	Manifold
9.	GR1195	6	Socket Screw, <sup>1</sup> / <sub>4</sub> "
10.		-	See "Liquid Fertilizer Pump Mount Assembly", Pages P24 And P25
11.	*	1	Disk
12.	*	24	Stainless Steel Washer
13.	*	12	Valve Nut
14.	GR1199	1	Plunger
15.	*	12	Spring
16.	*	12	Valve
A.	GA6570	1	Liquid Fertilizer Piston Pump Flow Divider Complete, 16 Row

\* Factory calibration required. Replacement not recommended. Always be sure timing marks on disk and manifold line up.

# REAR TELESCOPING HITCH (Toolbar Mounted)

CCU006(CLT18c)

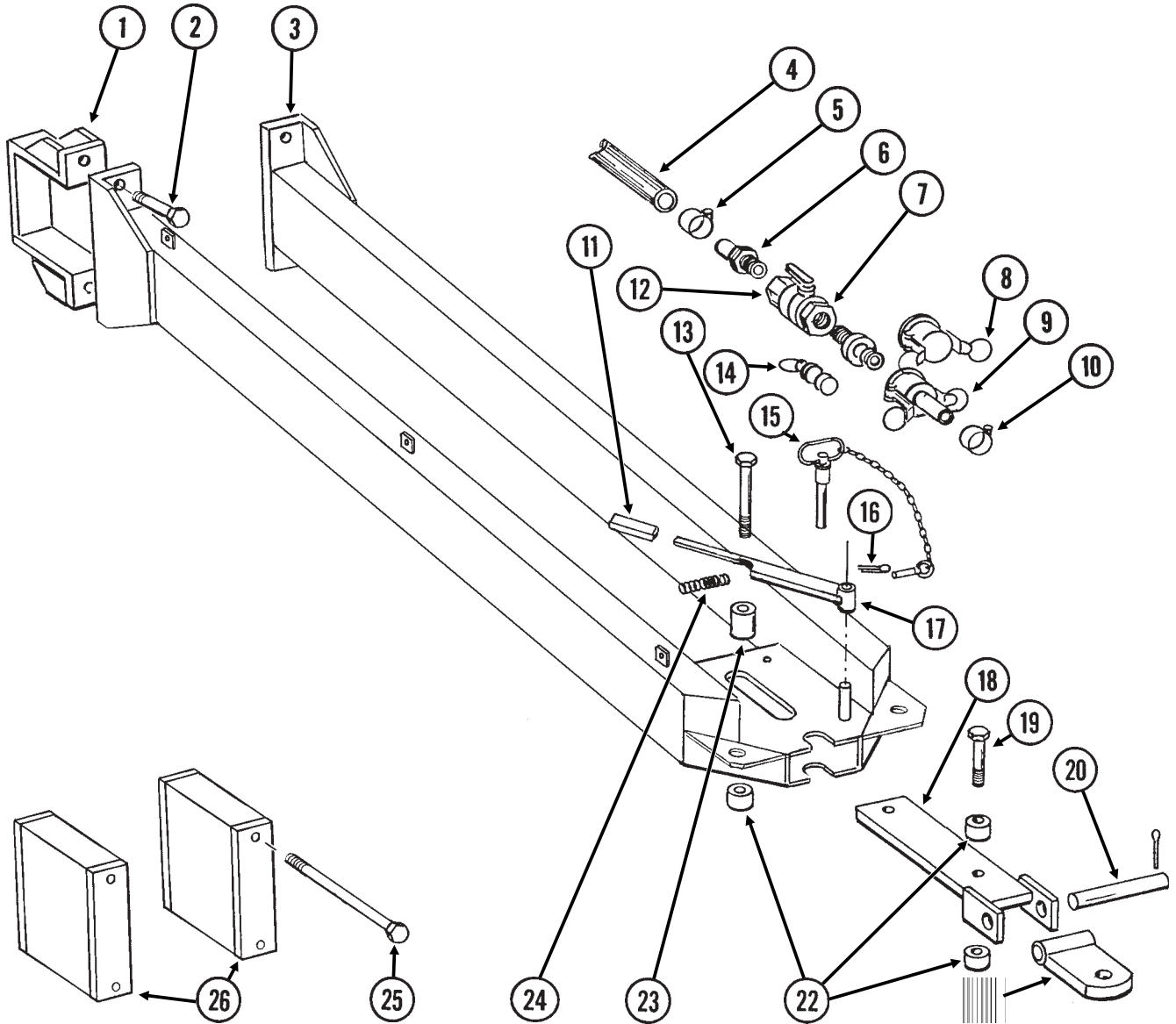

## REAR TELESCOPING HITCH (Toolbar Mounted)

ITEM	PART NO.	QTY.	DESCRIPTION
1.	GA5921	2	Clamp
2.	G10645	4	Hex Head Cap Screw, 1"-8 x 3", Grade 8
	G10118	4	Lock Washer, 1"
	G10698	4	Hex Nut, 1"-8, Grade C
3.	GA6181	1	Hitch
4.	-	-	See "Liquid Fertilizer Pump Mount Assembly", Pages P24 And P25
5.	G10674	2	Hose Clamp, No. 24
6.	G10626	1	Adapter, 1 1/4" NPT To 1 1/4" Barb
7.	GD1514	1	Adapter
8.	GD1515	1	Dust Cap, 1 1/4"
9.	GD1516	1	Adapter
10.	G10672	1	Hose Clamp, No. 28
11.	GD5827	1	Cover
12.	GA4976	1	Ball Valve, Full Port
	GR1015	1	Body O-Ring
	GR1016	1	Stem O-Ring
	GR1017	1	Teflon Seat
	GR1018	1	Ball
	GR1019	1	Handle
13.	G10677	1	Hex Head Cap Screw, 3/4"-10 x 3 1/4"
	G10231	1	Lock Washer, 3/4"
	G10105	1	Hex Nut, 3/4"-10
14.	GD1517	1	Dust Plug
15.	GA6192	1	Clevis Pin W/Lynch Pin And Chain
16.	G10460	1	Cotter Pin, 1/4" x 2"
17.	GA6169	1	Hook W/Grease Fitting
	G10640	1	Grease Fitting, 1/4"-20
18.	GA6170	1	Draw Bar
19.	G10044	1	Hex Head Cap Screw, 3/4"-10 x 4"
	G10231	1	Lock Washer, 3/4"
	G10105	1	Hex Nut, 3/4"-10
20.	GD8839	1	Pin
	G10460	2	Cotter Pin, 1/4" x 2"
21.	GA6177	1	Clevis W/Grease Fitting
	G10640	1	Grease Fitting, 1/4"-20
22.	GD8830	3	Spacer, 3/4"
23.	GD8840	1	Spacer, 1 1/2"
24.	GD5857	1	Spring
25.	G10738	-	Hex Head Cap Screw, 1"-8 x 9", Grade 8
	G10698	-	Lock Nut, 1"-8, Grade C
26.	GA6439	2	Extension, 6"

# REAR TELESCOPING HITCH (Dual Lift Assist Wheel Mounted)

CCU006/CCU012(CLT19)

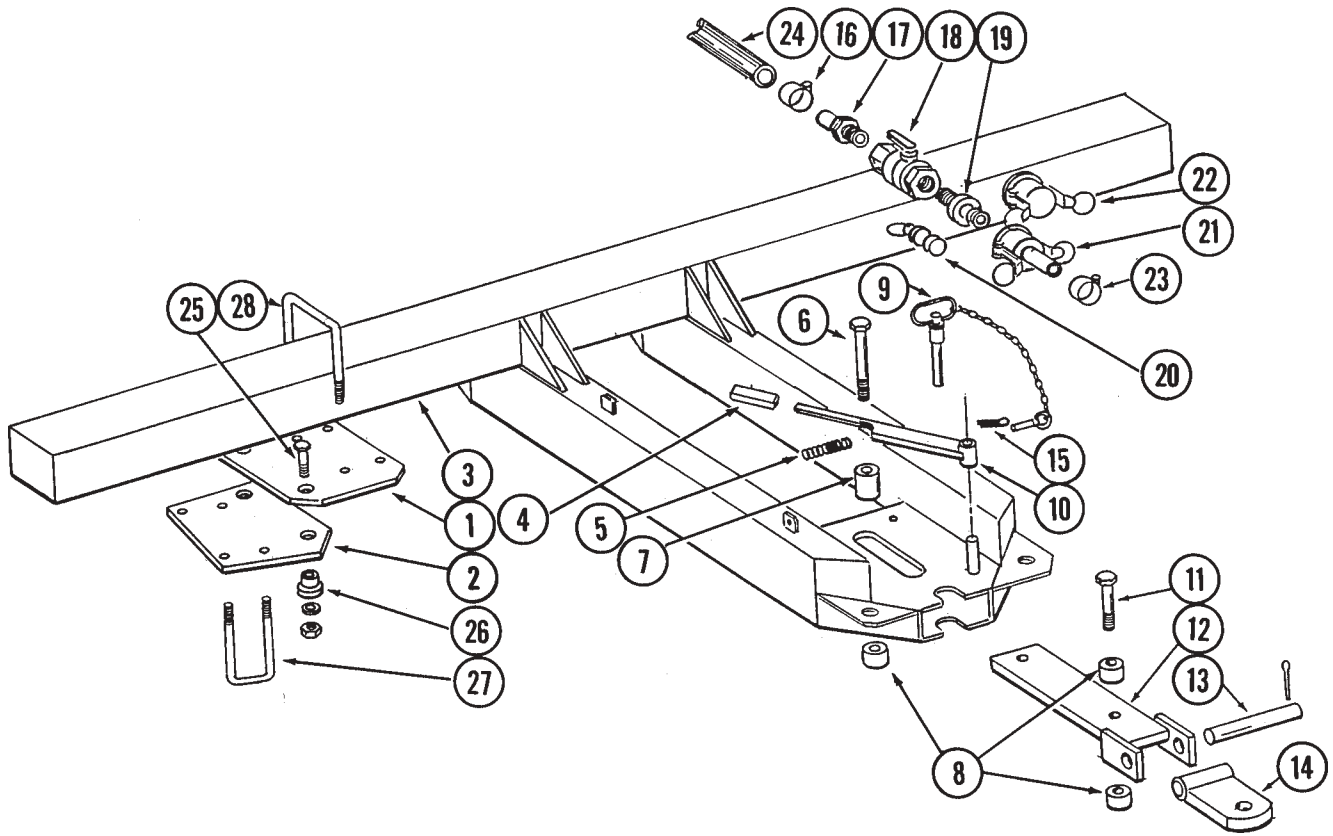

# REAR TELESCOPING HITCH (Dual Lift Assist Wheel Mounted)

ITEM	PART NO.	QTY.	DESCRIPTION
1.	GD9651	2	Plate
2.	GD9652	2	Mounting Plate
3.	GA6778	1	Hitch
4.	GD5827	1	Cover
5.	GD5857	1	Spring
6.	G10677	1	Hex Head Cap Screw, 3/4"-10 x 3 1/4"
	G10231	1	Lock Washer, 3/4"
	G10105	1	Hex Nut, 3/4"-10
7.	GD8840	1	Spacer, 1 1/2"
8.	GD8830	3	Spacer, 3/4"
9.	GA6192	1	Clevis Pin W/Lynch Pin And Chain
10.	GA6169	1	Hook W/Grease Fitting
	G10640	1	Grease Fitting, 1/4"-20
11.	G10044	1	Hex Head Cap Screw, 3/4"-10 x 4"
	G10231	1	Lock Washer, 3/4"
	G10105	1	Hex Nut, 3/4"-10
12.	GA6170	1	Draw Bar
13.	GD8839	1	Pin
	G10460	2	Cotter Pin, 1/4" x 2"
14.	GA6177	1	Clevis W/Grease Fitting
	G10640	1	Grease Fitting, 1/4"-20
15.	G10460	1	Cotter Pin, 1/4" x 2"
16.	G10674	2	Hose Clamp, No. 24
17.	G10626	1	Adapter, 1 1/4" NPT To 1 1/4" Barb
18.	GA4976	1	Ball Valve, Full Port
	GR1015	1	Body O-Ring
	GR1016	1	Stem O-Ring
	GR1017	1	Teflon Seat
	GR1018	1	Ball
	GR1019	1	Handle
19.	GD1514	1	Adapter
20.	GD1517	1	Dust Plug
21.	GD1516	1	Adapter
22.	GD1515	1	Dust Cap, 1 1/4"
23.	G10672	1	Hose Clamp, No. 28
24.		-	See "Liquid Fertilizer Pump Mount Assembly", Pages P24 And P25
25.	G10028	4	Hex Head Cap Screw, 3/4"-10 x 3"
	G10231	4	Lock Washer, 3/4"
	G10105	4	Hex Nut, 3/4"-10
26.	GD9650	4	Floating Mount
27.	GD9663	4	U-Bolt, 6" x 2" x 5/8"-11
	G10230	8	Lock Washer, 5/8"
	G10104	8	Hex Nut, 5/8"-11
28.	GD9662	4	U-Bolt, 4" x 6" x 5/8"-11
	G10230	8	Lock Washer, 5/8"
	G10104	8	Hex Nut, 5/8"-11

# DECALS, REFLECTORS AND TIE STRAPS

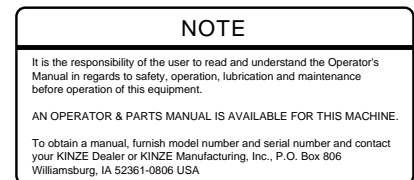
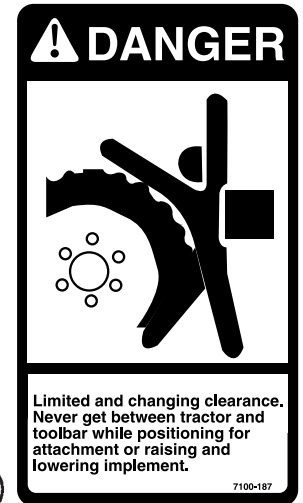
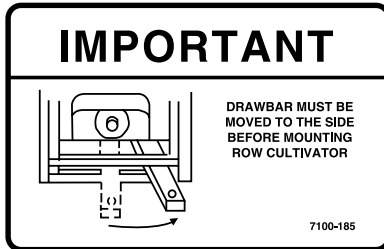
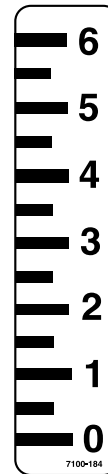
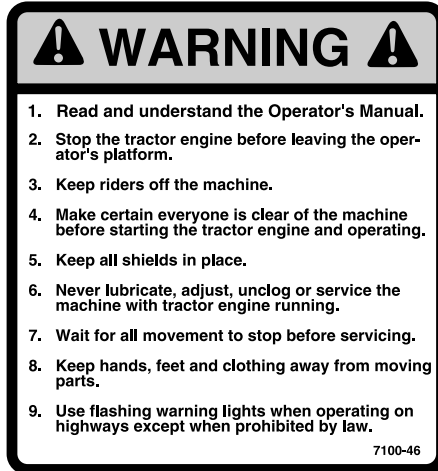
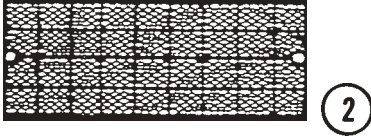

ITEM	PART NO.	QTY.	DESCRIPTION
1.	GD1512	-	Tie Strap, 6" (152mm)
	GD2984	-	Tie Strap, 30" (762mm)
2.	G7200-03	2	Reflector, Red
	G7200-04	2	Reflector, Amber
3.	G7100-46	1	Decal, Warning
4.	G7100-90	1	Decal, Warning
5.	G7100-104	1	Decal, KINZE®, 3" x 12" (76mm x 305mm)
6.	G7100-117	1	Decal, Danger (Folding Machines Only)
7.	G7100-140	2	Decal, Warning (Folding Machines Only)
8.	G7100-183	1	Decal, 1500
9.	G7100-184	1	Decal, Adjustment
10.	G7100-185	1	Decal, Important
11.	G7100-193	1	Decal, Caution (Folding Machines Only)
12.	G7100-187	2	Decal, Danger
13.	G7100-217	-	Decal, Note
14.	GR0155	-	Blue Paint, Aerosol



# NUMERICAL INDEX

Part No.	Page	Part No.	Page	Part No.	Page
A1024	P11	G10048	P3, P4	G10397	P17, P21
A1047	P6, P11	G10049	P6, P15	G10409	P25
A1102	P6	G10053	P13	G10412	P13
A1113	P6	G10054	P27	G10428	P15
A1114	P6	G10061	P6, P17, P19	G10459	P15, P21
A1139	P6	G10064	P3, P5	G10460	P5, P23, P35, P37
A1141	P6	G10068	P23	G10462	P21
A1154	P6	G10081	P11	G10478	P25
A1155	P6	G10082	P15	G10525	P7
A1170	P6	G10087	P11	G10572	P18
A1181	P6	G10093	P21	G10574	P16
A6062	P5	G10101	P9, P13, P19, P27, P29	G10585	P17
A6064	P5	G10102	P3, P11, P13, P15, P21	G10593	P15
A6196	P3	G10104	P3, P6, P11, P12, P16, P21, P23, P25, P27, P37	G10599	P13
A6197	P3	G10105	P35, P37	G10602	P13
A6198	P3	G10106	P18	G10615	P25
A6199	P3	G10107	P6, P15, P17, P18, P21, P23	G10622	P15
A6380	P5	G10108	P3, P4, P6, P15, P17, P27	G10626	P35, P37
A6383	P5	G10109	P13	G10629	P25
A6384	P5	G10110	P3, P5, P13	G10638	P13
A6385	P5	G10111	P3, P4, P6, P11, P15, P16, P17, P21	G10640	P16, P25, P35, P37
A6386	P5	G10112	P5	G10641	P6, P11, P13, P15, P23
A6387	P5	G10113	P11	G10645	P11, P35
A6388	P5	G10118	P35	G10666	P18
A6389	P5	G10152	P21	G10667	P18
A6390	P5	G10194	P5	G10668	P21
A6391	P5	G10203	P13	G10669	P25
A6392	P5	G10205	P16, P25	G10672	P35, P37
A6393	P6	G10209	P3, P5	G10673	P25
A6394	P6	G10210	P9, P19, P27	G10674	P25, P35, P37
A6553	P5	G10211	P13	G10675	P25
A6561	P5	G10217	P13, P21	G10677	P35, P37
A6562	P6	G10224	P13	G10678	P3
A6563	P6	G10228	P3, P11, P15, P21	G10679	P25
G10001	P3, P4, P5, P13, P19	G10229	P3, P5, P13, P19, P27	G10683	P25
G10003	P27	G10230	P3, P6, P11, P12, P13, P16, P21, P23, P25, P37	G10686	P29
G10005	P19, P21	G10231	P11, P23, P35, P37	G10687	P29
G10007	P6, P11, P13	G10232	P21, P23	G10688	P27
G10008	P11, P23	G10234	P11	G10693	P27
G10009	P15, P25	G10235	P25	G10698	P11, P35
G10010	P13	G10266	P7	G10713	P11
G10013	P17, P23	G10269	P7	G10730	P13
G10016	P3, P4, P17	G10289	P7	G10732	P13
G10017	P13	G10292	P25	G10733	P25
G10018	P13	G10305	P19	G10734	P25
G10019	P23, P27, P29	G10318	P18, P27	G10735	P25
G10023	P3, P5	G10322	P5	G10737	P25
G10026	P11, P23	G10341	P16	G10738	P35
G10028	P5, P37	G10358	P31, P33	G10759	P21
G10032	P11	G10389	P25	G2404-08-06	P11
G10036	P6	G10392	P13	G2406-08-06	P6
G10037	P11, P15	G10396	P3	G2500-84	P23
G10038	P6			G2501-08-08	P11
G10039	P15			G2703-08	P6, P11
G10044	P35, P37			G306-08	P6, P11
G10047	P9			G3200-79	P23

# NUMERICAL INDEX

Part No.	Page	Part No.	Page	Part No.	Page
G4200-01	P25	GA5828	P13	GA6564	P21
G4200-03	P25	GA5854	P15	GA6570	P33
G4205-10	P25	GA5921	P11, P35	GA6574	P13
G4300-14	P25	GA6035	P15	GA6595	P8
G4300-15	P25	GA6061	P8	GA6596	P8
G6400-08	P6	GA6063	P5	GA6604	P8
G6500-06	P6	GA6072	P5	GA6605	P8
G6505-06-08	P11	GA6076	P3	GA6699	P7
G7100-104	P38	GA6078	P3, P5	GA6700	P7
G7100-117	P38	GA6079	P21	GA6751	P23
G7100-140	P38	GA6081	P18	GA6756	P21
G7100-183	P38	GA6082	P21	GA6778	P37
G7100-184	P38	GA6084	P21	GA6816	P7
G7100-185	P38	GA6085	P21	GA6817	P7
G7100-187	P38	GA6098	P4	GA6823	P3
G7100-193	P38	GA6129	P15	GA6824	P3
G7100-217	P38	GA6130	P15	GA6831	P7
G7100-46	P38	GA6154	P27	GA6974	P15
G7100-90	P38	GA6158	P31	GA7350	P13
G7200-03	P38	GA6159	P15	GA7861	P11
G7200-04	P38	GA6163	P15	GA7866	P18
G7217X	P15	GA6164	P15	GA7968	P19
GA0241	P23	GA6169	P35, P37	GA7969	P19
GA0251	P23	GA6170	P35, P37	GB0195	P18
GA0252	P23	GA6171	P13, P21	GB0196	P15
GA0262	P25	GA6177	P35, P37	GB0196	P23
GA0270	P11	GA6181	P35	GB0212	P21
GA0547	P23	GA6186	P21	GB0218	P11, P13, P21, P23
GA0895	P11	GA6189	P21	GB0220	P15
GA2014	P18	GA6192	P35, P37	GB0221	P13
GA2068	P13	GA6306	P13	GB0222	P13
GA2148	P11	GA6307	P23	GB0224	P15
GA2558	P11	GA6308	P23	GB0225	P19
GA2559	P23	GA6309	P23	GB0226	P16
GA3893	P25	GA6310	P25	GB0242	P21
GA4122	P7	GA6315	P23	GD0750-08	P18
GA4123	P7	GA6316	P21	GD0829	P25
GA4707	P3	GA6378	P8	GD0831	P23
GA4733	P3, P4	GA6413	P7	GD0844	P11, P23
GA4775	P3	GA6423	P5	GD10442	P13
GA4776	P3	GA6424	P5	GD10443	P13
GA4783	P7	GA6439	P35	GD10973	P19
GA4784	P7	GA6443	P11	GD1114	P3, P6, P21, P25
GA4976	P35, P37	GA6447	P11	GD11234	P19
GA5196	P11	GA6452	P11	GD1166	P11, P23
GA5385	P7	GA6454	P11	GD1512	P38
GA5482A	P9	GA6455	P11	GD1514	P35, P37
GA5482B	P9	GA6473	P11	GD1515	P35, P37
GA5622	P16	GA6527	P25	GD1516	P35, P37
GA5640	P16	GA6528	P6	GD1517	P35, P37
GA5761	P11	GA6551	P5	GD1673	P13
GA5818	P13	GA6554	P13	GD1908	P21
GA5819	P13	GA6555	P13	GD2071	P17
GA5820	P13	GA6556	P13	GD2199	P3, P5
GA5821	P13	GA6557	P13	GD2557	P3, P5, P6
GA5823	P15	GA6558	P12	GD2558	P13, P23

# NUMERICAL INDEX

Part No.	Page	Part No.	Page	Part No.	Page
GD2681	P23	GD8933	P15	GR0970	P7
GD2721	P21	GD8934	P15	GR0987	P8
GD2984	P38	GD8935	P15	GR1015	P35, P37
GD3180-10	P25	GD9041	P5	GR1016	P35, P37
GD4086	P5, P11	GD9119	P5	GR1017	P35, P37
GD5827	P35, P37	GD9125	P17	GR1018	P35, P37
GD5857	P35, P37	GD9126	P17	GR1019	P35, P37
GD6171	P25	GD9170	P11	GR1024	P9
GD6576	P8	GD9179	P11	GR1025	P9
GD7141	P4	GD9208	P11	GR1026	P9
GD7145	P3	GD9247	P4	GR1027	P9
GD7152	P3, P5	GD9259	P5	GR1028	P9
GD7154	P4	GD9268	P6	GR1057	P8
GD7302	P6	GD9274	P17	GR1100	P27
GD7805 ..	P11, P12, P13, P15, P21, P23	GD9275	P13	GR1102	P27
GD7817-01	P21	GD9276	P13	GR1104	P27
GD7817-03	P21	GD9294	P6	GR1105	P27
GD7831	P15, P23	GD9296	P8	GR1106	P27
GD7884	P8	GD9297	P8	GR1107	P27
GD8162	P13	GD9325	P6	GR1108	P27
GD8170	P13	GD9333	P6	GR1109	P27
GD8175	P12	GD9348	P4	GR1110	P27
GD8226	P16	GD9518	P6	GR1111	P27
GD8227	P15	GD9607	P21	GR1112	P27
GD8228	P15	GD9650	P37	GR1114	P27
GD8234	P18	GD9651	P37	GR1116	P27
GD8235	P18	GD9652	P37	GR1118	P27
GD8249	P13	GD9662	P37	GR1119	P27
GD8308	P21	GD9663	P37	GR1120	P27
GD8612	P15	GD9707	P5	GR1122	P27
GD8613	P15	GD9708	P5	GR1123	P27
GD8614	P15	GD9710	P6	GR1124	P29
GD8615	P15	GD9749	P3, P6	GR1125	P29
GD8616	P15	GD9750	P3, P4	GR1127	P29
GD8678	P6	GR0155	P38	GR1129	P29
GD8701	P3, P5	GR0181	P9	GR1130	P29
GD8712	P21	GR0190	P23	GR1132	P29
GD8714	P21	GR0193	P9	GR1133	P29
GD8715	P21	GR0195	P23	GR1134	P29
GD8738	P19	GR0200	P23	GR1135	P29
GD8776	P13	GR0204	P23	GR1136	P29
GD8801	P13	GR0267	P23	GR1137	P29
GD8816	P25	GR0270	P11	GR1140	P29
GD8817	P18	GR0434	P11	GR1142	P29
GD8818	P18	GR0663	P9	GR1143	P29
GD8819	P18	GR0709	P9	GR1144	P29
GD8830	P35, P37	GR0714	P9	GR1145	P29
GD8839	P35, P37	GR0716	P9	GR1146	P25
GD8840	P35, P37	GR0717	P9	GR1147	P27
GD8843	P16	GR0767	P11	GR1148	P27
GD8844	P16	GR0880	P25	GR1150	P31
GD8851	P25	GR0881	P25	GR1151	P31
GD8917	P23	GR0882	P25	GR1152	P31
GD8931	P15	GR0883	P25	GR1153	P31
GD8932	P15	GR0968	P7	GR1154	P31
		GR0969	P7	GR1155	P31

# NUMERICAL INDEX

Part No.	Page	Part No.	Page	Part No.	Page
GR1157 .....	P31				
GR1158 .....	P31				
GR1162 .....	P31				
GR1165 .....	P27				
GR1166 .....	P27				
GR1167 .....	P27				
GR1168 .....	P27				
GR1173 .....	P27				
GR1173 .....	P29				
GR1187 .....	P8				
GR1188 .....	P33				
GR1189 .....	P33				
GR1190 .....	P33				
GR1191 .....	P33				
GR1192 .....	P33				
GR1193 .....	P33				
GR1195 .....	P33				
GR1199 .....	P33				
GR1203 .....	P7				
GR1204 .....	P7				
GR1205 .....	P7				
GR1206 .....	P7				
GR1207 .....	P7				
GR1208 .....	P7				
GR1270 .....	P9				
GR1271 .....	P9				
GR1272 .....	P9				
GR1273 .....	P9				
GR1274 .....	P9				
GR1276 .....	P9				
GR1278 .....	P9				
GR1279 .....	P9				
R1023 .....	P9				